

OPERATION MANUAL

UV INKJET PRINTER

UJV55-320

OPERATION MANUAL

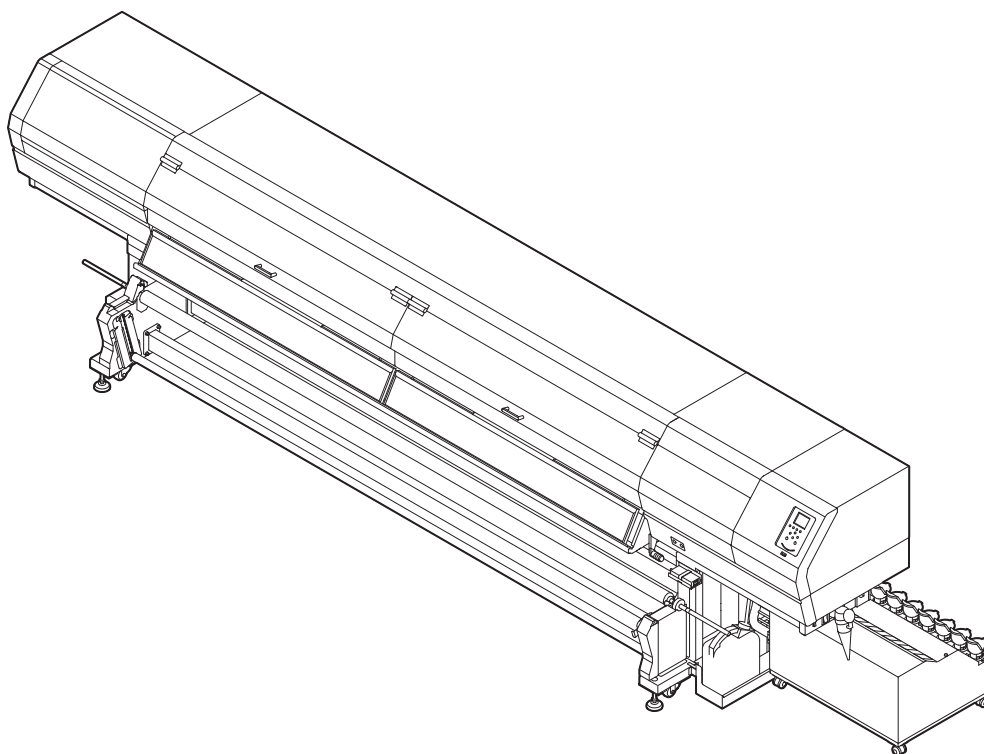

You can also download the latest manual from our website.

MIMAKI ENGINEERING CO., LTD.

<https://mimaki.com/>

D202964-16

Original instructions

Table of contents

CAUTION	v
DISCLAIMER OF WARRANTY	v
Requests	v
FCC Statement (USA)	v
Interference to televisions and radios	v
Foreword	v
About usable ink	v
On This Operation manual	v
Safety Precautions	vi
Symbols	vi
Safety interlock	x
Warning labels	xi

Chapter 1 Before Use

About installing this machine	1-2
Where to Install This Machine	1-2
Working Environmental Temperature.....	1-2
About fixing machine	1-2
Moving This Machine	1-2
Names of Parts and Functions	1-3
Front Side of the Machine	1-3
Rear Side and Right Side of the Machine	1-4
Operation Panel	1-5
Pre-Heater.....	1-7
Media sensor.....	1-7
Carriage.....	1-7
Capping station	1-8
Pinch rollers and Feed rollers.....	1-8
Connecting Cables	1-8
Connecting USB2.0 Interface Cable	1-8
Connecting the LAN cable.....	1-9
Connecting Power Supply Cable.....	1-10
Fill ink in the ink tank and charging.....	1-11
Caution in handling of ink bottles	1-13
Media	1-14
Usable sizes of media	1-14
Caution in handling of medias.....	1-14

Chapter 2 Basic Operations

Workflow.....	2-2
Turning the Power ON/OFF	2-3
Turning the Power ON.....	2-3
Turning the Power OFF.....	2-3
Setting a Media.....	2-4
Adjusting the Head Height and Jam sensor Height.....	2-4
Note for media setting	2-4
Setting a roll media.....	2-5
Use the image quality confirmation LED light to check the print	2-10
Setting a narrow roll media.....	2-12

Setting two narrow roll media (twin rolls)	2-15
Setting media by using the narrow take-up device	2-18
Set the settings of Feeding unit and Take-up unit of Machine Setup to “OFF”	2-18
Lower the tension bar located on the front of the machine to its lowest po- sition to remove the roll shaft	2-18
Set media by using the narrow take-up device	2-18
Set media by using the narrow take-up device (twin rolls)	2-19
Setting leaf media	2-20
Removing the taken-up media	2-21
Changing the printing origin	2-21
Preparing for the Heaters	2-22
Changing the Temperature Settings for the Heaters	2-22
Test Printing	2-22
Test Printing	2-23
Head Cleaning	2-23
About head cleaning	2-23
Perform head cleaning depending on the test printing result	2-23
Setting of Media Correction	2-24
Setting of Media Correction	2-24
Correct the ink drop position for bidirectional printing	2-25
Printing Data	2-26
Starting a Printing Operation	2-26
Stopping a Printing Operation	2-26
Deleting Received Data (Data Clear)	2-26

Chapter 3 Extended Functions

About Setup MENU	3-2
Setup MENU table	3-3
Register the optimal print conditions to match the use	3-4
Setting of Media Correction	3-5
If the Positions of Dots Shift...	3-6
Setting the Heater	3-6
Setting of Logical Seek	3-7
Setting of Overprint	3-7
Setting of Left and Right Margins	3-8
Setting of UV mode	3-8
Setting of Refresh	3-9
Setting of Vacuum Fan	3-9
Setting of Print Speed	3-10
Setting of MAPS4	3-10
Setting Auto Cleaning	3-10
Setting Interval wiping	3-11
Setting of LT mode	3-11
About Machine Setup MENU	3-12
Machine Setup MENU table	3-13
Setting a AUTO Power-off	3-14
Setting Feeding unit	3-14
Setting Take-up unit	3-14
Setting the Display of Media Remain	3-15
Setting Time	3-15

Setting Unit (Temperature/ Length).....	3-15
Setting a Key Buzzer.....	3-15
Setting the Display of Media Detection	3-16
Setting the CONFIRM. FEED.....	3-16
Set the network	3-16
Setting event mail function	3-17
Setting the Setting Lock function.....	3-21
Initializing the Settings.....	3-21
About Nozzle Check MENU.....	3-22
Nozzle Check MENU table.....	3-22
Printing Check Flow	3-23
Printing Operations at “Nozzle Missing” Judgment and Error Occurrence 3-23	
Setting the Printing Check.....	3-24
Setting the Auto Nozzle Recovery	3-24
Setting the Judgement Condition	3-24
About Information MENU.....	3-25
Information MENU table	3-25
Displaying the Information.....	3-26
Displaying the Information of this machine.....	3-26
Setting a Language.....	3-27

Chapter 4 Maintenance

Maintenance	4-2
Precautions for Maintenance.....	4-2
About Cleaning Solution.....	4-2
Ink Maintenance	4-2
Cleaning the Exterior Surfaces.....	4-2
Cleaning the Platen	4-2
Cleaning of pre-heater cover and Image quality confirmation LED Light.....	4-3
Cleaning the Media Sensor	4-4
Cleaning the Media Press	4-4
About Maintenance MENU	4-5
Maintenance MENUs at-a-glance	4-6
Maintaining the Capping Station.....	4-7
Cleaning the Wiper and Cap	4-7
Washing the Ink Discharge Passage	4-9
When the Machine Is Not Used for a Long Time (Custody Wash)...	4-10
Cleaning the Ink Head and the Area around It	4-12
When nozzle missing Cannot Be Solved.....	4-13
Washing the Head Nozzle.....	4-13
Nozzle Recovery Function	4-14
Automatic Maintenance Function	4-16
Setting the Refreshing level	4-16
Setting the Cleaning level.....	4-17
Setting the Cleaning level for White ink.....	4-17
About white ink circulation function	4-17
Discarding waste ink.....	4-18
For waste ink remaining management	4-19
Adjust the waste ink.....	4-19
Replacing consumables.....	4-20

Replacing the wiper	4-20
Replacing the Mist Fan Filter (H fan filter)	4-20
Replace the ink tank and ink fillter	4-22
Tank Calibration	4-23
Replacing the cap absorber	4-25
Refilling antifreeze mixed water	4-26
Refill antifreeze mixed water	4-27

Chapter 5 Troubleshooting

Troubleshooting	5-2
Power does not turn on	5-2
The machine does not start printing	5-2
Media get jammed / media is soiled	5-3
Image quality is poor	5-3
Nozzle is clogged	5-3
Ink tank warning appears	5-4
When the ink leakage occurs	5-4
If an error related to the Sub Tank occurs (Error 618 to 61b)	5-4
If nozzle missing due to color mixture of ink or aeration	5-4
When media heaves up at feeding	5-7
Warning / Error Messages	5-8
Warning messages	5-8
Error messages	5-13

Chapter 6 Appendix

Specifications	6-2
Machine specifications	6-2
Ink specifications	6-3
Supply item list	6-4
Setting orders of ink tanks	6-5
Sheet for inquiry	6-6

CAUTION

DISCLAIMER OF WARRANTY

THIS LIMITED WARRANTY OF MIMAKI SHALL BE THE SOLE AND EXCLUSIVE WARRANTY AND IS IN LIEU OF ALL OTHER WARRANTIES, EXPRESS OR IMPLIED, INCLUDING, BUT NOT LIMITED TO, ANY IMPLIED WARRANTY OF MERCHANTABILITY OR FITNESS, AND MIMAKI NEITHER ASSUMES NOR AUTHORIZES DEALER TO ASSUME FOR IT ANY OTHER OBLIGATION OR LIABILITY OR MAKE ANY OTHER WARRANTY OR MAKE ANY OTHER WARRANTY IN CONNECTION WITH ANY PRODUCT WITHOUT MIMAKI'S PRIOR WRITTEN CONSENT.

IN NO EVENT SHALL MIMAKI BE LIABLE FOR SPECIAL, INCIDENTAL OR CONSEQUENTIAL DAMAGES OR FOR LOSS OF PROFITS OF DEALER OR CUSTOMERS OF ANY PRODUCT.

Requests

- This Operation manual has been carefully prepared for your easy understanding.
However, please do not hesitate to contact a distributor in your district or our office if you have any inquiry.
- Description contained in this Operation manual are subject to change without notice for improvement.

FCC Statement (USA)

This equipment has been tested and found to comply with the limits for a Class A digital device, pursuant to Part 15 of the FCC Rules. These limits are designed to provide reasonable protection against harmful interference when the equipment is operated in a commercial environment.

This equipment generates, uses and can radiate radio frequency energy and, if not installed and used in accordance with the operation manual, may cause harmful interference to radio communications.

Operation of this equipment in a residential area is likely to cause harmful interference in which cause the user will be required to correct the interference at his own expense.



- In the case where MIMAKI-recommended cable is not used for connection of this machine, limits provided by FCC rules can be exceeded. To prevent this, use of MIMAKI-recommended cable is essential for the connection of this machine.

Interference to televisions and radios

The product described in this manual generates high frequency when operating.

The product can interfere with radios and televisions if set up or commissioned under improper conditions.

The product is not guaranteed against any damage to specific-purpose radio and televisions.

The product's interference with your radio or television will be checked by turning on/off the power button of the product.

In the event that the product is the cause of interference, try to eliminate it by taking one of the following corrective measures or taking some of them in combination.

- Change the orientation of the antenna of the television set or radio to find a position without reception difficulty.
- Separate the television set or radio from this product.
- Plug the power cord of this product into an outlet which is isolated from power circuits connected to the television set or radio.

Foreword

Congratulations on your purchase of MIMAKI color ink jet printer "UJV55-320".

"UJV55-320" is a color inkjet printer that can print with UV ink realizing high speed and high image quality.

About usable ink

Usable ink for this machine is LUS120 ink (four-color model).

- 4-colors version : Each of Cyan, Magenta, Yellow and Black color ink cartridge are useable.
- 6-colors + White : Each of Cyan, Magenta, Yellow, Black, Light cyan, Light magenta and White color ink cartridge are useable.

On This Operation manual

- This Operation manual is describing the operations and maintenance of "Color inkjet printer UJV55-320" (called as this machine hereafter)
- Read this Operation manual carefully and understand them thoroughly to use.
- It is also necessary to keep this Operation manual on hand.
- This Operation manual has been carefully prepared for your easy understanding, however, please do not hesitate to contact a distributor in your district or our office if you have any inquiry.
- Descriptions contained in this Operation manual are subject to change without any notice for improvement.
- You can also download the latest manual from our website.

Reproduction of this manual is strictly prohibited.
All Rights Reserved. Copyright
© 2016 MIMAKI ENGINEERING Co., Ltd.











Safety Precautions

Symbols

Symbols are used in this Operation Manual for safe operation and for prevention of damage to the machine. The indicated sign is different depending on the content of caution.



Symbols and their meanings are given below. Please follow these instructions as you read this manual.

Examples of symbols

Meaning	
	Failure to observe the instructions given with this symbol can result in death or serious injuries to personnel. Be sure to read it carefully and use it properly.
	Failure to observe the instructions given with this symbol can result in injuries to personnel or damage to property.
	Important notes in use of this machine are given with this symbol. Understand the notes thoroughly to operate the machine properly.
	Useful information is given with this symbol. Refer to the information to operate the machine properly.
	Indicates the reference page for related contents.
	The symbol "  " indicates that the instructions must be observed as strictly as the CAUTION instructions (including DANGER and WARNING instructions). A sign representing a precaution (the sign shown at left warns of hazardous voltage) is shown in the triangle.
	The symbol "  " indicates that the action shown is prohibited. A sign representing a prohibited action (the sign shown at left prohibits disassembly) is shown in or around the circle.
	The symbol "  " indicates that the action shown must be taken without fail or the instructions must be observed without fail. A sign representing a particular instruction (the sign shown at left instructs to unplug the cable from the wall outlet) is shown in the circle.

Warning for Use

WARNING

-  • Do not use the machine in a poorly ventilated room or a closed room.
- Avoid locating the machine in a damp environment. Do not splash water onto the machine. Use in such an environment can give rise to fire, electric shocks or breakdown of the machine.
- Use it with the displayed power supply specifications. The power-supply voltage of this machine shall be single-phase 200 to 240 Vac 15A and less. (You cannot use this machine in the 100V system.)
- Use of the machine under an abnormal condition where it produces smoke or strange smell can result in fire or electric shocks. If such an abnormality is found, be sure to turn off the power button immediately and unplug the cable from the wall outlet. Check first that the machine no longer produces smoke, and then contact your distributor or a sales office of MIMAKI for repair. Never repair your machine and ink bottle by yourself since it is very dangerous for you to do so.
- Never disassemble or remodel the main unit of the machine or the ink bottle. Disassembly or remodeling can result in an electric shock or breakdown of the machine.
- Take care that no dust or dirt sticks to platen. Dust and dirt sticking heaters can cause fire.
- In case of ink leakage, please turn off the main power, unplug the power cable and contact your local distributor, our sales office or our call center.
- Do not place your fingers or other parts of body close to dangerous moving parts.
- If ink leaks, turn off the main power switch, disconnect the power plug, and contact your local distributor, our sales office, or call center.
-  • Keep children away from this machine.
-  • The main power circuit breaker should be set ON only by personnel with sufficient knowledge about operations of this unit.
- Do not touch the LED UV unit on or right after the lamp off with bare hands to avoid from burn injury.

Handling of LED UV unit

-  • Do not use the LED UV in an ambience with a possibility of catching fire (gasoline, combustible gas spray, thinner, lacquer, powder dust, etc.). In addition, do not put paper or cloth near or on the LED UV, or it may cause fire.or it may cause electrical shock.
- Never look at the LED UV being lit with your naked eyes,or it may cause pain in your eyes or visual impairment.Be sure to wear safety glasses.
- Do not apply ultraviolet (UV) light directly to your skin,or it may cause irritation on your skin.
- It is recommended to replace the LED UV unit within the rated life.

Disposition of this machine

-  • When discarding this machine, request the treatment of it for an industrial waste disposal contractor.
- Treat it properly in compliance with regulation in the local area.

Handling the Anti-freezing liquid

 **WARNING**



- Use the exclusive Anti-freezing liquid by Mimaki, or the LED UV cooling device may be damaged.
- If the Anti-freezing liquid or mixed soft water with anti-freezing liquid gets on the skin or clothes, immediately wash it off with soap. If you get the Anti-freezing liquid or mixed soft water with anti-freezing liquid in your eyes, immediately wash your eyes with a lot of clean water. Then, consult a doctor as soon as possible. If high temperature Anti-freezing liquid or mixed soft water with anti-freezing liquid gets on the skin, immediately wash it off with soap and cool with iced water. Then, consult a doctor as soon as possible.
- Before using the Anti-freezing liquid, be sure to read the Safety Data Sheet (SDS).
- If you swallowed the Anti-freezing liquid or mixed soft water with antifreezing liquid accidentally, try to get to vomit, and then consult a doctor as soon as possible.
- When unused the Anti-freezing liquid or used mixed soft water with anti-freezing liquid should discard as followings,
- Incinerating the fluid which is absorbed to the sawdust or waste cloth.
- Entrust them to an industrial waste disposal contractor, clarifying their contents.
- Avoid ignition such as static electricity and impact spark.



- Be sure to wear the included safety glasses and gloves for handling the Anti-freezing liquid.



- loves are consumables. Use commercially-available ones if you lose or use up the supplied gloves.

Precautions in Use

 **CAUTION**

Handling of the power cable



- Use a power cable attached to this unit.
- Take care not to damage, break or work on the power cable. If a heavy matter is placed on the power cable, heated or drawn, the power cable can break to cause fire or electric shocks.
- Connect to a socket-outlet with determinate polarity.

Power supply



- Leave the breaker turned ON.
- Do not turn off the main power switch on the right side of this machine.

Heater



- Do not spill liquid on the pre-heater as this may cause failure of the heater or firing.
- Do not touch pre-heater heaters with bare hand while it is hot; otherwise, you can get burned.

Note on maintenance



- When cleaning the ink tank unit or the heads, make sure to wear the attached gloves.



- When handling ink and cleaning solution, pay close attention to ventilation and be sure to wear the included safety glasses and gloves.
- Gloves are consumables. Use commercially-available ones if you lose or use up the supplied gloves.

Handling of ink / cleaning solution



- Before using ink and cleaning solution, be sure to read the Safety Data Sheet (SDS).
- If you get ink or cleaning solution in your eyes, immediately wash your eyes with a lot of clean water for at least 15 minutes. In doing so, also wash eyes to rinse ink away completely. Then, consult a doctor as soon as possible.
- If someone swallows ink or cleaning solution by mistake, keep him or her quiet and take them to see a doctor immediately. Do not let allow the person to swallow the vomit. Then contact the emergency number written in SDS.
- If you inhale a great deal of vapor and feel ill, immediately move to a location with plenty of fresh air, and keep yourself warm and quiet. Consult a doctor as soon as possible.
- A part of the ingredients (photo polymerization initiator) has toxicity against aquatic organisms. Please prevent leakage flow to natural water systems (river, etc.) and domestic sewages (toilet, road, etc.)

Grounding work



- This unit requires grounding work to prevent electrical shock.
- Carry out the grounding work.

Wearing protective devices



- When cleaning the suction nozzle, which may scatter ink, be sure to wear the included safety glasses and gloves, or ink and washing liquid might enter your eyes or ink and washing liquid put on your hands might make your hands rough.



CAUTION

Handling the Anti-freezing liquid Power supply

- Be sure to store the Anti-freezing liquid in a cold and dark place.
- Store the Anti-freezing liquid in a place that is out of the reach of children.

About UV light

- A little UV light leaks from the LED UV unit. UV light applied to your skin might cause inflammation and/or skin cancer. Though weak UV light might cause no inflammation, repeated exposure to it may lead to chronic disorders. Avoid applying UV light to your skin and eyes.
- The floor may be discolored because of UV light leakage, please install the printer unit on the mat for shielding the light.

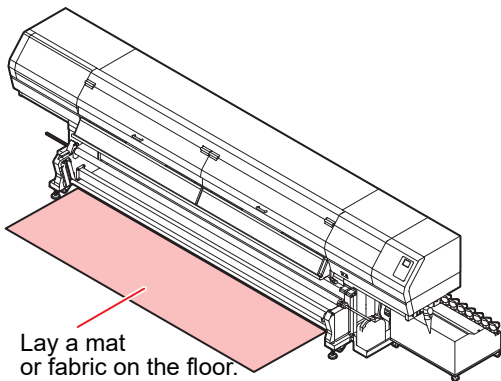

- Possible damage to your eyes due to ultraviolet is acute disorder (feeling like something is in your eye, pain and flow of tears) and chronic disorder (cataract etc.). When using this machine, take protective measures such as gloves, long-sleeve cloth, light-resistant mask, attached UV goggles, etc.

About hot parts

- The LED UV unit becomes very hot. When carrying out maintenance, wait until the temperature has been sufficiently lowered after the lamp is turned OFF.
- Some parts outside the unit will have a very high temperature. A high-temperature caution label is placed on such parts. Do not touch the parts with the caution label placed and their vicinity, or burn injury may occur.
- When it is unavoidable to touch hot parts, be sure to wear heat-insulating gloves to protect your hands.

CAUTION

Notes on LED UV unit

- When handling the LED UV or the silica glass on the bottom of the irradiation device, be sure to wear the gloves attached and never touch them with bare hands, or the UV ink curing level is significantly lowered. If the LED UV or silica glass is contaminated, wipe it with clean gauze moistened with alcohol. (Do not use alcohol for cleaning the exterior cover, or the paint will peel off.)
- The LED UV performance and service life are significantly affected by the UV irradiation and UV power supply units used. Never use those UV devices other than those recommended by Mimaki. We would take no responsibility for any troubles caused through the use of a UV devices not recommended by Mimaki.

About cleaning

- After using the unit long time, foreign materials and dust may be gathered on the conductive and insulating parts, causing electric leakage. Periodically clean such parts.
- For cleaning, do not use compressed air because it scatters foreign materials and dust, which may cause malfunctions when put inside the conductive parts. Be sure to use vacuum cleaner for cleaning of foreign materials and dust.
- Do not use the unit in a place where there is a possibility of being wet, or electrical leakage may occur.
- Electrical leakage, if it should occur, may lead to electrical shock of personnel or fire.
- In order to prevent accidents from occurring, be sure to carry out periodic inspections and replacement of time-change components.

About firing and smoking



- Touching hot parts such as the LED UV unit with combustible materials may cause firing and/or smoking. Leaving combustible materials under the UV LED unit for a couple minutes may also cause firing and/or smoking.
- After the unit is used long time, foreign materials or dust gathered on the stabilizer or other parts may cause electrical leakage or insulation deterioration may cause firing and/or smoking. Periodically clean the parts and measure the insulation resistance, replacing deteriorated parts, if any.
- After the unit is used long time, screws, etc. on the conductive parts may be loosened, causing firing and/or smoking. Periodically tighten such screws.
- Because this unit is not of explosion proof type, do not use it in an ambience with hazardous materials, or a possibility of explosion may arise.
- If abnormalities of the unit such as a strange odor, a smoking or a spark burn are found, turn the power off and call Mimaki immediately.

CAUTIONS and NOTES

 Warning
<p>Handling of ink bottles</p> <ul style="list-style-type: none"> • Use the UJV55-320 genuine ink. Remember that the user shall be filled for a repair to correct any damage resulting from the use of ink other than the exclusive type. • The machine does not operate with any ink other than the UJV55-320 genuine ink. • Do not use the UJV55-320 genuine ink with other printers, as doing so may cause damage to such machines. • Never refill the ink bottle with ink. Refilled ink bottle can cause a trouble. Remember that MIMAKI assumes no responsibility for any damage caused by the use of the ink bottle replenished with ink. • If the ink bottle is moved from a cold place to a warm place, leave it in the room temperature for three hours or more before using it. • Open the ink bottle just before using it. If it is opened and left for an extended period of time, normal printing performance of the machine may not be ensured. • Make sure to store ink bottles in a cool and dark place. • Store ink bottles and waste ink tank in a place that is out of the reach of children. • Be sure to thoroughly consume the ink in the ink bottle, once it is opened, within three months. If an extended period of time has passed away after opening the ink bottle, printing quality would be poor. • Neither pound the ink bottle nor shake it violently, as doing so can cause leakage of ink. • Do not touch or stain the contacts of the IC chip, as doing so may cause damage to the print circuit board. • Waste ink is equivalent to waste oil of industrial waste. Request an industrial waste disposal company for disposal of waste ink. • Do not discard to natural water systems (river, lake, etc.) and domestic sewages (toilet, washstand, road, etc.).
<p>Front cover and lever</p> <ul style="list-style-type: none"> • Never open the front cover or raise the lever during printing.
<p>Handling of media</p> <ul style="list-style-type: none"> • Use media recommended by MIMAKI to ensure reliable, high-quality printing. • Set the temperature of the Pre-heater according to the type and characteristics of the media used. Automatic temperature setting can be made on the operation panel by setting the profile on the dedicated RIP. For setting on the RIP, refer to the instruction manual for your RIP. • Pay attention to the expansion and contraction of the media. Do not use media immediately after unpacking. The media can be affected by the room temperature and humidity, and thus it may expand and contract. The media have to be left in the atmosphere in which they are to be used for 30 minutes or more after unpacked. • Do not use curled media. The use of curled media can not only cause a media jam but also affect print quality. Straighten the sheet of media, if significantly curled, before using it for printing. If a regular-sized coated sheet of media is rolled and stored, the coated side has to face outside. • Do not leave the media with the heater ON for a long time.

 Warning
<p>Protection of media from dust</p> <ul style="list-style-type: none"> • Store media in a bag. Wiping off dust accumulated on media will adversely affect the media due to static electricity. • When leaving the workshop after the working hours, do not leave any media on the roll hanger. If any media is left on the roll hanger, it can get dusty.
<p>Notes on maintenance</p> <ul style="list-style-type: none"> • It is strongly recommended to use the machine in a room that is not dusty. • Keep the front cover closed even when the machine is not printing. If not, dust can accumulate on the nozzles in the heads. • Dust in the heads can also cause drops of ink to fall suddenly down on the media during printing. In such a case, be sure to clean up the heads. • When cleaning the ink-station or the heads, make sure to wear the attached gloves. • Perform wiping (removal of dust and paper powder) of the capping station and wiper frequently.
<p>Periodic replacement parts</p> <ul style="list-style-type: none"> • Some parts of this machine must be replaced with a new one periodically by service personnel. Be sure to make a contract with your distributor or dealer for After sale service to ensure a long life of your machine.
<p>Disposition of this machine</p> <ul style="list-style-type: none"> • When discarding this machine, request the treatment of it for an industrial waste disposal contractor. • Treat it properly in compliance with regulation in the local area.

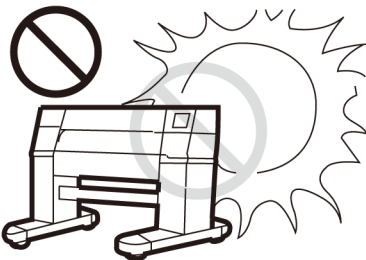
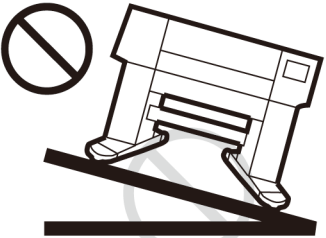
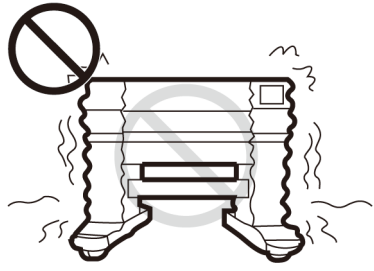
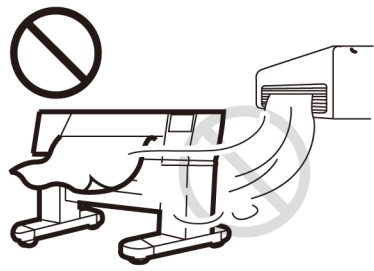
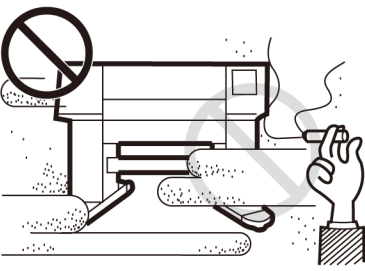
Cautions on Installation

 CAUTION		
A place exposed to direct sunlight	On an inclined surface	A place that vibrates
		
A place exposed to direct air flow from an air conditioner or the like.	Around a place where fire is used	A place where temperature or humidity varies significantly
		 <ul style="list-style-type: none"> • Use the machine under the following environmental conditions: • Operating environment: 20 to 30 °C (68 to 86 °F) 35 to 65 % (Rh)

Safety interlock



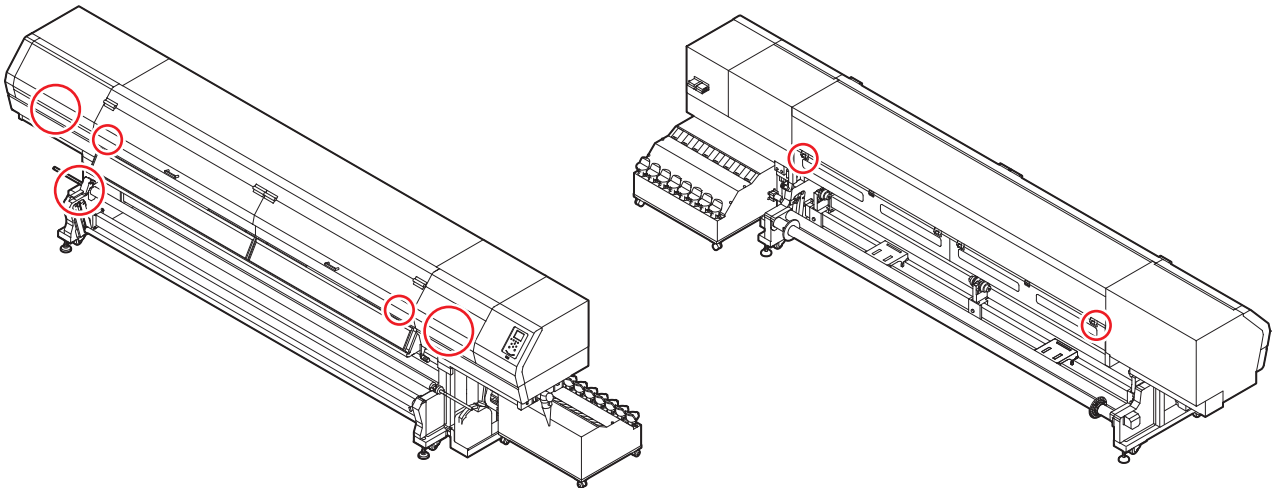



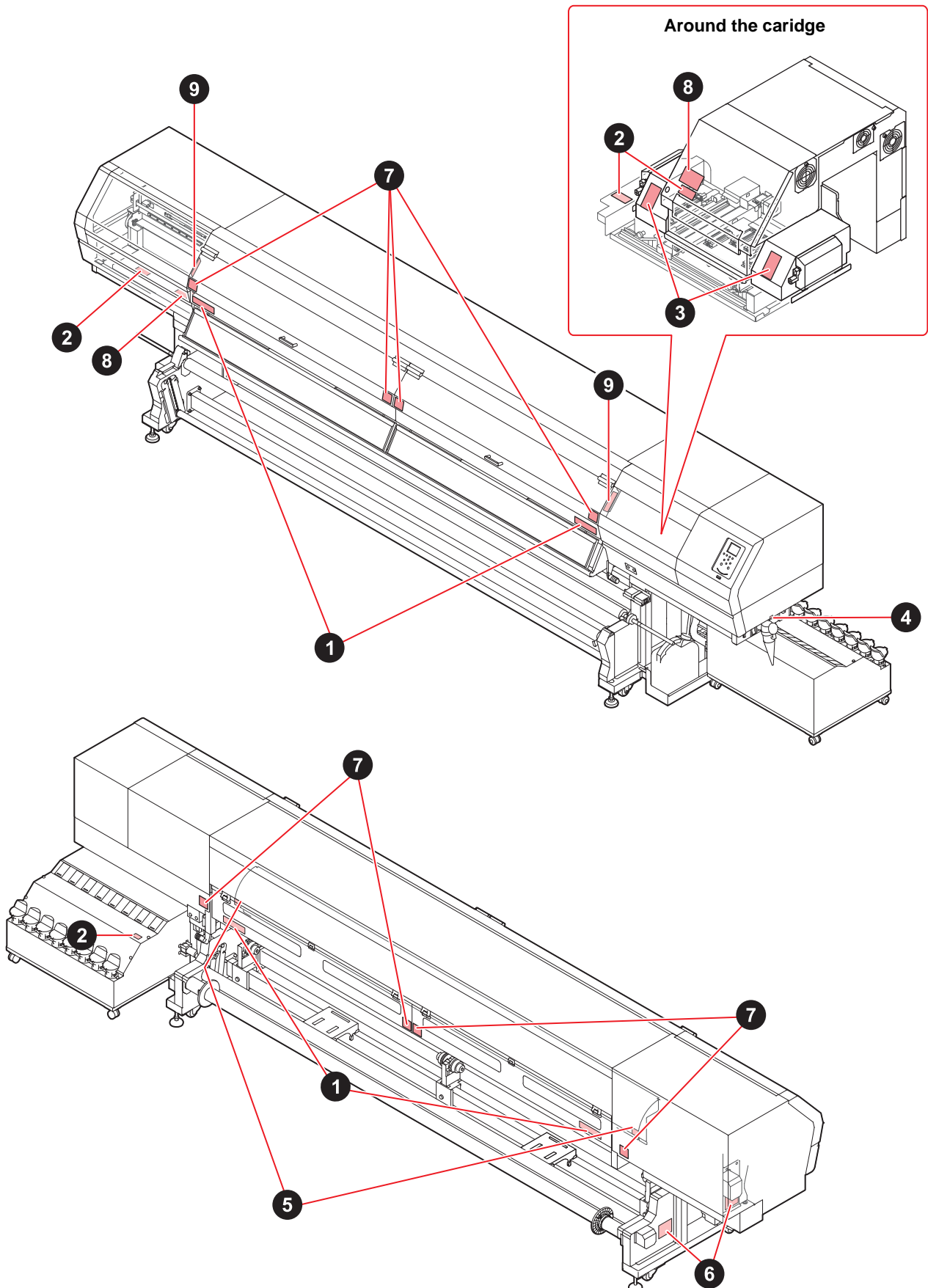

This machine is equipped with interlocks to terminate the operation for your safety when the cover opens during printing etc. (red circle parts in the figure below).



Warning labels

Warning labels are stuck on the machine. Be sure to fully understand the warning given on the labels. If a warning label is illegible due to stains or has come off, purchase a new one from a distributor or our sales office.

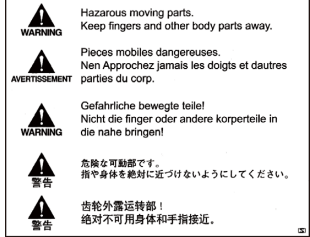

No.	Reorder	Label	No.	Reorder	
1	M905811				
2	M903330		7	M910931	
3	M905980		8	M912522	
4	M907935		9	M912523	
5	M903239				
6	M903404				

Chapter 1

Before Use



This chapter

describes the items required to understand before use, such as the name of each part of the machine or the installation procedures.

About installing this machine	1-2	Connecting Cables	1-8
Where to Install This Machine	1-2	Connecting USB2.0 Interface Cable	1-8
Working Environmental Temperature	1-2	Connecting the LAN cable	1-9
About fixing machine	1-2	Connecting Power Supply Cable	1-10
Moving This Machine	1-2	Fill ink in the ink tank and charging	1-11
Names of Parts and Functions	1-3	Caution in handling of ink bottles	1-13
Front Side of the Machine	1-3	Media	1-14
Rear Side and Right Side of the Machine ...	1-4	Usable sizes of media	1-14
Operation Panel	1-5	Caution in handling of medias	1-14
Pre-Heater	1-7		
Media sensor	1-7		
Carriage	1-7		
Capping station	1-8		
Pinch rollers and Feed rollers	1-8		

About installing this machine

Where to Install This Machine

Secure a suitable installation space before assembling this machine.

The place of installation must have enough space for not only this machine itself, but also for the printing operation.

Model	Width	Depth	Height	Gross weight
UJV55-320	5410mm (213.0in)	995mm (39.2in)	1440mm (56.7 in)	910 kg (2006.2lb)



- If the place to install the machine is exposed to strong sunlight around the window, draw a curtain to prevent the machine from being exposed to strong sunlight.

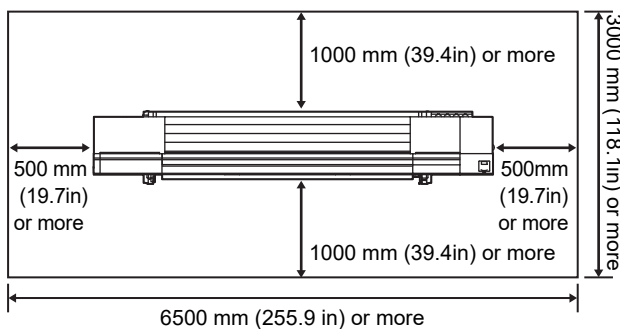

Working Environmental Temperature

Use this machine in an environment of 20 to 30°C to ensure reliable printing.

The heater temperature may not reach the set value, depending on the ambient temperature.

When this machine is used in a hot environment, the UV lamp may reach a high temperature. Then the machines may display a warning or error message and stop operation including printing.

About fixing machine

The leg of this machine has the level foot to fix the machine.

Before turning the power ON, make sure that the printer body is fixed with the leveling feet. The printer body may start moving during operation if it is not fixed with the leveling feet.

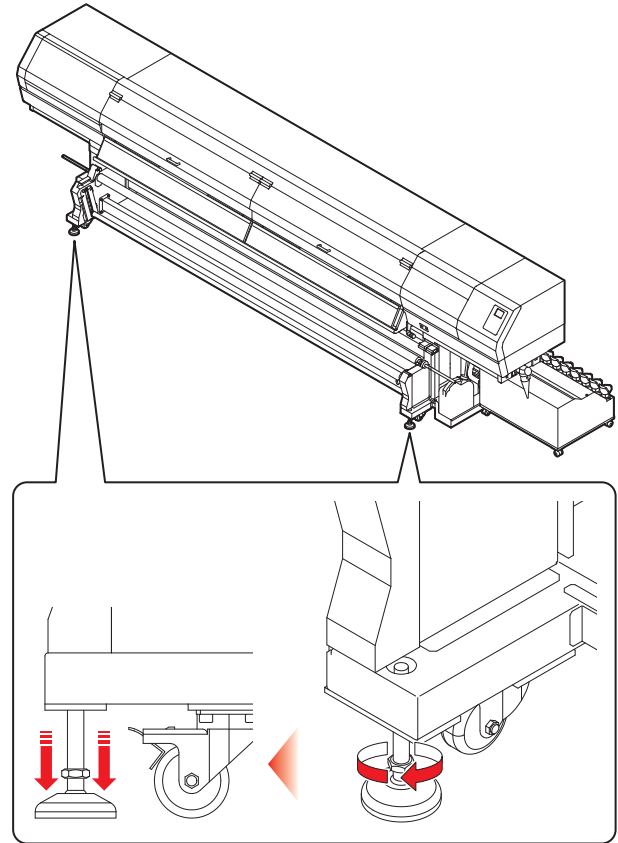

Moving This Machine



- When the machine is moved to any place other than on the same step-free floor, contact your distributor or our service office. If you move it by yourself, failure or damage may occur. Be sure to request your distributor or our service office to move this machine.

Names of Parts and Functions

Front Side of the Machine

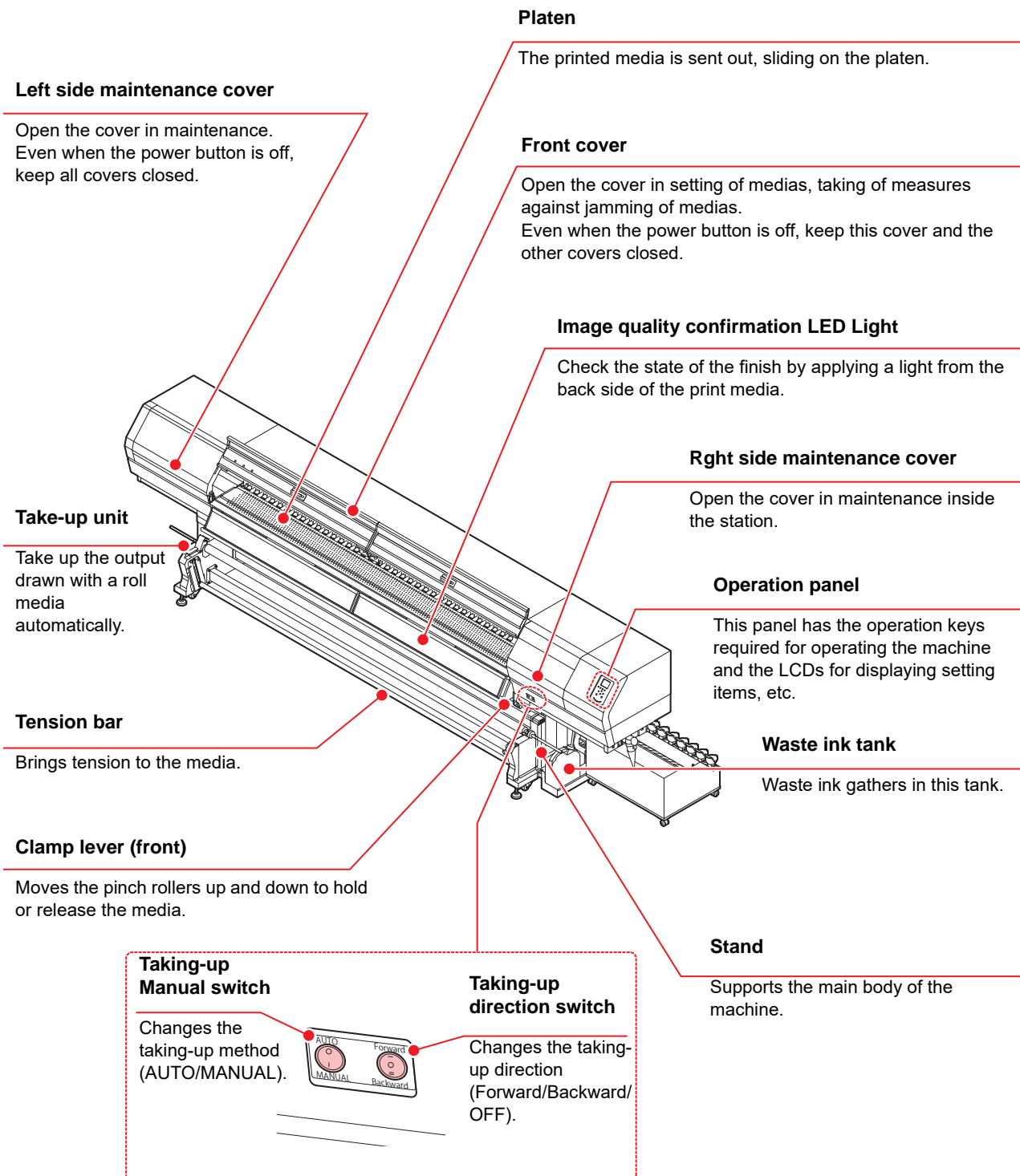

Rear Side and Right Side of the Machine

Feeding Manual switch
Changes the feeding method (AUTO/MANUAL).

Feeding direction switch
Changes the feeding direction (Forward/Backward/OFF).

Clamp lever (rear)
Interlocks with the clamp lever in the front of this machine.

Pre-heater
Preheats the media before printing. (Located inside the cover)

Rear cover
Open the cover in setting of medias, taking of measures against jamming of medias. Even when the power button is off, keep this cover and the other covers closed.

Roll holders
Uses when printing a media of vinyl chloride or photo paper.

Wide media set area (2 bars)
Set a wide media.

Tension bar
Brings tension to the media.

Ink supply unit
Set the ink tank.

Power switch for LED light
Turns on/off the image quality confirmation LED light.

AC outlet for LED light
Connect to the outlet of the image quality confirmation LED light.

Main power switch
Turns on/off the main power for this machine. Leave the main power turned on to prevent ink clogging.

AC inlet
Connect the power cable to the AC inlet.

USB 2.0 connector
This is USB2.0 interface connector.

LAN connector
This is Ethernet interface connector.

RS-232C connector
This is RS-232C interface connector.

Operation Panel

Use the operation panel to make settings for printing or operate this machine.

SEL key

Changes over the functions of the function keys ([FUNC1]–[FUNC3]).

FUNC1 / **FUNC2** / **FUNC3** key

Press this to set various functions or to do test printing. The function keys' functions are changed each time [SEL] key is pressed.

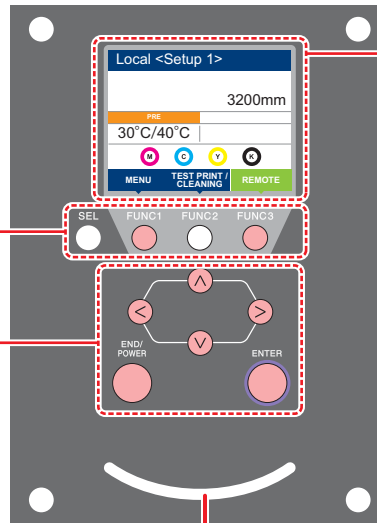

Display

Displays the following items:

- Printer status
- Set media width
- Heater temperature (current temperature/set temperature)
- Ink status ^{*1}
- Functions assigned to [FUNC1] to [FUNC3] ^{*2}

JOG key

Use these keys to shift the carriage or the media in [LOCAL]. Also use them to select an item of printing conditions.

END/POWER key

Cancels the last input value or returns the setting menu to the immediate higher level of the hierarchy. Also, press this to turn the power on or off. (Give it a long press to turn the power off.)

ENTER key

Registers the last input value as the setting value or goes to the immediate lower level of the hierarchy.

Status indicator lamp

Indicates the machine's status (printing, error occurred, etc).

Condition of Lamp	Condition of machine
OFF	Machine is in LOCAL mode, no print data has been received, and no errors have occurred.
Lit steady Light blue	Switched to Remote mode.
Flashing Light blue	Currently printing.
	In test printing: printing a pattern stored inside the machine.
Lit steady blue	Print data still remains in the machine.
Flashing red	Error has occurred.
Lit steady red	Error (SYSTEM HALT) has occurred.



- The [ENTER] key under the operation panel lights in blue when the power is turned on, and off when the power switch is turned off. The ink clogging prevention function is periodically operated even when the power switch is OFF if the main power switch keeps being ON. (Auto maintenance function) P.1-4











*1 : Ink Status

Status of the ink tank (remaining ink/error, etc.) is displayed using icons. Each icon is described below.

Icon	Contents																		
	<p>Displays the remaining ink amount in nine levels, in the order of the ink cartridge set in the slot. The remaining amount decreases moving to the right.</p> <table border="1"> <tr> <td></td> <td></td> <td></td> <td></td> <td></td> <td></td> <td></td> <td></td> <td></td> </tr> <tr> <td>ink full</td> <td>Approximately 1/8 consumed</td> <td>Approximately 1/4 consumed.</td> <td>Approximately 3/8 consumed.</td> <td>Approximately 1/2 consumed.</td> <td>Approximately 5/8 consumed.</td> <td>Approximately 3/4 consumed.</td> <td>Approximately 7/8 consumed.</td> <td>near end</td> </tr> </table>										ink full	Approximately 1/8 consumed	Approximately 1/4 consumed.	Approximately 3/8 consumed.	Approximately 1/2 consumed.	Approximately 5/8 consumed.	Approximately 3/4 consumed.	Approximately 7/8 consumed.	near end
ink full	Approximately 1/8 consumed	Approximately 1/4 consumed.	Approximately 3/8 consumed.	Approximately 1/2 consumed.	Approximately 5/8 consumed.	Approximately 3/4 consumed.	Approximately 7/8 consumed.	near end											
	Indicates that the ink cannot be used due to ink end or ink error.																		
	Indicates that ink has expired or that one month has passed after the expiration date. Please use quickly. Ink can no longer be used if two months have passed after the expiration date.																		

*2 : Functions assigned to [FUNC1] to [FUNC3]

Contents of functions assigned to [FUNC1] to [FUNC3] are described below.

Icon	Contents
	Displays "MENU" for setting functions.
	Displays maintenance functions such as test print, cleaning, etc.
	Shifts to Remote from LOCAL and starts printing.
	Displays adjustment functions such as Feed Comp, DROP.POScorrect, etc.
	Sets the heater temperature.
	Executes data clear.
	Suspends printing in Remote and shifts to LOCAL.
	Used for adjusting and resetting the waste ink amount. Use after disposing of the waste ink.
	When there are multiple items on the MENU screen or other screens, it moves to the next page.
	When there are multiple items on the MENU screen or other screens, it moves to the previous page.
	Used for completing confirmation when warning message has been displayed and so on.
	Used for turning functions OFF or cancelling them, for example, when turning heater settings OFF and so on.
	Some kind of setting or function is assigned. Operate according to the description of each function.
	Switches between enable/disable when selecting multiple items, for example, when selecting target head for cleaning and so on.
	The vacuum fan is always ON.
	The vacuum fan is only ON during printing and jog operation.
	Used for adjusting the head height.



- The color of icons changes according to the state of the printer.
 When the icon is green: The printer is in Remote mode.
 When the icon is dark blue: The printer is in LOCAL mode.

Pre-Heater

Preheats the media before printing.



- During the heating by the pre-heater, the pre-heater cover is hot on the backside of this machine. Before opening the backside cover or changing the media, allow the pre-heater to cool down sufficiently. Failure to do so may cause a burn injury.
- Before changing the existing media with a thin media, allow the pre-heater to cool down sufficiently. If such a change is made while the pre-heater cover is hot, the thin media might stick fast to the platen, or get wrinkled or curled.
- If the media floats as wave, press the [▼] button on the operation panel to feed the media.

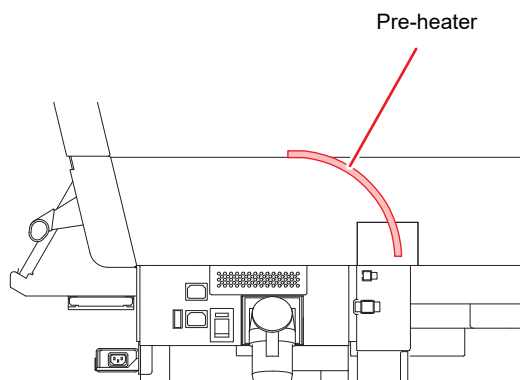
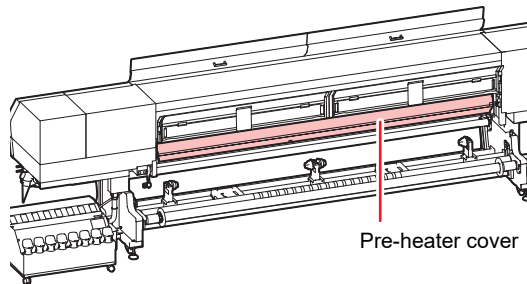

Media sensor

The media sensor detects the presence of the media. This machine has three media sensors on the pre-heater cover (in the rear).



- When setting a media, be sure to cover one of the media sensors located on the rear of the pre-heater cover. The media cannot be detected unless it is placed over the sensor.

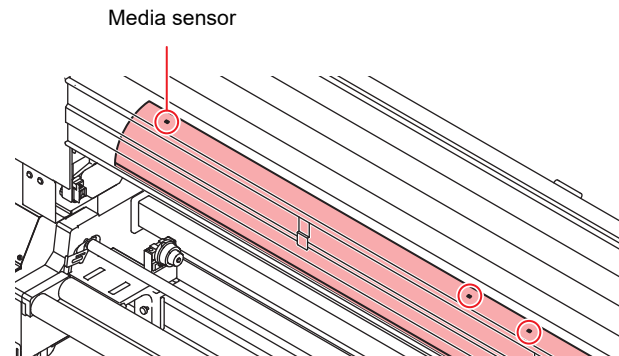

- When using twin rolls, set each of the media in such a manner as to cover over each of the two sensors located near the center of the pre-heater cover. Otherwise, this machine might be damaged.

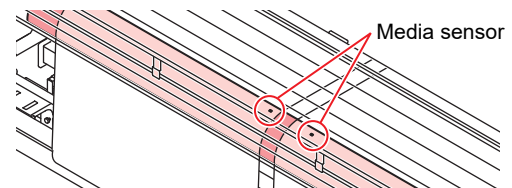

Carriage

The carriage has the ink head for printing, the LED UV unit.

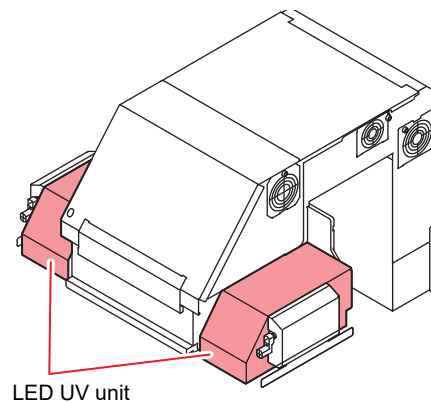

- Do not expose your naked eyes directly to the light irradiated from the LED UV when it lights.
- Do not touch the LED UV unit when it is being lit or just after it is set OFF. It may cause a burn injury, as it is very hot.

Capping station



- Be sure to wear the attached safety glasses in cleaning within the capping station to protect your eyes against ink. Otherwise, you may get ink in your eyes.

The capping station consists of the ink caps, the wiper for cleaning the heads, etc.

The ink caps prevent the nozzles in the heads from drying up.

The wiper cleans the nozzles in the heads.

The wiper is consumable. If the wiper is deformed or the media is stained, replace the wiper with a new one.

(P.4-20)

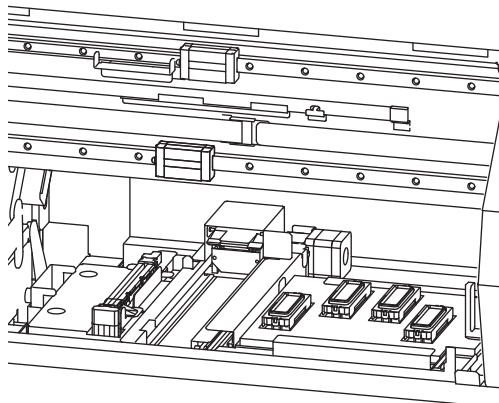

- If the capping station is subjected to sunlight or artificial light, the ink inside the capping station will become cured, resulting in reduced image quality and malfunctions. Therefore, the cover should be closed as soon as possible after maintenance is complete.

Pinch rollers and Feed rollers



- Keep the pinch rollers lifted up when this machine is not in use. If the pinch rollers are left lowered for an extended period of time, they can be deformed and fail to securely retain the media.

This machine retains the media with the pinch rollers and feed rollers. During printing operation, the feed rollers feed the media forward.

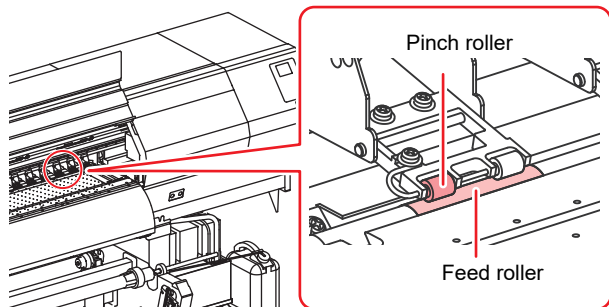

Connecting Cables

Connecting USB2.0 Interface Cable

Connect the PC and this machine with the USB2.0 interface cable.

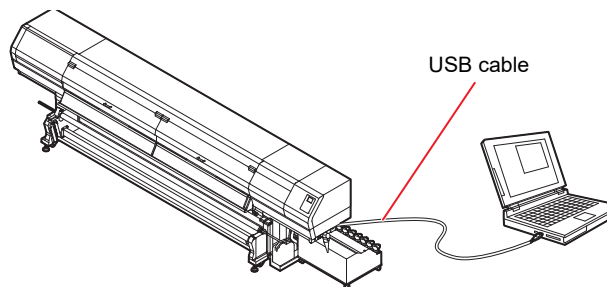

- Your RIP must be compatible with USB 2.0.
- Contact a RIP maker near your location or our office when the USB2.0 interface is not attached to the PC.

Notes on USB 2.0 Interface



- Your RIP must be compatible with USB 2.0.

● When two or more UJV55-320 machines are connected to one personal computer

When two or more UJV55-320 machines are connected to one personal computer, the personal computer may not recognize all the UJV55-320 machines normally.

Reconnect the unrecognized UJV55-320 machine to another USB port, if available, and check to see if it is recognized. If the UJV55-320 machine is not recognized by the newly connected USB port, use USB 2.0 repeater cables available on the market.

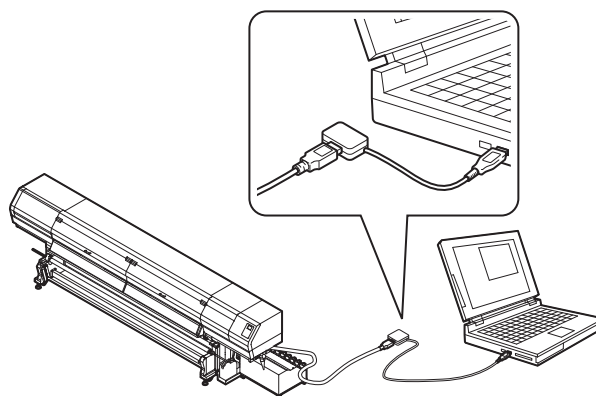

● Notes on peripheral devices in USB high speed mode

When a peripheral device (USB memory or USB HDD) to be operated in USB high speed mode is connected to the same personal computer that a UJV55-320 machine is connected to, the USB device may not be recognized. When UJV55-320 is connected to the personal computer to which an external HDD is connected via USB, the speed of data output to UJV55-320 may drop. That can cause the head unit to stop temporarily at the right or left end during printing.

● Removing USB memory

If a USB memory module is inserted in the personal computer to which a UJV55-320 machine is connected, click "Stop" in the "Safely Remove Hardware" window by following the instructions given there first and then remove the module.

Leaving a USB memory module inserted can cause [ERROR 201 COMMAND ERROR].

Copy the data onto the hard disk before outputting it for printing.

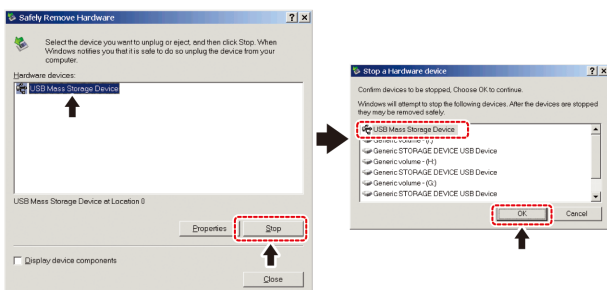

Connecting the LAN cable

When connecting LAN cable, be sure to follow the note below:

- Important!** • Surely insert LAN cable until clicking noise sounds.
- Do not plug in or unplug any cable during data transferring.

Printing Via a Network

If printing via a network, you need to configure your network with the following environment.

If you configure it with an inappropriate environment, it could cause printing to stop.

- Use LAN cables that are category 6 or higher.
- Use a switching hub and PC that support 1000BASE-T.

- Important!** • Set the PC sending the print data and the printer to the same network.
- You cannot connect via a router.

● If connecting directly to the printer

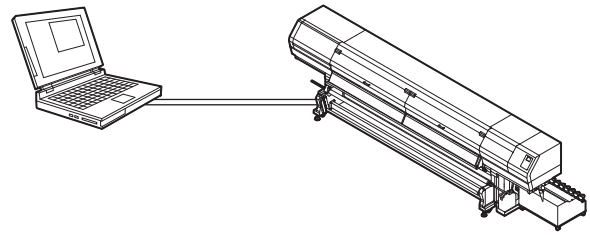

● If connecting via a switching hub

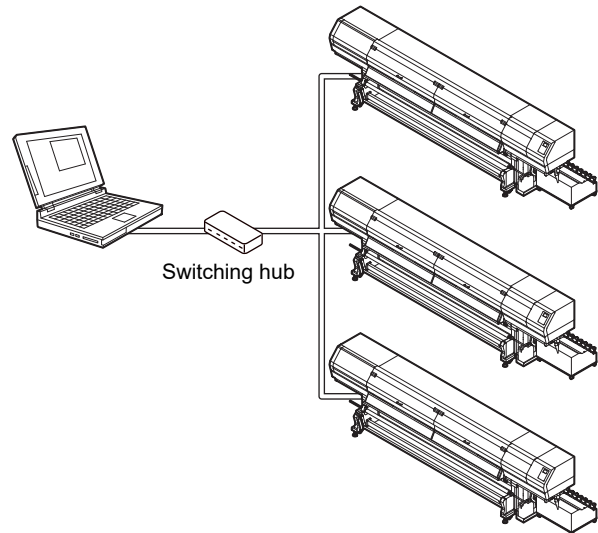

If the PC or device connected to the printer is not 1000BASE-T, you cannot perform printing. After connecting, check the following.

(1) Check the printer screen display.

- On the local screen or the media detection screen, press the [Enter] key several times to display the information screen.
- Check that "1000Mbps" is displayed for the LAN status item.

- Important!** • If "100Mbps", "10Mbps", or "No connect" is displayed, you cannot print using the LAN.
- If "100Mbps" or "10Mbps" is displayed, you can use event mail (☞ Chapter3 "Setting event mail function").

INFORMATION	
LAN Status	1000Mbps

(2) Check the green light of the LAN connector.

- After turning on the machine, the lamp for the LAN connector will light up as follows.

Color	Status	Condition
Green	ON	Connected with 1000BASE-T
	OFF	Connected without 1000BASE-T
Yellow	ON	Link-up
	Blinking	Receiving data
	OFF	Link-down

Important!

- If the yellow light only lights up, or is blinking, the status is not 1000Mbps. Check the specifications of the PC, device, and cables.

Connecting Power Supply Cable

You are not allowed to install the printer by yourself. Be sure to request MIMAKI's service personnel and an electrician to install the printer.



- The power supply specifications of this machine is as below:
Single-phase 200 to 240 Vac 18A (cannot be used with 100 V system)
- For the power supply to the main body of the printer, electrical work is required as described below. Request an electrician to perform electrical work.
- Socket installation onto the circuit breaker
- Grounding work
- Ensure that a wall outlet is available near the printer. Also ensure that the power cable can be easily unplugged whenever necessary.
- To prevent electrical shock hazard, it is prohibited for anyone other than electrician licensees to perform the electrical work for this printer.
- Take care not to miswire, which can result in a fire or an electric shock.



- When any power cable other than the supplied one is to be used, make sure that the cable is equivalent to one of the following types. Connect the cable as shown below.
- VCT-5.5m m² x33 cores (600 V)
- UL-AWG10x3C (600V)

For power supply connection, this printer uses the Type B plug and socket in compliance with IEC 60309.

When a socket construction meeting the plug of the power cable of this printer is required, use the supplied socket and perform construction between your switchboard and the socket.

Socket construction

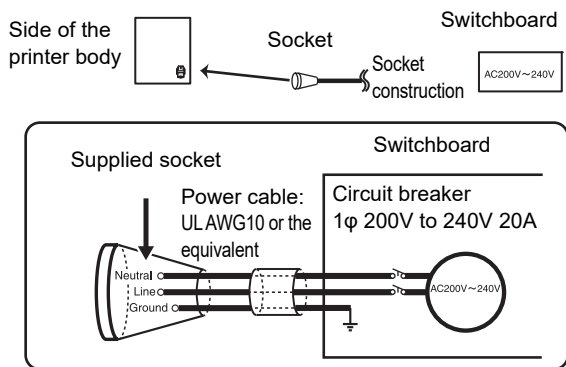

Fill ink in the ink tank and charging

Fill ink in the ink tank of this machine.



- Be sure to wear the attached safety glasses and gloves to perform the work. Ink may get in your eyes.

Rough standard for adding ink

You can check the current amount of ink in the ink tank of this machine (rough standard) with the ink remaining amount indicator below the ink tank.

The way to check the ink remaining amount indicator and the ink remaining amount are as below.

In addition, when this machine enters into the status of [Ink Near END] or [Ink End], the display indicate it.

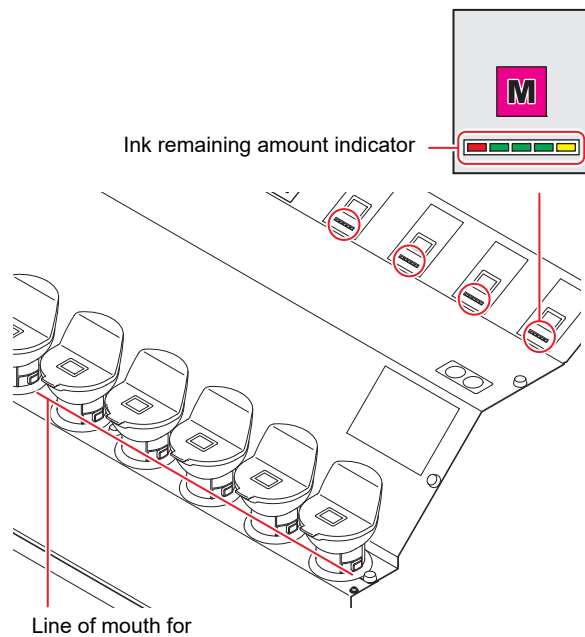

Notes before adding ink

Check the following before adding ink. Failure to do so could require all of the ink inside the ink supply unit to be discarded.

- **Type of ink**
- **Color of ink**

- **Expiration date of ink**

Check both expiration dates of the ink contained in the ink bottle for refilling and the ink tank of this machine. Check the label for the expiration date of the ink bottle. Press the [ENTER] key to check the expiration date of the ink remaining in the ink tank of this machine.

(P.3-26)

- **When the ink close to the expiration date is in the ink tank**

Use up the ink in the ink tank, then replenish a new ink. If replenish the new ink in the old ink, there is a possibility that the print quality is reduced earlier than that of the effective date of the replenished new ink.

- **When replenish the ink, use up within three months**

If use the ink which has passed more than 3 month from the replenishment, the print quality may be degraded even within its expiration date.

Status of ink remaining amount indicator	Status of ink amount and Current ink amount *1
	Ink end/Ink tank none
	Ink near end/ Ink remain : 400cc and less *2
	Ink remain : 400 to 1L and less than
	Ink remain : 1L to 1.5L and less than
	Ink remain : 1.5L to 2L and less than
	Ink remain : 2L to 2.5L and less than
	Ink full/ Ink remain : 2.5L to 3.2L and less than
	Ink over/ Ink remain : 3.2L or more *3

*1. The ink remaining amount indicator is only rough standard. For ink filling, it is recommended to check the liquid level from the mouth for adding ink.

*2. "INK NEAR END" at 400cc and "INK END" at 300cc.

*3. The ink tank set in this unit can replenish the ink by up to 3.6L, but there is a possibility that ink would spill from the mouth for adding ink. When the orange lamp is lit, please do not replenish the ink.

1

Insert the ink IC chip into the ink IC slot.

- Use the IC chip attached to the ink bottle for refilling.
- Insert the ink IC chip facing the contacts of IC chip up.

Important!

- Do not dirty or damage the contact of ink IC chip. It may cause not to read the stored information correctly.

2

Confirm the information of ink IC chip, and press the **[ENTER]** key.

- Confirm the color, ink type, capacity displayed on the display. If incorrect, press [END/POWER] key and reenter.
- When an error message such " WRONG INK IC " is displayed, remove the IC chip once and reinsert it.

Important!

- The ink IC chip charged once cannot be undone. Be sure to press [ENTER] key after the displayed information is confirmed.

3

Confirm the charge completion display.

- When the ink charging is normally completed, the new ink ink expiration date is displayed.
- Reinsert the IC chip when an error occurs.

Important!

- Do not remove the ink IC chip or turn OFF the power to this machine during charging. Doing so may cause a failure to the equipment or the ink IC chip.

1

4 When charging is complete, remove the IC chip.

Important!

- After charging is complete, be sure to remove and dispose of the IC chip. Do not reuse IC chips.
- If the error message "INVALID INK CHARGE" appears on the display
- Charging was not possible for one or more of the following reasons:
 - (1) Faulty IC chip
 - (2) The remaining amount of ink managed by this machine is "FULL".
 - (3) Attempting to charge ink that has passed its expiration date

5 Take out the ink bottle, and slowly shake it twenty times and more.

- To prevent ink from leaking when you shake it, wear gloves and cover the ink bottle cap with a paper towel etc. Being in that status, slowly shake it twenty times and more by flowing ink.

Caution

- Before shaking it, check that the cap is firmly closed.
- If you shake it too strong, it may cause ink leakage. Therefore, perform this carefully.
- If the remaining amount of ink is less, ink in the bottle cannot be beaten enough. Tilt the ink bottle until it becomes vertical.

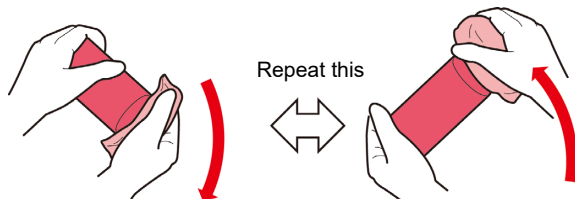

Cover with paper towel firmly and shake ink slowly

6 Remove the ink bottle lid.

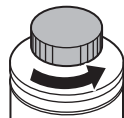

!

- If the mouth of the ink bottle is fitted with a seal, cut this open using a craft knife. Be careful not to drop the cut seal into the bottle.

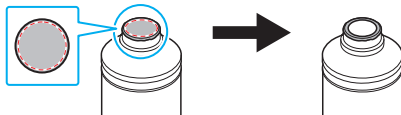

7 Remove the cap of the ink tank.

- First, cover the cap with a waste cloth etc. to prevent your hands from getting dirty and then remove it.

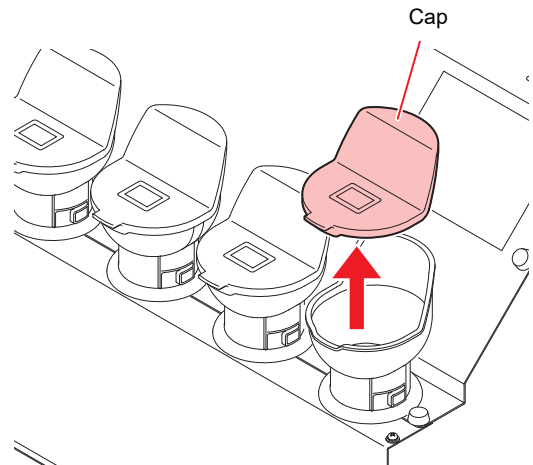

8 While checking the ink remaining amount indicator, add ink.

- Depending on the ink type, aluminum sheet adheres to the bottle top surface. In such a case, remove it with a cutter.
- While checking the ink remaining amount indicator below the ink tank, add ink. For details, refer to P.1-25 "Rough standard for adding ink".

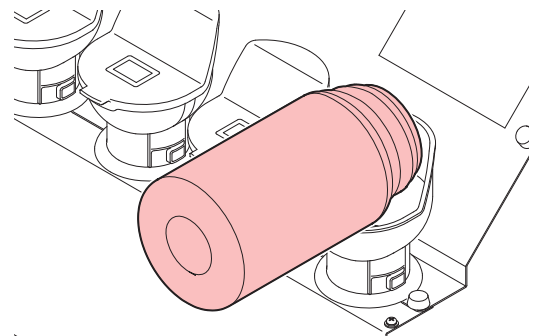

9 Attach the ink tank cap firmly.

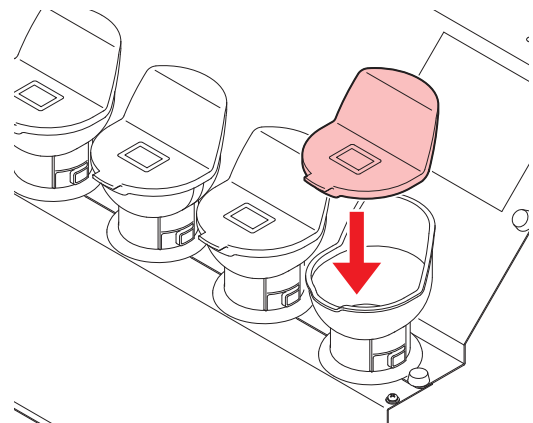

Important!

- Attach the cap firmly.
- UV ink may be cured by ultraviolet. If the cap is not attached firmly after you add ink, it may cause adverse effects on ink in the tank and it may become unusable.

About IC chip

- The IC chip has information of ink color, remaining amount of ink, expiration data, etc.
When filling the ink, insert the IC chip packed with the ink bottle into the IC chip inserting port.
- If an IC chip that is not paired with the ink bottle is inserted, ink can not use.
- The mark indicating color information is pasted on the IC chip.

Ink color	Indication mark
Black	● (one black circle)
Cyan	● (one blue circle)
Magenta	● (one red circle)
Yellow	● (one yellow circle)
White	○ (one white circle)
Light cyan	●● (two blue circles)
Light magenta	●● (two red circles)

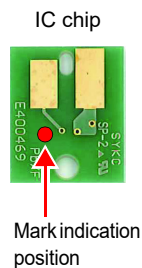

When [INK NEAR END] is displayed

There is a little of ink left. You can print continuously, however, ink may end during printing. It is recommended to add ink as soon as possible.

Press the [ENTER] key in Local to check the ink tank that requires refilling in Local Guidance. (☞ P.3-26)

When [INK END] is displayed

When it becomes Ink end (remaining amount of ink is none), the machine cannot print. Refill ink.

About ink expiration date

You can check the expiration date of the ink in this machine by doing the following:

- (1) In Local, press the [ENTER] key several times until [Expiration] is displayed.

The ink expiration date is indicated on the Ink bottle. Expired ink may cause printing defects or alter the color tone. Printing is possible even if the ink has passed its expiration date. Nevertheless, we recommend replacing with new ink or use up as quickly as possible.

Example :The expiration date is April 2020

- May : Replace with new ink or use up as quickly as possible. Printing is possible.
- June : Replace with new ink or use up as quickly as possible. Printing is possible.
- July : Printing is not possible.

Important!

- When the ink is unusable, printing and/or cleaning operation and charging with the IC chip (☞ P.1-11) are disabled.
In that case, please perform the follow operation.
- (1) Discard the ink remaining in the ink tank of the machine.
- (2) Refer to "Replace the ink tank and ink filter" on step 5 of P.4-22, and reset the ink charge information.
- (3) Press the [END/ POWER] key several times to return to the local.
- (4) Refill with new ink. Refill with new ink. (☞ P.1-11)

Caution in handling of ink bottles



- If you get ink in your eyes, immediately wash your eyes with a lot of clean running water for at least 15 minutes. In doing so, also wash the eyes to rinse ink away completely. Then, consult a doctor as soon as possible.
- If the ink bottle is moved from a cold place to a warm place, leave it in the room temperature for three hours or more before using it.
- Make sure to store ink bottles in a cool and dark place.
- Store ink bottles and waste ink tank in a place that is out of the reach of children.
- Request an industrial waste processor for processing of empty ink bottles.
- Be sure to thoroughly consume the ink in the ink bottle, once it is opened, within three months. If an extended period of time has passed away after opening the ink bottle, printing quality would be poor.
- Do not shake ink bottles violently. This may result in ink leakage from the ink bottles.
- Do not touch or stain the contacts of the IC chip. This may cause damages on printed circuit boards.



Media

Usable media sizes and notes for handling are described.

Usable sizes of media

Model	UJV55-320		
Type of Recommended media *1	PVC film, tarpaulins, transparency film		
Maximum width *2	3250mm		
Minimum width	210mm		
Maximum printing width	3200mm		
Roll media		When using feeding unit	When using roll holder
	Thickness	1mm or less (Should not cause trouble during media transport)	
	Roll outside diameter	Φ300mm or less	Φ180mm or less
	Roll weight *3	100kg or less	18kg or less
	Roll inside diameter	When using take-up unit and feeding unit: 3 inches When using roll holder: 2 or 3 inches	
	Printing surface	Regardless of inside and outside	
	Roll end treatment	The roll end is gently fixed to the core with weak-adhesive tape or weak glue for easy removal.	

*1. Depending on a media to be used, it may not adhere or the media may not be properly fed. Always try and check the media to be used beforehand.

*2. The maximum width including paper core is 1524mm (60 inch) when twin rolls are used.

*3. When holding the right and left side of roll media and when there is no deflection on the roll

Caution in handling of medias

Pay attention to the followings for handling of medias.

Important!

- **When handling media, wear the gloves.**

If you touch the media with your bare hand, the media may be stained due to fingerprints or oil of your finger. Be careful about it.

- **Do not leave the media with the heater ON for a long time.**

Waviness may occur on the media and it may cause media clogging.

- **Use media recommended by MIMAKI to ensure reliable, high-quality printing.**

Set the heater temperature to meet the characteristics of the media.

- **Set the temperature of the Pre-heater according to the type and characteristics of the media used.**

Automatic temperature setting can be made on the operation panel by setting the profile on the dedicated RIP. For setting on the RIP, refer to the instruction manual for your RIP.

- **Pay attention to the expansion and contraction of the media.**

Do not use media immediately after unpacking. The media can be affected by the room temperature and humidity, and thus it may expand and contract.

The media have to be left in the atmosphere in which they are to be used for 1 day or more after unpacked.

- **Do not use curled media.**

This may result in paper jamming.

If a regular-sized coated sheet of media is rolled and stored, the coated side has to face outside.

- **Be careful to dusts on the edge face of the media.**

Some rolls have dusts contained in the package gathered on the edge surface of the roll. If you use as it is, the drawing quality may be degraded due to nozzle missing or ink drops. Be sure to set the roll after removing dusts adhering on the edge face of the roll.

Chapter 2

Basic Operations



This chapter

describes procedures and setting methods for ink and media preparation, and printing.

Workflow	2-2	Set media by using the narrow take-up device (twin rolls)	2-19
Turning the Power ON/OFF	2-3	Setting leaf media	2-20
Turning the Power ON	2-3	Removing the taken-up media	2-21
Turning the Power OFF	2-3	Changing the printing origin	2-22
Setting a Media	2-4	Preparing for the Heaters	2-23
Adjusting the Head Height and Jam sensor Height	2-4	Changing the Temperature Settings for the Heaters	2-23
Note for media setting	2-4	Test Printing	2-23
Setting a roll media	2-5	Test Printing	2-24
Use the image quality confirmation LED light to check the print	2-10	Head Cleaning	2-24
Setting a narrow roll media	2-12	About head cleaning	2-24
Setting two narrow roll media (twin rolls)	2-15	Perform head cleaning depending on the test printing result	2-24
Setting media by using the narrow take-up device	2-18	Setting of Media Correction	2-25
Set the settings of Feeding unit and Take-up unit of Machine Setup to "OFF"	2-18	Setting of Media Correction	2-25
Lower the tension bar located on the front of the machine to its lowest position to remove the roll shaft	2-18	Correct the ink drop position for bidirectional printing	2-26
Set media by using the narrow take-up device	2-18	Printing Data	2-27
		Starting a Printing Operation	2-27
		Stopping a Printing Operation	2-27
		Deleting Received Data (Data Clear)	2-27

Workflow

Turning the Power ON/OFF

Referring to “Turning the Power ON/OFF” (☞ P.2-3).

Setting a Media

Referring to “Setting a Media” (☞ P.2-4).

Test Printing

Referring to “Test Printing” (☞ P.2-22).

Head Cleaning

Referring to “Head Cleaning” (☞ P.2-23).

Correct the media feed amount

Referring to “Setting of Media Correction” (☞ P.2-24).

Correct the ink drop position for bidirectional printing

Referring to “Correct the ink drop position for bidirectional printing” (☞ P.2-25).

Printing Data

Referring to “Printing Data” (☞ P.2-26).

Turning the Power ON/OFF

Turning the Power ON

This machine is provided with the following two power switches:

Main power switch :

It is located on the side of this machine. Keep this switch ON all the time.

[END/POWER] key :

Normally, use this key to turn the power ON/OFF.

The nozzle missing prevention function periodically operates even with the [END/POWER] key turned OFF when the main power switch is turned ON.

- Important!**
- Turn the power ON after the front cover and maintenance cover are closed.

1 Turn the main power switch ON.

- Set the main power switches located on the side of this machine to the "I" side.

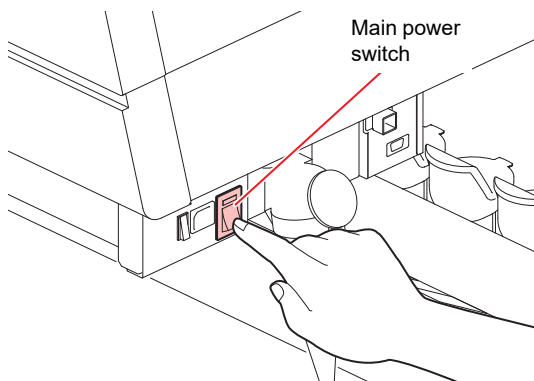

2 Turn the power on, by pressing the [END/POWER] key.

- The machine enters LOCAL.

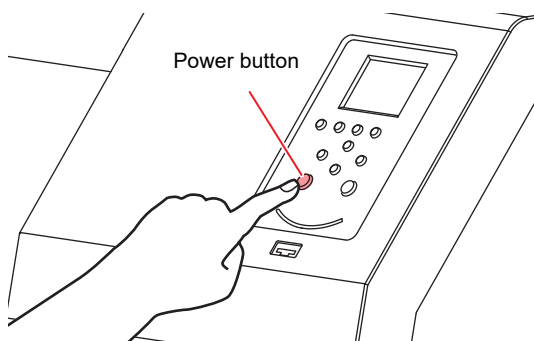

- The firmware version is displayed when the power is turned ON, and the machine performs its initial operation.

3 The machine enters LOCAL.

4 Turn ON the power of the connected PC.



- Always make the main power switch ON. If you leave it OFF, it may cause nozzle missing of the head. In some cases, recovery may become difficult.

Turning the Power OFF

When having ended the operation of the machine, turn the power OFF by pressing the power button located on the front side.

Check the following items when turning the power OFF.

- If the machine is receiving data from the PC or if there is any data that has not been output yet
- If the head has returned to the capping station
- If any error has occurred (☞ P.5-13 "Error messages")

1 Turn OFF the power of the connected PC.

2 Turn the power off, by giving the [END/POWER] key a long press.

- Do not turn OFF the main power switch located on the side of the machine.
- To use this machine again, press the [END/POWER] key.

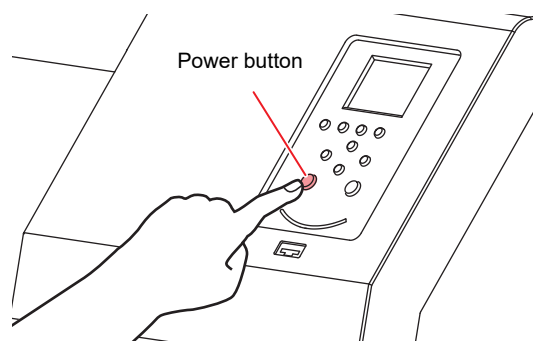

Cautions about Turning the Power OFF

● Do not turn the main power switch OFF.

When the main power switch is ON, the power periodically turns ON and the nozzle missing prevention function (flushing function) operate.

When the main power switch has been turned OFF, the auto maintenance functions, such as flushing, do not operate, and this may cause nozzle missing.

● Keep the front cover and the maintenance cover closed.

If any of the covers is opened, it may cause the ink become cured due to ultraviolet rays. In addition, it will not work auto maintenance functions such as flushing.

● Turn the power OFF after having checked the position of the head.

If the power is turned OFF in a state where the head has not returned to the capping station, the head dries, which may cause nozzle missing.

In this case, turn the power ON again and check that the head has returned to the capping station, and turn the power OFF.

● Do not turn the power OFF during printing.

The head may not return to the capping station.

● After having turned the power switch OFF by pressing [END/POWER] key, turn the main power switch OFF.

When turning the main power switch off for moving the machine or for solving the error or the like, press the [END/POWER] key a long time on the front of the machine, check the display is turned off on the operation panel, and turn the main power switch off.

Setting a Media

This machine can be used with a roll media and leaf media.

For usable media, refer to P.1-14 "Usable sizes of media".

Adjusting the Head Height and Jam sensor Height

Adjust the head height and Jam sensor height according to the thickness of the media you use.

1 Move the carriage to the platen.

- (1) Press the [SEL] key twice on the Local machine to display (HEAD HEIGHT) on [FUC3]
- (2) Press [FUC3] (HEAD HEIGHT) key.
- (3) Press [ENTER] key.

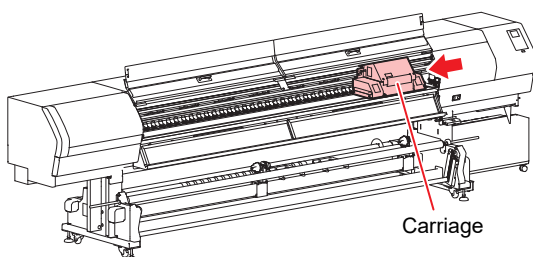

2 Adjust the height-adjusting lever according to the media.

- Adjust the position of the lever, referring to P.2-4 "For the Adjusting Lever and the Range".
- Set the head height-adjusting lever to the highest stage or the lowest stage. Setting it to the intermediate height, a printing fault can result.
- Adjust the jam sensor height-lever to the same position as the head height adjustment lever.

- Important!** Do not adjust the height-adjusting lever when the print head is capped. Doing so may damage the machine.

Head height-adjusting lever

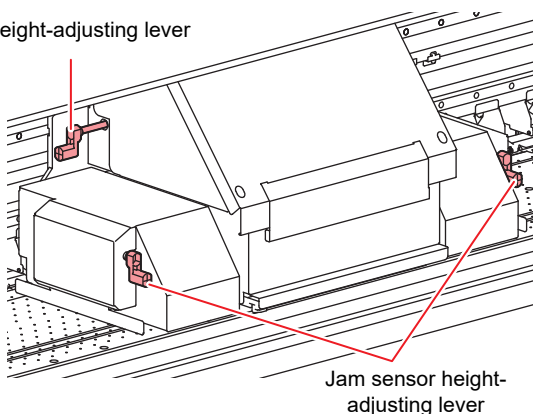

3 Return the carriage to the station position.

For the Adjusting Lever and the Range

Lever position	Distance between platen and head	Recommended media
Vinyl Standard	1.7mm	0.3mm or less (PVC film)
Banner Standard	1.9mm	0.5mm or less (Tarpaulins, FF)
High	2.6mm	Used, depending on the situation including a wavy media or the occurrence of cockling.
MAX	3.3mm	



- Please raise the lever when the media is prone to gather dust in the head or is often stained with ink traces.



In the following cases, perform P.2-25 "Correct the ink drop position for bidirectional printing".

- The lever position is changed.
- The head height is not changed, but the media thickness is changed.

Note for media setting

When setting media, read the following notes carefully.



- Take care not to drop the media on your foot when setting the media. It may cause an injury due to the media.
- When setting a roll media, work by two or more people. Otherwise, you may hurt your back by the weight of the roll media.
- When you raise the clamp lever and cut the media with your tools (cutter, scissors, etc.), be sure to check each item below:
 - (1) Make TAKEUP setting in "TakeUp" of the machine setting "OFF". (☞ P.3-14)
 - (2) Check that the tension bar is at the highest position.



In the following cases, the media may not be detected correctly.

- When setting a transparent media / when a media is exposed to direct sunshine.
- Do not use a printed media. Otherwise, ink can adhere to the pinch rollers and media may be stained or may not be detected.
- Straighten the significantly or internally curled media to be fed along the platen.
- If the media is left set on the machine for a long time, the media may form an irregular surface for the heat from the heater. If printing on such an irregular surface, the media may rub on the head. If an irregular surface is found under the media, feed the media with the [q] key to avoid printing on the irregular surface, and set a new origin. (☞ P.2-21)
- When setting a media, place the media in the center of the machine. If the media is set to the right or left, the media may not be transported normally.

Setting a roll media

Important!

- Narrow roll media may slip on the wide media set area and feeding cannot be performed properly. For setting a narrow roll media, refer to "Setting a narrow roll media" (P.2-12)



When using a take-up device, it is recommended to set the media with its print-side facing inside.

- This machine allows a media to be set with its print-side facing either inside or outside. Setting the print-side facing inside reduces the variations in tension caused by the changes in the media diameter occurring when the media is taken up, and thus secures stable take-up.

1

Put the roll media onto wide media set area on the backside of unit.

- Put roll media at the center of the wide media set area.

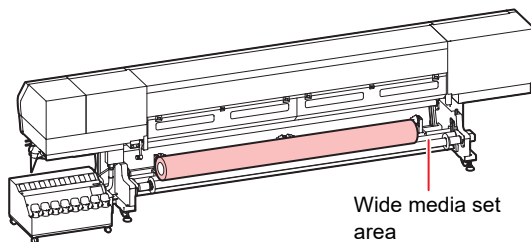

2

Open the front cover and rearcover.

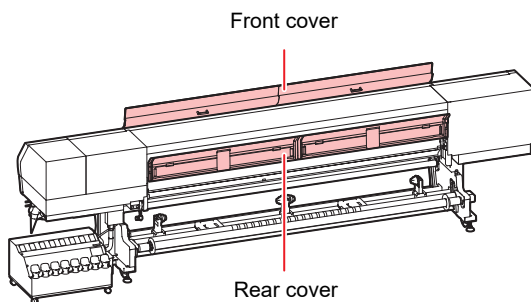

3

Move the media press to outside.

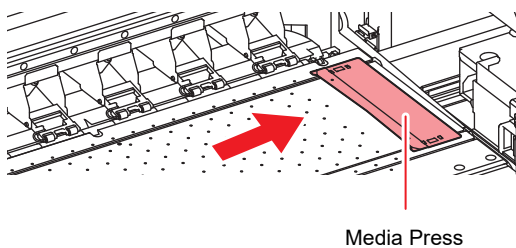

4

Set the roll guide for right and left.

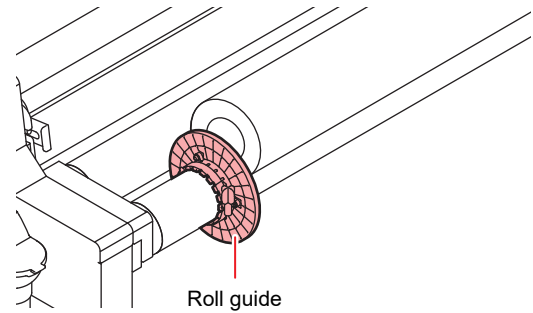

(1) Move the roll guide to the position of 1mm away from the media (paper core).

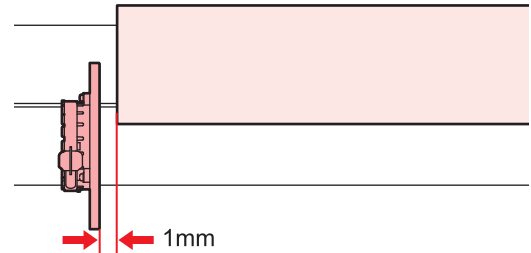

(2) Rotate the knob and fix the roll guide.

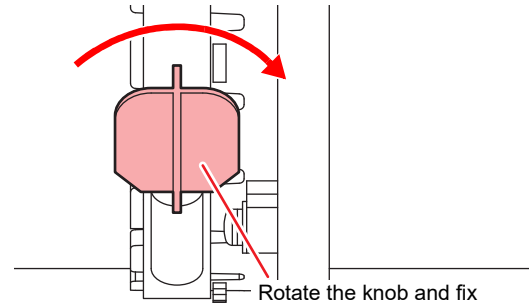

- Set the roller guide in relation to the paper core if the paper core is longer than the media. Failure to do so can result in a feeding fault.

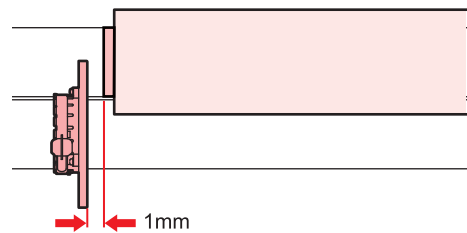

(3) Check that the roll guide is attached vertically against the feeding roll shaft.

(4) Feed the media and check that the roll guide does not apply any stress on the media/ the paper core.

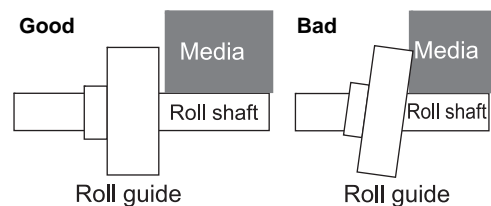

- If you perform printing with the status that the roll guide applies stress on the media/ the paper core, it is possible to detect media end by mistake.

2

5 On the backside of unit, set the feeding device.

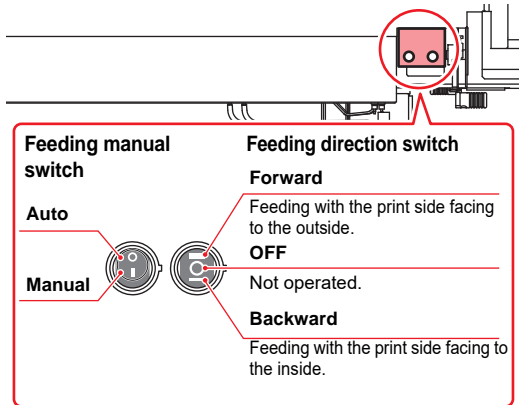

If the print-side is inside of roll,

(1) Set the Feeding direction switch at the "Forward" position (upward).

If the print-side is outside of roll,

(1) Set the Feeding direction switch at the "Backward" position (downward).

6 Raise the tension bar on the backside to the highest position, and lock the bar.

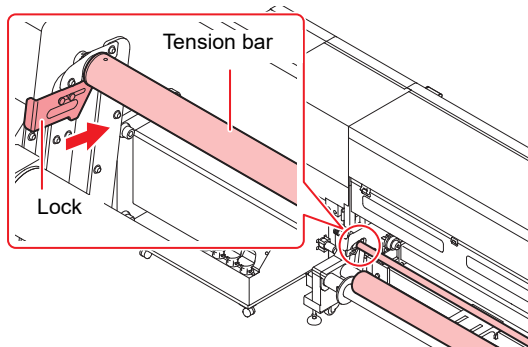

7 Pass the media through under the tension .

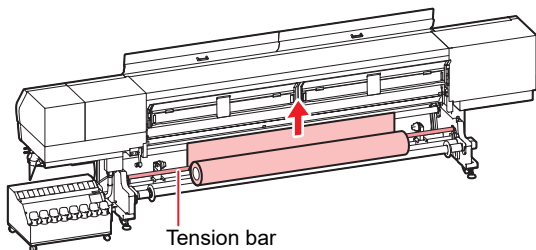

8 Set the feeding manual switch to "Manual", and pull the media a little longer.

- Pull the media out of the roll so that the media can be grasped from the front of the machine.

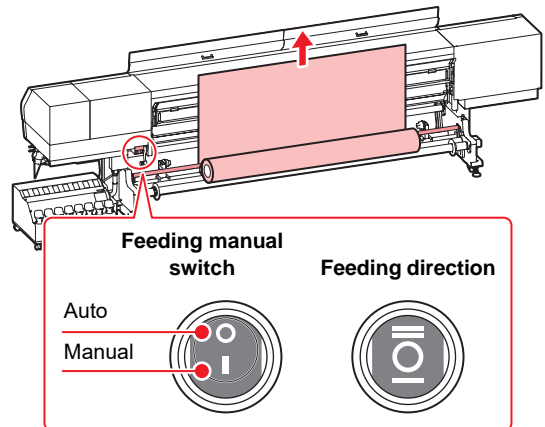

Route for the paper of its print-side inside.

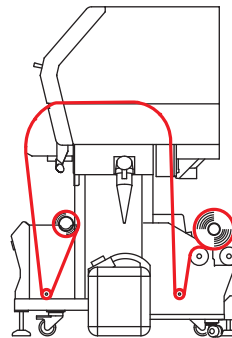

Route for the paper of its print-side outside.

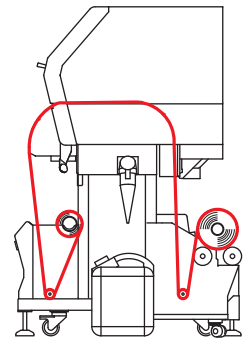

9 Slide the media from the back to the front.

- Make the Feeding manual switch "AUTO".

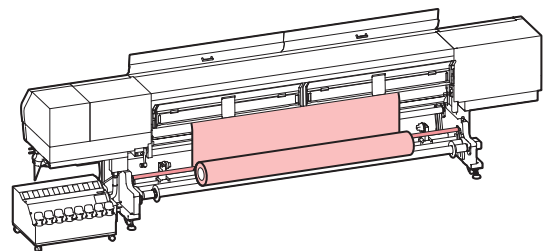

- Insert the roll media between the platen and the pinch roller, and slide it to the front.
- Pull the media out to the front of this machine with enough length.



- You can injure your hand if setting the roll media with a bare hand due to the narrowness of the media feeding route. Wear gloves when setting the roll media in order to prevent injury.

10 Close the rear cover.

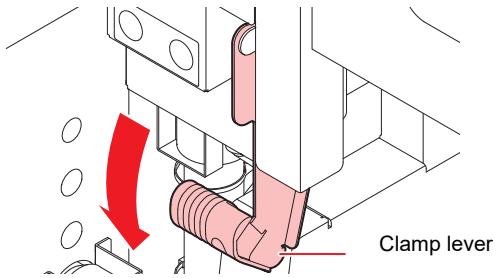
11 Push down the clamp lever to hold the media.**Important!**

- You can achieve stable media feeding by pulling the media from in front of the machine so that the media tension is even on the left and right when you push down the clamp lever.

12 Set the feeding manual switch to “Manual”, and feed the media about 10 cm.

- After feeding the media, Make the Feeding manual switch “AUTO”.

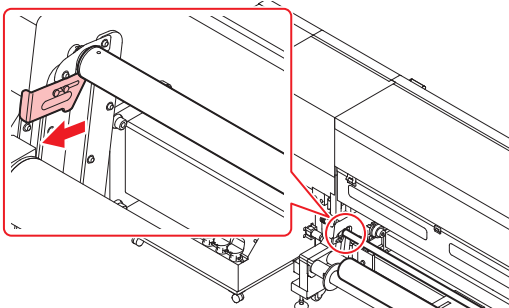
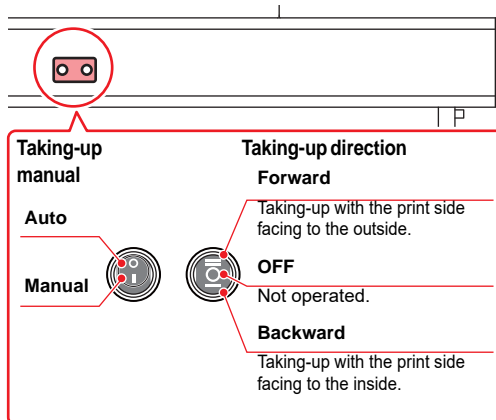
13 Release the lock of the tension bar.**14** Prepare for the take-up device.

- Set the taking-up direction switch to “OFF” (Center)
- Set the taking-up manual switch to “Auto” (Lower)

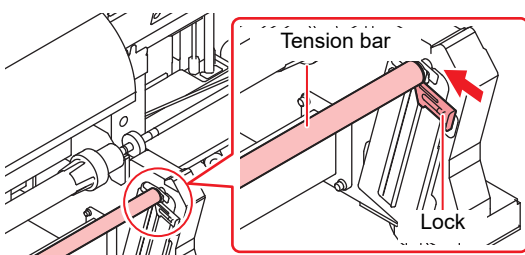
15 Raise the tension bar on the front side to the highest position, and lock the bar.**16** Feed the media to the tension bar.

- Pressing the [▼] key, feed the media until the tension bar at the rolling side is being hidden.
 - Check the media end is not caught into the slot on the platen, and feed the media.

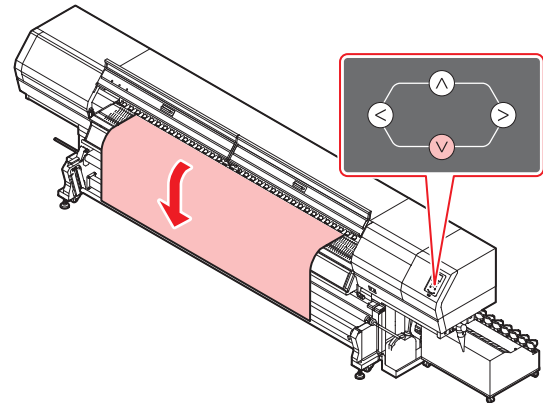
**17** Fix the media to the roll shaft.

- Route the media from the front side of the tension bar, and fix the media in the center of the roll shaft with adhesive tape.

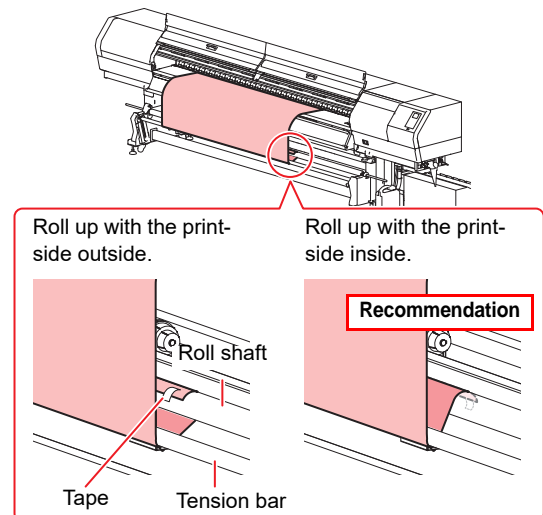

- In the same manner, fix the left side and right side of the media.
 - Pull roll media evenly for right and left, check that there is no slack or waviness on the media, and paste tape in numerical order.
 - When you place the tape, consider the rolling-up direction.

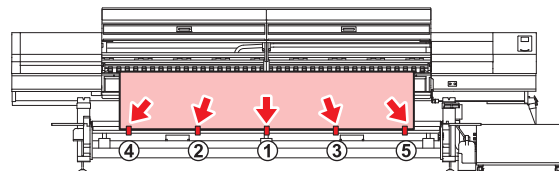

- 18** Press  to feed the media about 10 cm, and then release the lock of the tension bar.

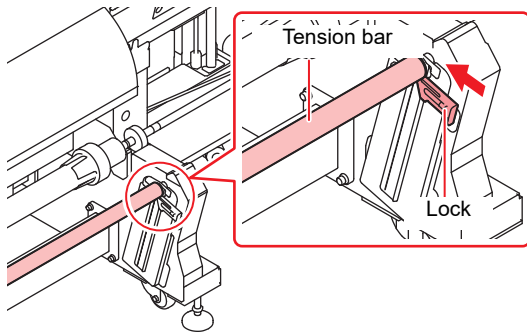

- 19** Roll up the media.
- (1) Set the taking-up direction switch to "Forward"/ "Backward" according to the taking-up method.
 - (2) Press , and rotate the roll shaft 2-3 times to take up the media.
 - (3) Press the [ENTER] key.

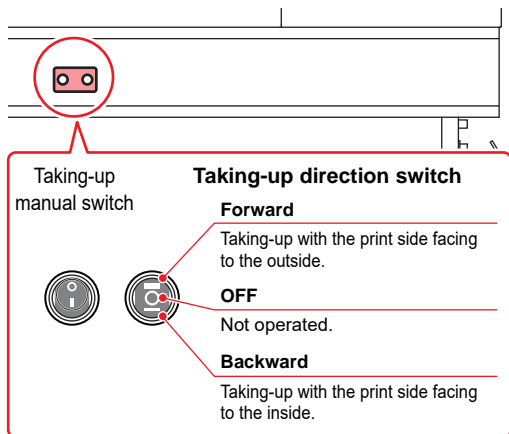

- **To take up the media with its print-side facing inside:**
Set the taking-up direction switch to "Backward".
- **To take up the media with its print-side facing outside:**
Set the taking-up direction switch to "Forward".
- **To stop taking-up:**
Set the taking-up direction switch to neutral (OFF).



- When using a take-up device, it is recommended to set the media with its print-side facing inside.**
- This machine allows a media to be set with its print-side facing either inside or outside. Setting the print-side facing inside reduces the variations in tension caused by the changes in the media diameter occurring when the media is taken up, and thus secures stable take-up.

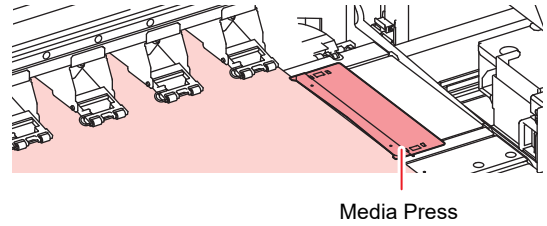

- 20** Hold the media with the media press gently.
- Set the media so that no media sticks out from the right end pinch roller to the right side.
 - When using a thick media(0.6 to 1.0mm), remove the media press from the media before printing.

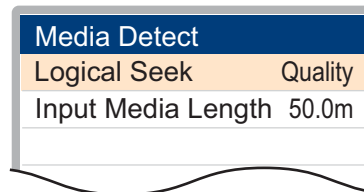

- 21** Close the front cover.

- 22** Press the  key to select "ROLL" .
- If the [Setting the Display of Media Detection] of Machine Setup set in "AUTO" (P.3-16), the machine automatically detects the media width. If set in "MANUAL", refer to P.2-10 "Detecting media width when media detection method is "MANUAL""
 - When the detection of media width is over, move to the setting screen of logical seek.



- 23** Setting the Logical Seek.
- (1) Press   to select the set value.
 - Set value : Media/ Data/ Quality
 - (2) Press the [ENTER] key.
- When [Media Remain] of the machine setup is "ON" (P.3-15), you are prompted to enter the media remaining amount. (P.2-10)



- When you do not use the take-up device, feed the media until the media reaches the floor, and then print. If you print with the media out of contact with the floor, the media feed amount varies during printing, causing poor printing quality.

When take-up the print media using the paper core

In stead of directly taking-up to the roll shaft, set the paper core to the roll shaft and take-up to the paper core. When removing the wound media from the roll shaft, you can remove the paper core media is wound from the roll shaft.

- 1 Open the cover of the take-up device on the front left side of the machine, and take out the roll shaft.

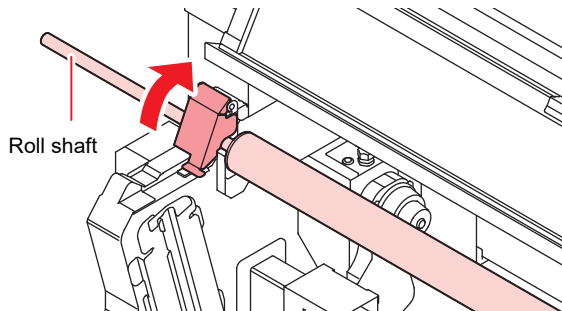

- 2 Through the paper core to the roll shaft, mount the take-up roll holder at both ends of the paper core.

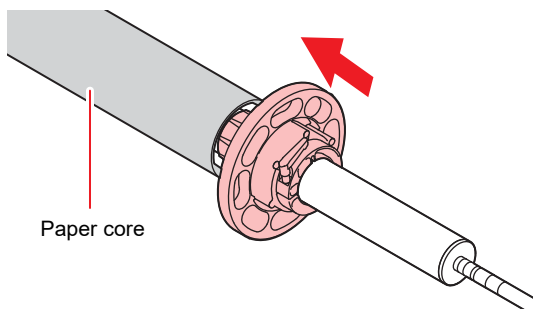

- 3 Replace the roll shaft, close the cover of the take-up device.

- When cover remains open, an error message is displayed and you will not be able to operate such as printing.

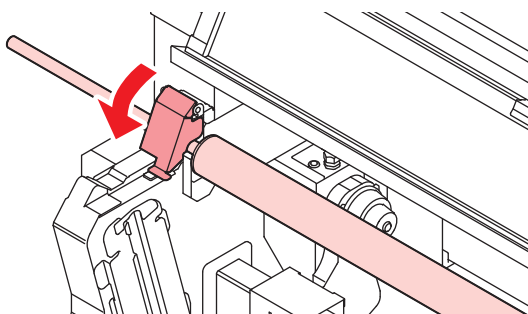

- 4 Refer to “Setting a roll media” on step 16 of P.2-5, and pull out the media until the paper core.

- Pull out the media so that the right and left are equalized.

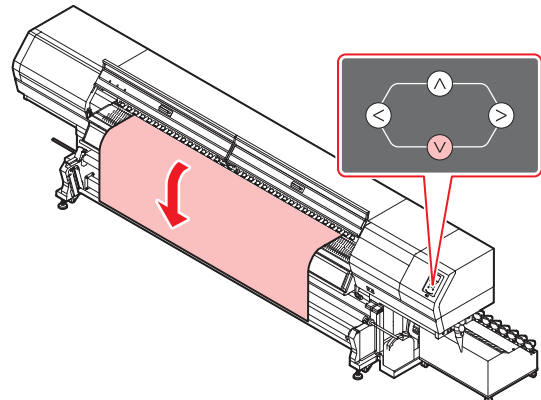

- 5 Firmly insert the take-up roll holder which was mounted in Step 2 into the paper core and fix.

- (1) Insert the roll holder (right and left) in a paper core and tighten with the fixing screw.

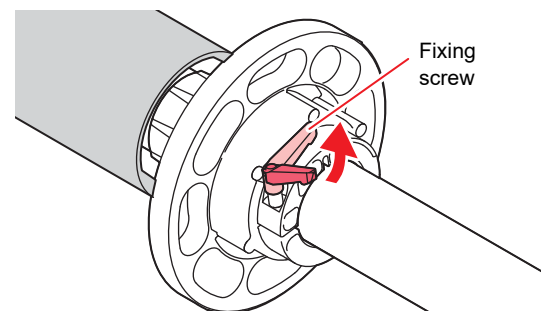

Important!

- When you fix the roll holder, please do not lift the lever of the fixing screws. When the entire fixing screws are raised above, screws idle and can not be fixed.

- (2) Turn the handle of the take-up roll holder to tightly secure the paper core.

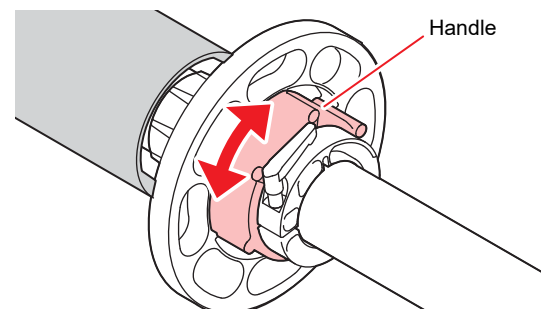

Important!

- As the paper core is not idling in the middle of taking up the media, please tightly secure the paper core.
- When you fix the paper core, keep it within the range indicated with the “movable range seal” attached to the paper core.

- 6 Perform the operations in “Setting a roll media” step 9 and later.

About entering media remaining amount

When you set [Media remaining amount display] to "ON" (P.3-15), you are prompted to enter the media remaining amount after completing the setting of the Logical Seek.

- 1 When the setting of the Logical Seek is completed, you are prompted to "Input Media Length".

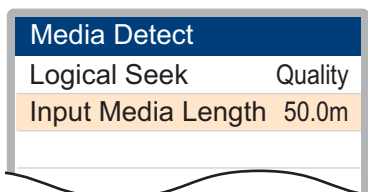

- When you set "Media remaining amount display" of the machine setting to "OFF", this screen is not displayed. (P.3-15)

- 2 Press to enter the media remaining amount.

- 3 Press the key.

Detecting media width when media detection method is "MANUAL"

- 1 Press to select a media (roll or leaf).

- The media detection screen appears.

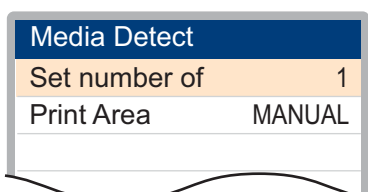

- 2 Press to enter the number of mounted media, and press the key.

- 3 Select and press the key.

- The "RIGHT EDGE POSITION" screen will be displayed.

- 4 Press to move the head, align the LED pointer to the right edge of the media and press the key.

- The "LEFT EDGE POSITION" screen will be displayed.

- 5 In the same way as in step 4, decide the left edge position of the media and press the key.

- Media width is set.

- When the media detection is completed, the screen of "Setting a roll media as described in step 21 is displayed. Follow the steps 22 and later.

Use the image quality confirmation LED light to check the print

On the front of this unit, it has a quality confirmation LED light to check the print by shedding the light from the back side of the media (back light).

Before using the image quality confirmation LED light

Important!

- Please ensure the power cable of the image quality confirmation LED light is connected to the AC outlet on the right side of machine.
- Make sure that the power switch of the image quality confirmation LED light is ON.

Use the image quality confirmation LED light



You can adjust the light intensity of the image quality confirmation LED light to suit the position of the image to be printed.

- Two LED panels are available for image quality confirmation: one on the right and the other on the left.
- You can adjust the light intensity of each panel by using the light intensity adjustment dial located on the upper section of the panel. Because the light intensity adjustment dial is provided on both the right and left panels, you can separately adjust the light intensity for the panels located on the right and left.

LED lights change-over switch

Use this switch to select the light intensity adjustment dial you want to use, either the one on the left panel or the one on the right panel.

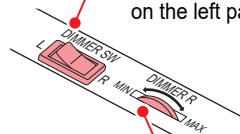

Light intensity adjustment dial

Adjust the amount of light on the LED light.

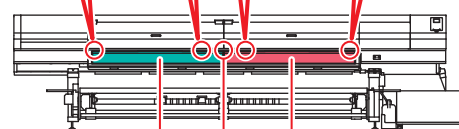

Left side LED panel Right side LED panel

LED panel connection cable

By connecting the right and left of the LED panel, supply the power to the left side of the panel.

Remove and use the image quality confirmation LED light

Image quality confirmation LED light is removable. Please use when check the finish of the printed matter on work table and the like.

- (1) Turn off the power of the image quality confirmation LED light and unplug.
 - Outlet for the image quality confirmation LED light is connected to the right side of the machine.

Power switch

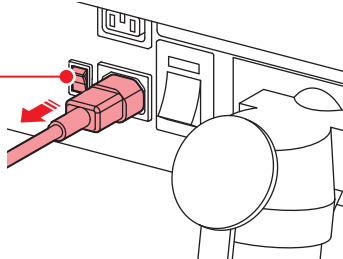

- (2) Remove the AC adapter.
 - Peel off the magic tape that secures the AC adapter, then remove the AC adapter.

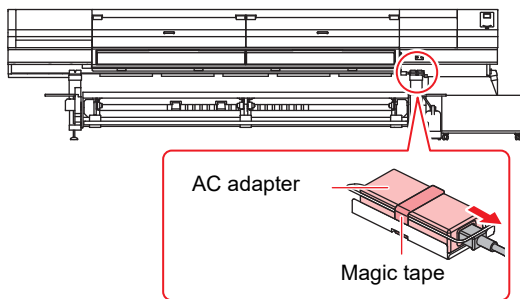

- (3) Remove the LED holder by sliding it, and pulling to the front side.

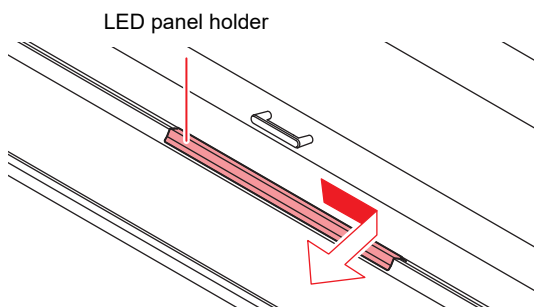

- (4) Tilt the LED panel on the front.

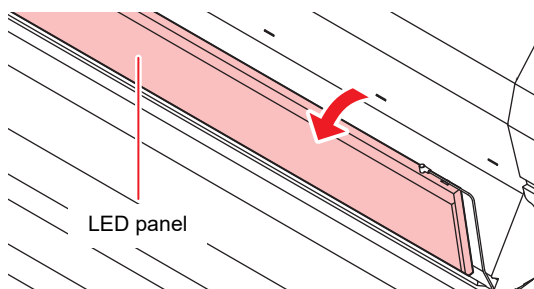

- (5) Remove the LED panel connection cable.



- Do not remove the LED panel while it is still connecting the connecting cable. Panel may fall and will be the cause of damage.

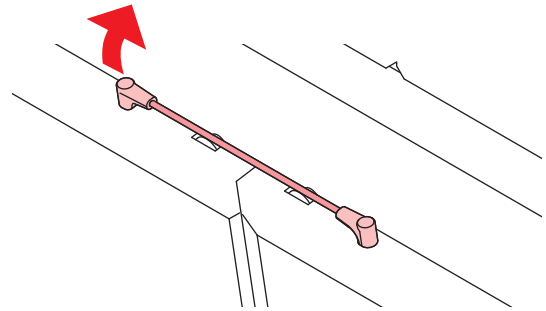

- (6) Removing the image quality confirmation LED light.

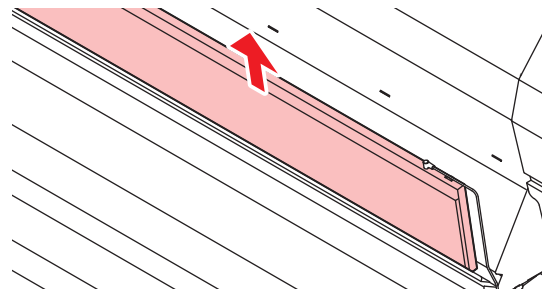

- (7) Place on the work table with the LED light side to the top and check the print.

Setting a narrow roll media

When you use narrow roll media (up to 1.6m), set the media on the narrow roll holder.

Important!

- At the take-up side, set the printed surface to “involute”. (If you set it to “revolute”, it may adversely affect the media feeding.)
- When setting a media, place the media in the center of the machine. If the media is set to the right or left, the media may not be transported normally.

1 Set the setting of the feeding unit to “OFF” in “Setting Feeding unit” of the machine setting. (P.3-14)

2 Open the front cover and rear cover.

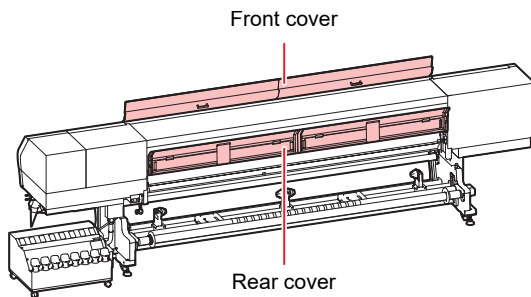

3 Move the media press to outside.

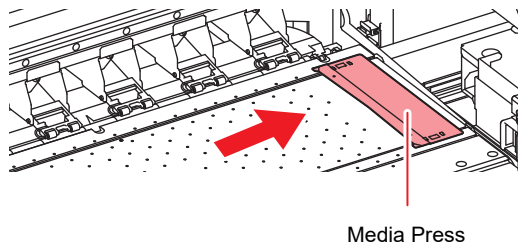

4 Move the roll holder R on the back of this machine.

- Loosen the roll holder fixing screw and then move it.
- Move the roll holder to such a position that the media will be set in the center of this machine.



- The roll holder guide shaft has a mark indicating the center position. Refer to this mark when setting.

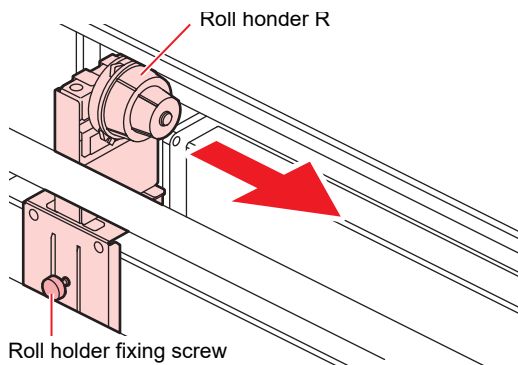

5 Tighten the fixing screw of roll holder R.

6 Set the roll tables as shown in the figure and temporarily place the media on top of the tables.

- Keep a proper space between the tables to stabilize the media.

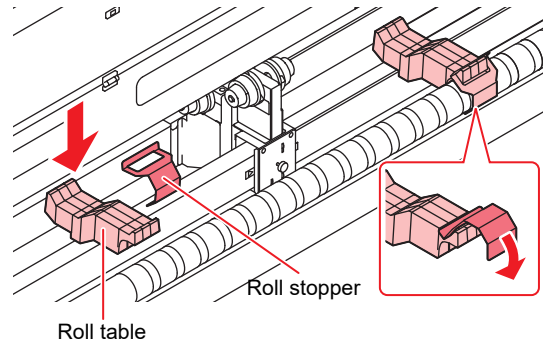

- If it is difficult to directly set the media in the roll holders, temporarily set on the roll tables and then set the roll holders to make setting easier.

7 Insert the paper core into the roll holder R.

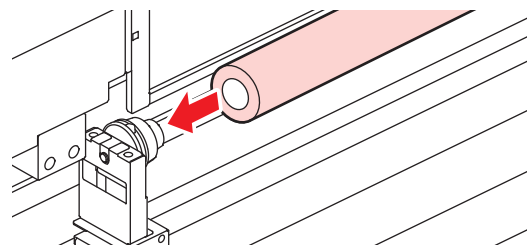

8 Loosen the screw of the roll holder C then insert the holder into the core of the roll media.

- Push the roll media onto the roll holder until the roll core is all the way seated.

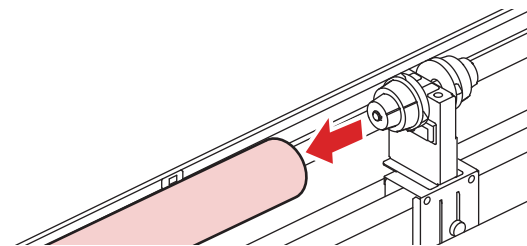

9 Remove the roll tables

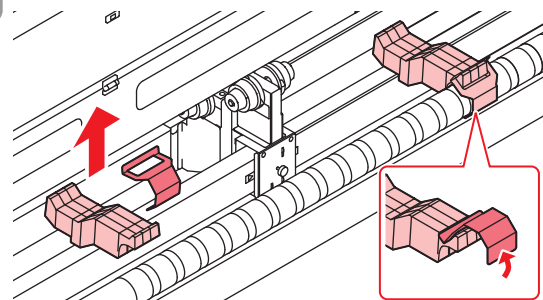

- 10** Raise the clamp lever in the rear side of this machine.

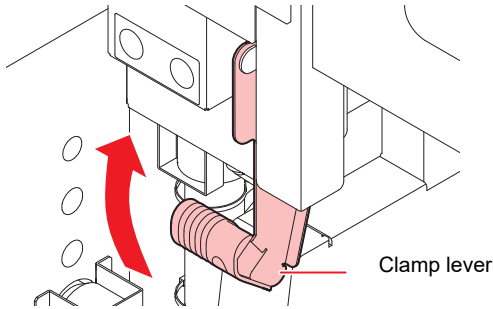

- 11** Insert the roll media in this machine.

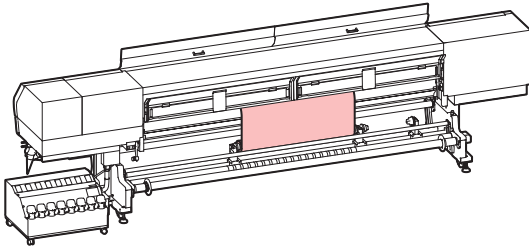

- Insert the media from the end first so that there is little catching and the media can be inserted smoothly.

- (1) Pull the media out of the roll to the head of the platen.
- (2) Insert the media between the platen and the pinch roller.
 - Pull the media out of the roll so that the media can be grasped from the front of the machine.
- (3) Push down the clamp lever from the back of this machine.
 - The media is held.

- 12** Close the rear cover.

- 13** Pull out the roll media out.

- (1) Raise the clamp lever from the front of this machine.
- (2) Pull out the roll media gently.

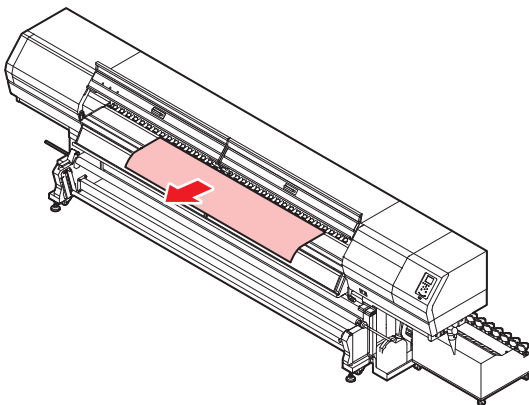

- 14** Push down the clamp lever from the front of this machine.

- 15** Hold the media with the media press gently.

- Set the media so that no media sticks out from the right end pinch roller to the right side.
- When using a thick media, remove the media press from the media before printing.

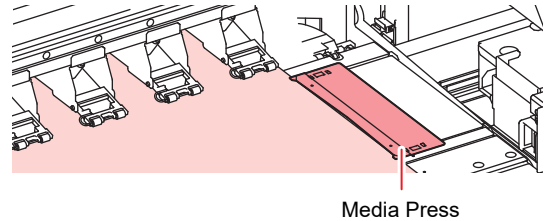

- 16** Prepare for the take-up device.

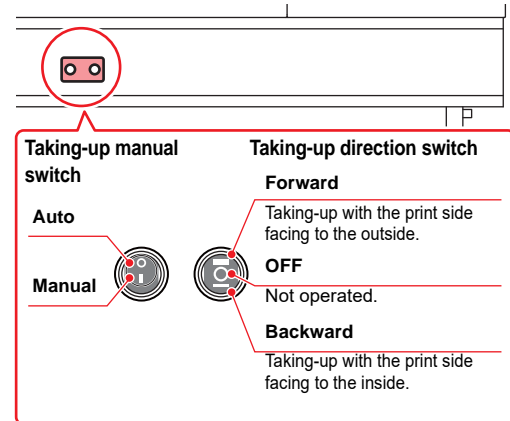

- (1) Set the taking-up direction switch to "OFF" (Center)
- (2) Set the taking-up manual switch to "Auto" (Lower)

- 17** Raise the tension bar on the front side to the highest position, and lock the bar.

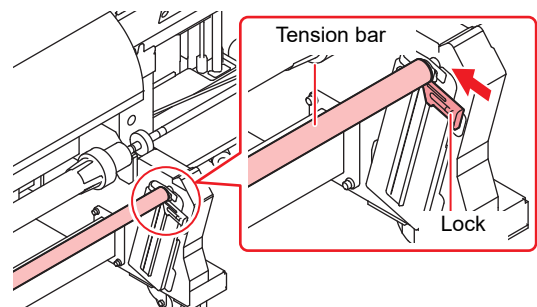

18 Feed the media to the tension bar.

- (1) Pressing the [▼] key, feed the media until the tension bar at the rolling side is being hidden.
 - Check the media end is not caught into the slot on the platen, and feed the media.

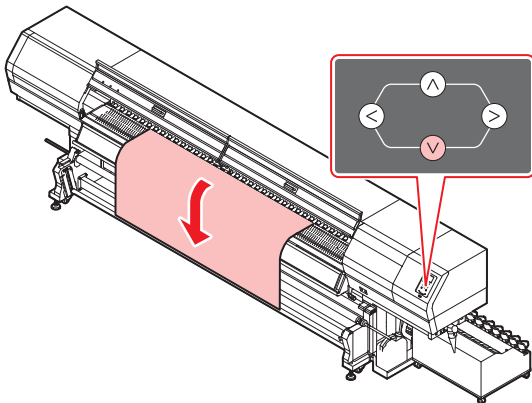

19 Fix the media to the roll shaft.

- (1) Route the media from the front side of the tension bar, and fix the media in the center of the roll shaft with adhesive tape.

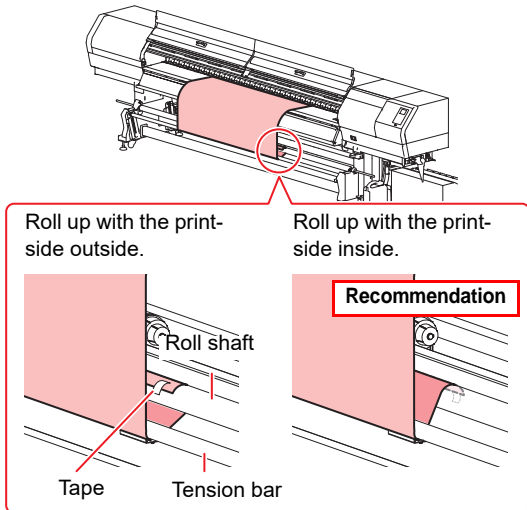

- (2) In the same manner, fix the left side and right side of the media.
 - Pull roll media evenly for right and left, check that there is no slack or waviness on the media, and paste tape in numerical order.
 - When you place the tape, consider the rolling-up direction.

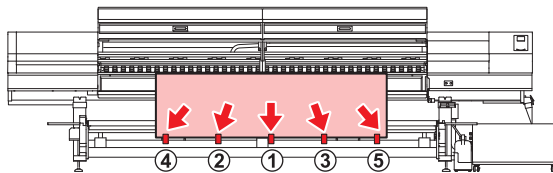

20 Press [▼] to feed the media about 10 cm, and then release the lock of the tension bar.

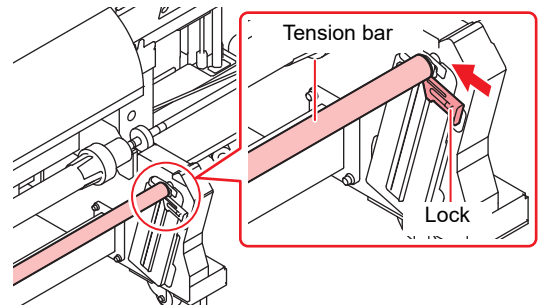

21 Roll up the media.

- (1) Set the taking-up direction switch to "Forward"/ "Backward" according to the taking-up method.
- (2) Press [▼], and rotate the roll shaft 2-3 times to take up the media.
- (3) Press the [ENTER] key.

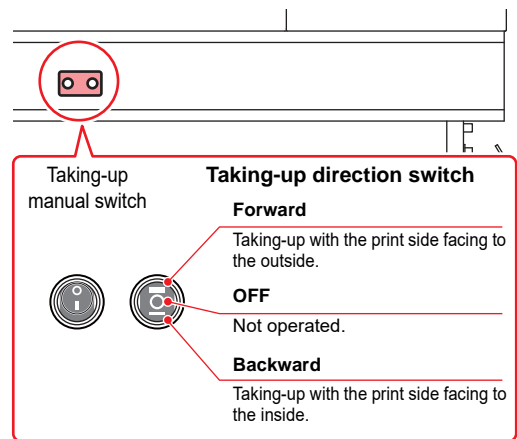

- **To take up the media with its print-side facing inside:**
Set the taking-up direction switch to "Backward".
- **To take up the media with its print-side facing outside:**
Set the taking-up direction switch to "Forward".
- **To stop taking-up:**
Set the taking-up direction switch to neutral (OFF).

22 Hold the media with the media press gently.

- Set the media so that no media sticks out from the right end pinch roller to the right side.
- When using a thick media, remove the media press from the media before printing.

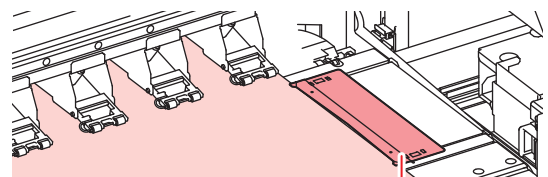

23 Close the front cover.

24 Press the  key to select "ROLL".

- If the [Setting the Display of Media Detection] of Machine Setup set in "AUTO" (P.3-16), the machine automatically detects the media width.

25 Setting the Logical Seek.

(1) Press [▲][▼] to select the set value.

- Set value : Media/ Data/ Quality

(2) Press the [ENTER] key.

- When [Media Remain] of the Machine Setup is "ON" (P.3-15), you are prompted to enter the media remaining amount. (P.2-10)

Important!

- Before printing, rewind by hand the roll media set on the narrow roll holder to remove any slack. If the media is loose, the media feed amount varies, causing poor image quality.
- When you do not use the take-up device, feed the media until the media reaches the floor, and then print. If you print with the media out of contact with the floor, the media feed amount varies during printing, causing poor printing quality.



- Surface waviness or ruck may affect the quality of currently printed image. When fixing media with tape, align the media along the direction indicated with an arrow in the figure.
- If you pull the media too much when fixing with tape, the media tension may not be even. And, it may negatively affect the media feeding.

Setting two narrow roll media (twin rolls)

Important!

Pay attention to the following when printing on twin rolls.

- Use media having a media width of 1524 mm or less and a paper core width of 1550 mm or less.
- Set two media having the same properties as shown below. Otherwise, the printed image quality will be affected.

Media type, media grade, media width, the diameter of media to be set (with the same remaining media amount), and media rolling-up direction

1 Set the settings of "Feeding Unit" and "Take-up Unit" of the Machine Setup to OFF.

- Refer to P.3-14 "Setting Feeding unit" and P.3-14 "Setting Take-up unit".

2 Open the front cover and rear cover.

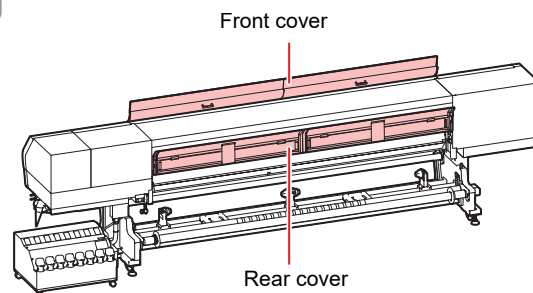

3 Rise the clamp lever.

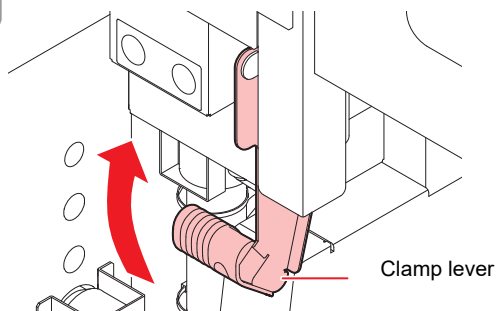

4 Add the attached media press to hold the two media.

(1) Remove the left side maintenance cover.

- Rotate the screws under the left side maintenance cover (for three positions) to the left and remove them.
- Hold the bottom of the left maintenance cover, and pull the cover toward you from below to remove the cover.
- If the left side maintenance cover is hard to remove, use the supplied screwdriver.

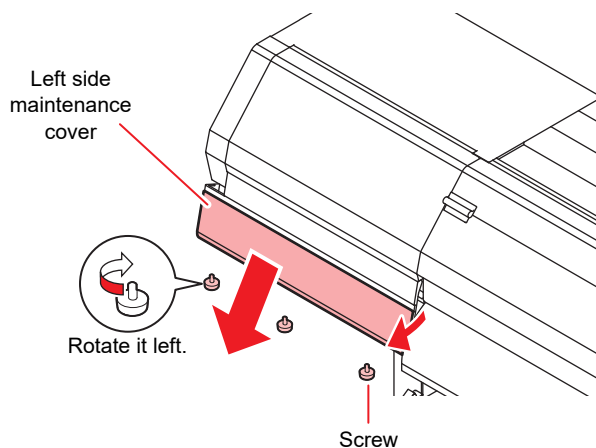

(2) Attach the Media press in the accessories.

- Fit the protruding portion of the media press into the groove of the platen (circle part in the figure below).

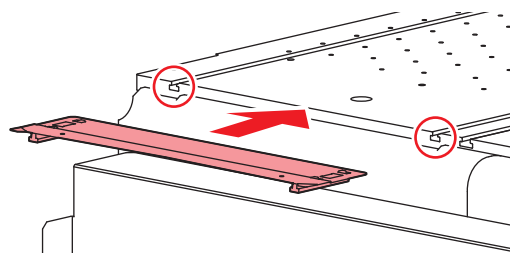



- There is a direction to the media press. Please install the left and right properly.

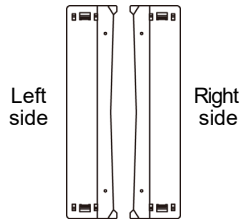

- (3) Return the sheet metal that was removed in step (1) to the original position and attach the left side maintenance cover.

5

Move the roll holder C to the center of this machine, and the roller holders R and L to the right and left ends of this machine respectively.

- Follow the steps below to move the roll holders.

- (1) Loosen the roll holder fixing screw.

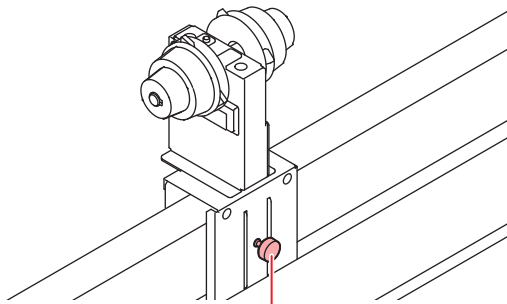

Roll holder fixing screw

- (2) Move the roll holders R, and L to the right, and left of this machine respectively.

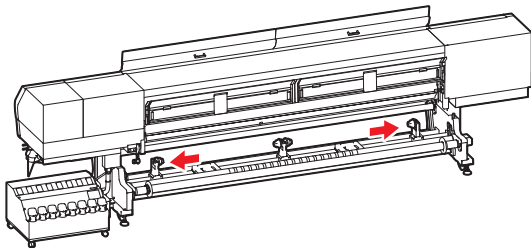

- (3) Move the roll holders C to the center of this machine, and tighten the fixing screw of roll holder C.

- This machine has a mark indicating its central position to allow the roll holder C to be set.
- Tighten the screw firmly to secure the roll holder C at its proper position.

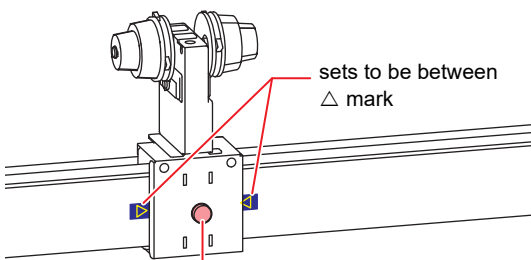

sets to be between Δ mark

Roll holder fixing screw

6

Set media in the roll holder.

- Set the media one by one.

- (1) Set the roll tables as shown in the figure and temporarily place the media on top of the tables.

- Keep a proper space between the tables to stabilize the media.

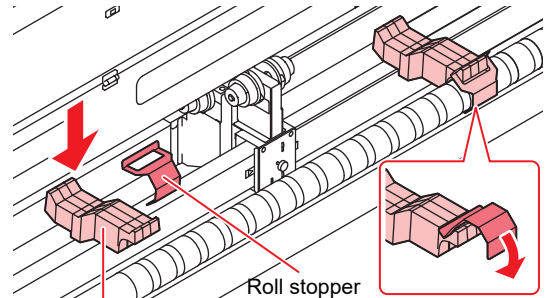

Roll table

- (2) Insert the paper core of the media into the roll holder C.

- Push the roll media onto the roll holder until the roll core is all the way seated.

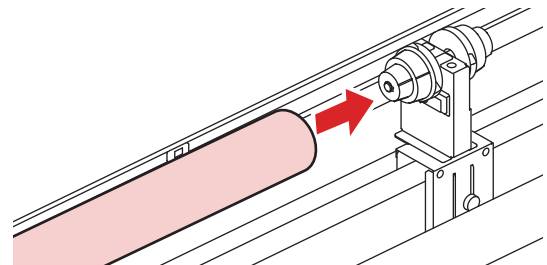

- (3) Insert the roll holder R (or L) into the paper core, and tighten the fixing screw.

- Tighten the screw so firmly that the roll holder will not move during printing.

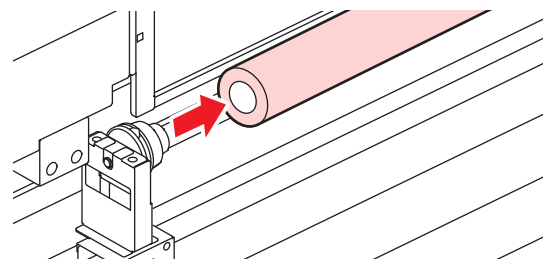

- (4) Remove the roll tables, and move the tables to allow the other media to be set.

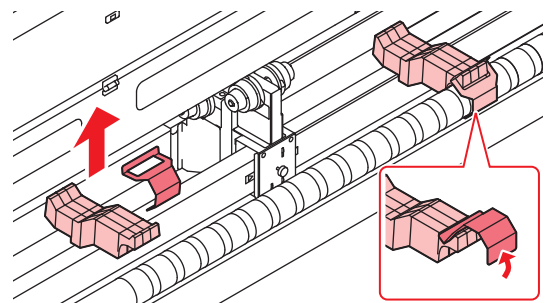

- (5) Set the other media in the same way as described in steps (2) and (3).

- (6) Remove the roll tables and store the tables.

7 Raise the clamp lever in the rear side of this machine and Insert the roll media.

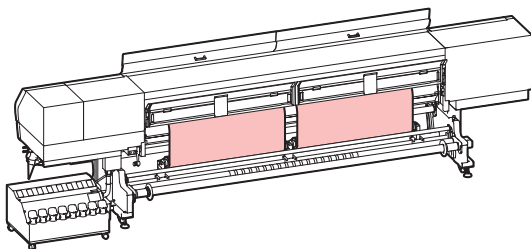

- The roll media can be smoothly inserted by slanting the media.

(1) Pull the media out of the roll to the head of the platen.

(2) Insert the media between the platen and the pinch roller.

- Pull the media out of the roll so that the media can be grasped from the front of the machine.

(3) Push down the clamp lever .

- The media is held.



- When setting media, check that the two media sensors located near the center of the preheater cover are individually covered over by the respective media. If one media covers the two sensors, or if there is a media covering neither of the media sensors, the media width is not detected properly, causing damage to this machine.

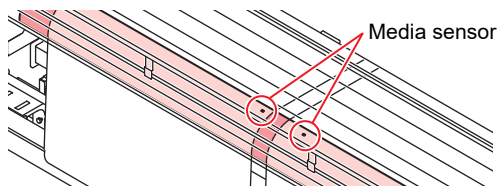

8 Close the rear cover.

9 Pull out the roll media out.

(1) Raise the clamp lever from the front of this machine.

(2) Pull out the roll media gently.

- Pull out the two media until both media reach the floor.

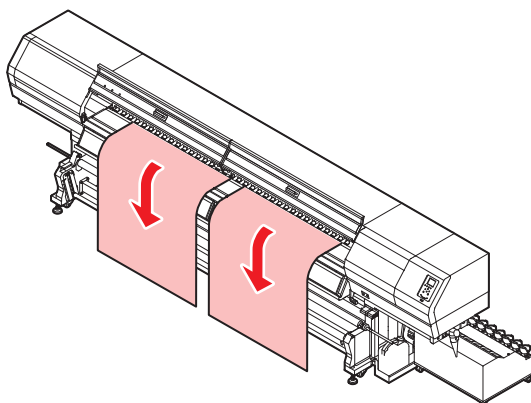

10 Push down the clamp lever.

- Check that the roll media are drawn out almost evenly by lightly pulling several points of the media, and then lower the clamp lever.
- Check that the tension applied to the media is equal for both the left and right sides.

11 Hold the media with the media press gently.

- When using a thick media, remove the media press from the media before printing.

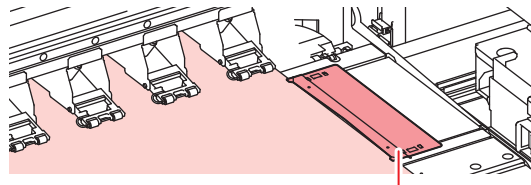

Media Press



- If any of the media is located right or left of its specified position after media detection, a message appears, indicating that the media is located too right or left. Set the media again.

12 Close the front cover.





- Do not secure either media on the take-up device when printing on twin rolls.
- Before printing, check that the media has no slack. Rewind any loose roll media.

13 Press the key to select "ROLL" .



- If the [Setting the Display of Media Detection] of Machine Setup set in "AUTO" ( P.3-16), the machine automatically detects the media width.

14 Setting the Logical Seek.

(1) Press [][] to select the set value.

- Set value : Media/ Data/ Quality

(2) Press the [ENTER] key.

- When [Media Remain] of the Machine Setup is "ON" ( P.3-15), you are prompted to enter the media remaining amount. ( P.2-10)

Setting media by using the narrow take-up device

If you are using PVC or photo paper as the media, take up the media set in the roll holder by using the narrow take-up device, as described below.

Important! You have to complete the following steps before taking up the media by using the narrow take-up device.

- (1) Set "Setting Feeding unit" and "Setting Take-up unit" of Machine Setup to "OFF".
- (2) Lower the tension bar located on the front of the machine to its lowest position.
- (3) Remove the roll shaft that is used to take up wide media.

Set the settings of Feeding unit and Take-up unit of Machine Setup to "OFF"

1 By referring to P.3-14, set the settings of Feeding unit and Take-up unit to "OFF".

Important! If you do not set the settings of Feeding unit and Take-up unit to "OFF", the narrow take-up device might not be able to take up the printed media.

Lower the tension bar located on the front of the machine to its lowest position to remove the roll shaft

You have to complete the steps described below before using the narrow take-up device. Failure to do so could cause machine damage.

1 Lower the tension bar located on the front of the machine to its lowest position.

(1) Unlock the tension bar.

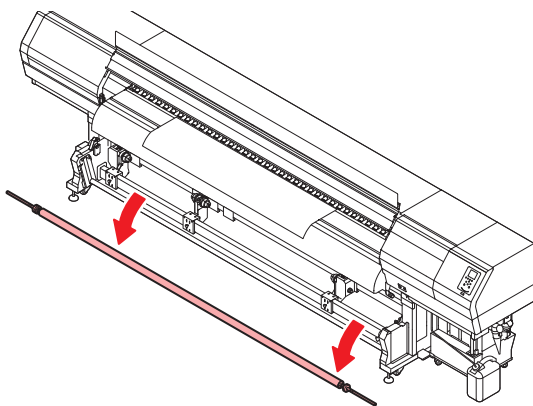

(2) Lower the tension bar to its lowest position, and then lock it.

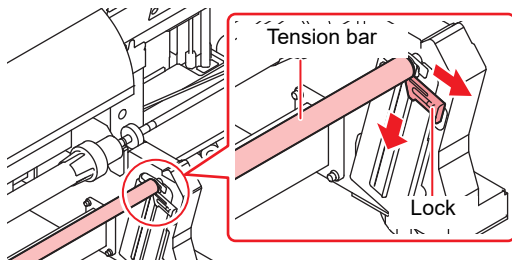

Set media by using the narrow take-up device

1 To use the narrow take-up device, you must first complete the following two steps:

- "Adjusting the Head Height and Jam sensor Height"
- "Note for media setting"

2 Follow the steps 2 to 15 of "Setting a narrow roll media". (P.2-12)

3 Feed the media to the narrow take-up device.

- (1) Pressing [▼], feed the media until the paper core of the narrow take-up device is hidden.
 - Check the media end is not caught into the slot on the platen, and feed the media.

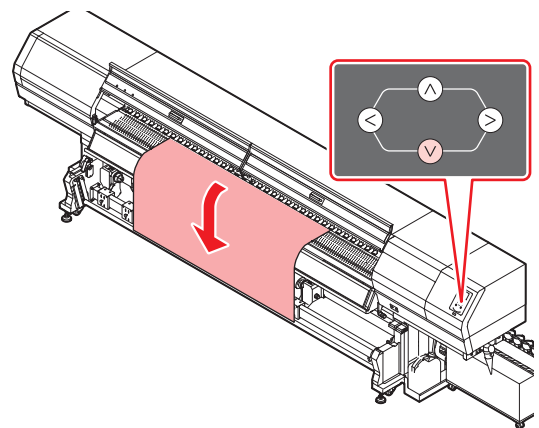

4 Fix the media to the paper core.

- (1) Fix the media in the center of the paper core with adhesive tape.

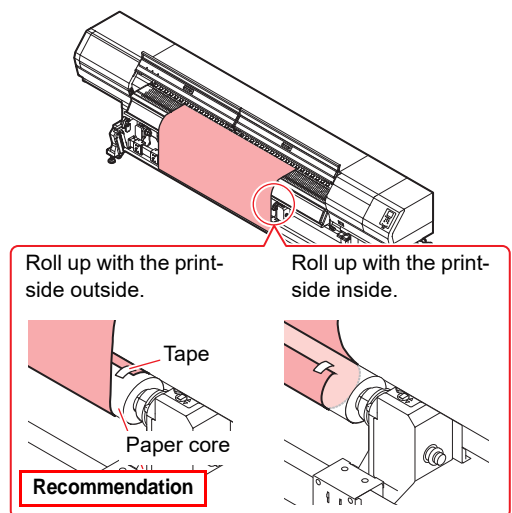

Important! With the narrow take-up device, the media is routed as shown in the figure to the right. No tension bar is used.

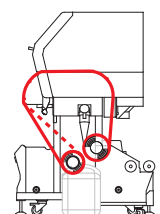

(2) In the same manner, fix the left side and right side of the media.

- Pull roll media evenly for right and left, check that there is no slack or waviness on the media, and paste tape in numerical order.
- When you place the tape, consider the rolling-up direction.

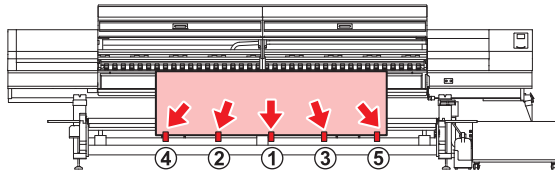

5 Roll up the media.

- By using the switch and the button on the narrow take-up device, select a media taking-up direction and then take up the media.

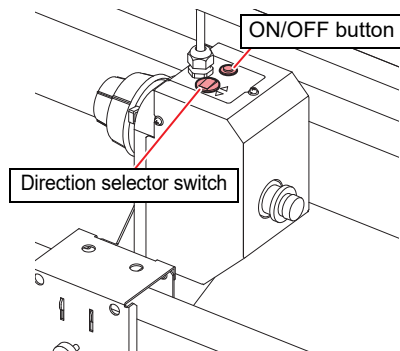

Direction selector switch	Front side (FORWARD)	The take-up device winds the media with the printed side facing in.
	Rear side (REVERSE)	The take-up device winds the media with the printed side facing out.
ON/OFF button		Turns the winding motion on/off. (When you press the button and operate the take-up device, the device keeps taking up the media until you press the button again. *1)

*1. You can also change the setting so that the taking-up operation only lasts while the ON/OFF button is being pressed. For details, refer to "Setting Take-up unit" in machine settings.

6 Follow the steps 22 and later of "Setting a narrow roll media". (P.2-12)

Set media by using the narrow take-up device (twin rolls)

Important!

Pay attention to the following when printing on twin rolls.

- Use media having a media width of 1524 mm or less and a paper core width of 1550 mm or less.
- Set two media having the same properties as shown below. Otherwise, the printed image quality will be affected.

Media type, media grade, media width, the diameter of media to be set (with the same remaining media amount), and media rolling-up direction

1 To use the narrow take-up device, you must first complete the following two steps:

- "Adjusting the Head Height and Jam sensor Height"
- "Note for media setting"

2 Follow the steps 2 to 11 of "Setting two narrow roll media (twin rolls)". (P.2-15)

3 Feed the media to the narrow take-up device.

- (1) Pressing [▼], feed the media until the paper core of the narrow take-up device is hidden.
- Check the media end is not caught into the slot on the platen, and feed the media.

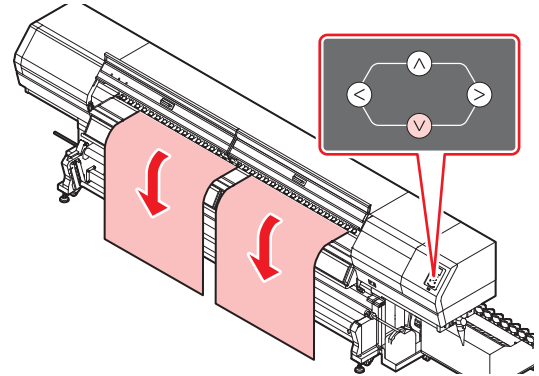

4 Fix the media to the paper core.

- (1) Fix the media in the center of the paper core with adhesive tape.

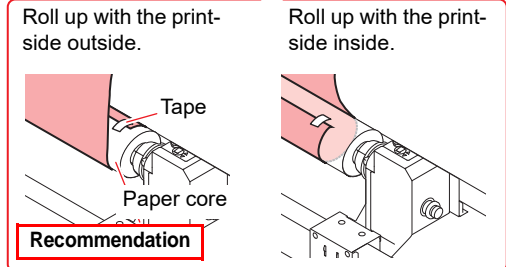
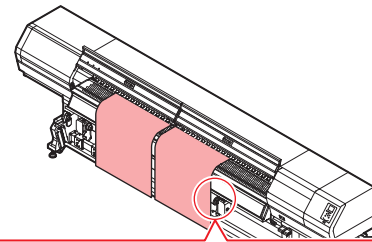

Important!

- With the narrow take-up device, the media is routed as shown in the figure to the right. No tension bar is used.

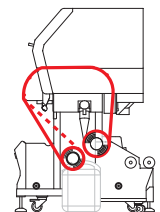

(2) In the same manner, fix the left side and right side of the media.

- Pull roll media evenly for right and left, check that there is no slack or waviness on the media, and paste tape in numerical order.
- When you place the tape, consider the rolling-up direction.

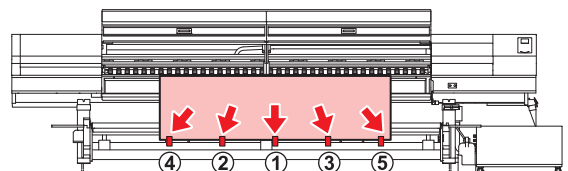

2

5 Roll up the media.

- By using the switch and the button on the narrow take-up device, select a media taking-up direction and then take up the media.

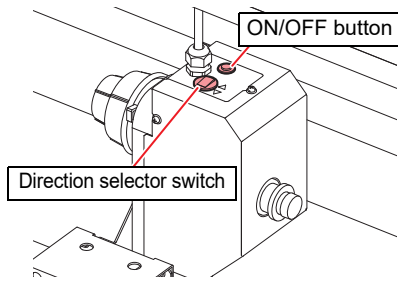

Direction selector switch	Front side (FORWARD)	The take-up device winds the media with the printed side facing in.
	Rear side (REVERSE)	The take-up device winds the media with the printed side facing out.
ON/OFF button		Turns the winding motion on/off. (When you press the button and operate the take-up device, the device keeps taking up the media until you press the button again. *1)

*1. You can also change the setting so that the taking-up operation only lasts while the ON/OFF button is being pressed. For details, refer to "Setting Take-up unit" in machine settings.

6 Follow the steps 13 and later of "Setting two narrow roll media (twin rolls)".
(☞ P.2-15)

Setting leaf media

Unlike roll media, leaf media does not need to be retained with the roll holders.

1 Open the front cover and raise the clamp lever.

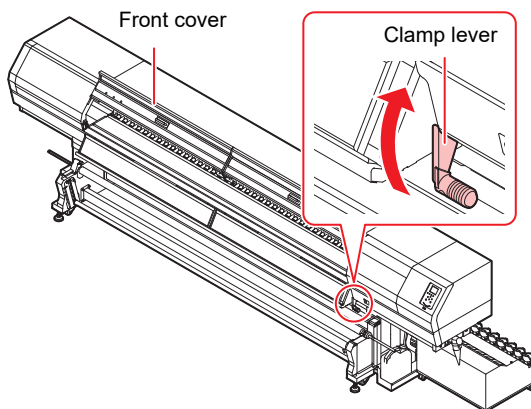

2 Insert the leaf media between the platen and the pinch rollers.

- Set the media so that no media sticks out from the right end pinch roller to the right side.

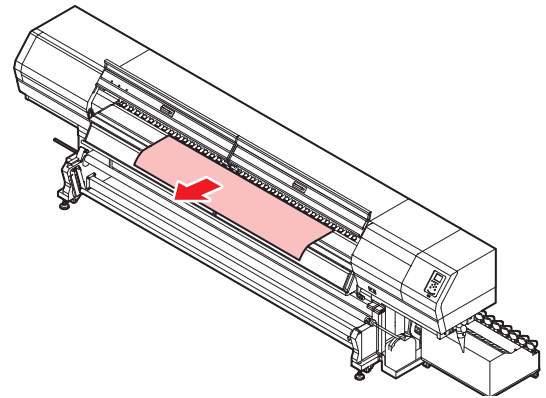

3 Hold the media with the media press gently.

- Set the media so that no media sticks out from the right end pinch roller to the right side.
- When using a thick media, remove the media press from the media before printing.

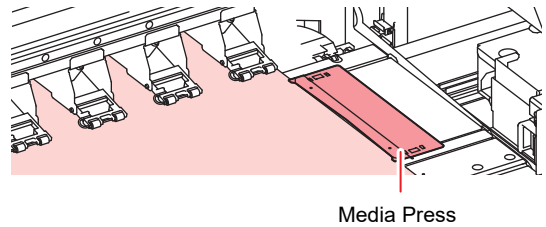

4 Push down the clamp lever and close the front cover.

- Set the media straight.

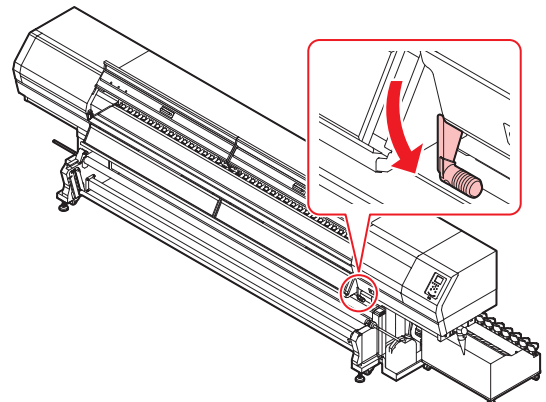

5 Press the **ENTER key.**

6 Press the **▶ key to select "LEAF".**

- If the [Setting the Display of Media Detection] of Machine Setup set in "AUTO" (☞ P.3-16), the machine automatically detects the media width.

7 Setting the Logical Seek.

(1) Press [▲][▼] to select the set value.

- Set value : Media/ Data/ Quality

(2) Press the [ENTER] key.

- When [Media Remain] of the Machine Setup is "ON" (☞ P.3-15), you are prompted to enter the media remaining amount. (☞ P.2-10)

Removing the taken-up media

1 Release the lock of the taking-up tension bar and lower the tension bar.

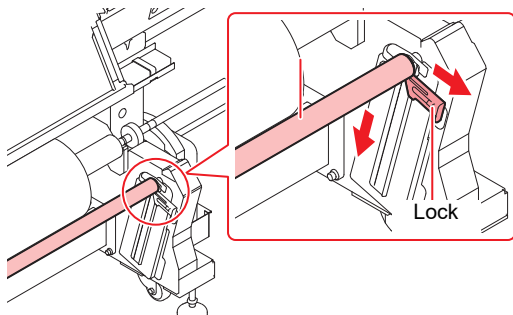

2 Open the cover on the left side of the taking-up shaft and pull the taking-up shaft forward.

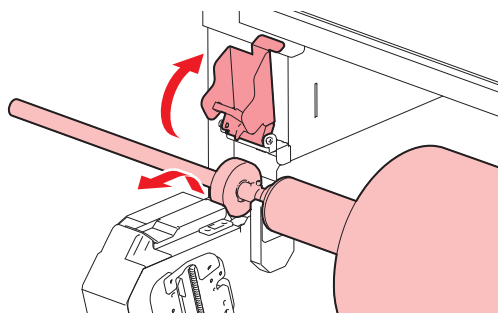

3 Pull out so that the white plastic collar is inserted into the slot on top of the leg.

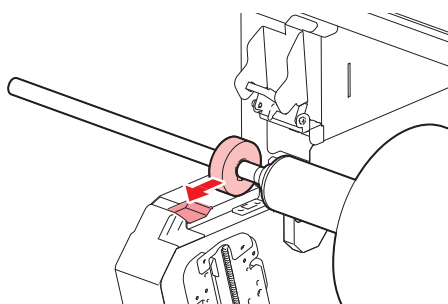

4 Remove the roll holder, and take off the paper core.

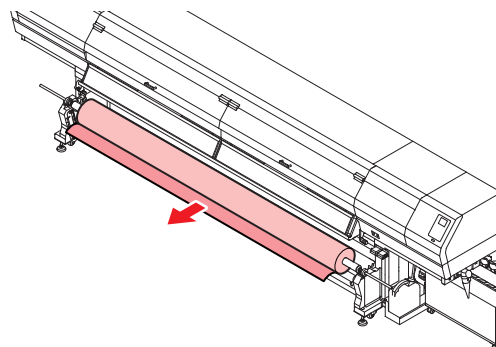

Changing the printing origin

The position of the printing origin can be changed.

1 In Local, press ▲▼◀▶.

- It enters into the origin setting mode.

Origin Setup	
X	Y
0.0	0.0

2 Press ▲▼◀▶ to set the origin to a desired position.

Origin Setup	
X	Y
0.0	0.5
Origin (Length)	Origin (Width)

- Select the carriage and media, moving the point with [▲][▼][◀][▶]. (Position of the LED pointer becomes the origin position.)

3 After determining the origin, press the [ENTER] key.

- The printing origin is changed.

Important!

- When a roll media is set on the narrow roll holder, change the origin, and then rewind the media by hand and set the media without slack. If the media is loose, the media feed amount of the media varies, causing poor image quality.

2

Preparing for the Heaters

Changing the Temperature Settings for the Heaters

Set the heater temperature.

Depending on the media and the profile to use, set the heater temperature.

- It may take several minutes to tens of minutes for the set temperature to be reached, depending on the ambient temperature.



- You can change the temperature set here also in [Heater] of the [Setup] menu. (☞ P.3-6)

1

Press the **SEL** key, and then press the **FUNC2** (Heater) in LOCAL.

- The heater temperature adjustment screen appears.

2

Press **▲** **▼** to set the temperature of heater.

Temperature setting: Set with **▲** **▼**

- The heater starts to get hot.

3

The heating of the heater stops.

- When the heater temperature reaches the set temperature, the heater icon lights in green.

4

Press the **ENTER** key to stop heating.

- The screen returns to LOCAL.



- The Heater temperature is controllable at the RIP side if the RIP in use has a function controllable. (For the setting procedures, refer to the instruction manual of the RIP in use.)

Important!

- Use this machine under 20 to 30°C. The temperature may not reach the set value due to the environmental temperature condition.

Test Printing

Print a test pattern to check that there are no discharging defects such as nozzle missing (slight touching of ink or nozzle missing).

Relationship between head row and test pattern

The relations between head row and test pattern print position are as follow.

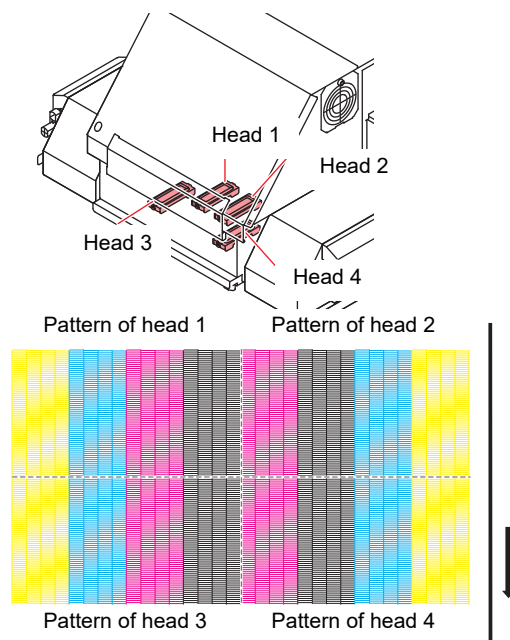

Note on test printing

Important!

- When using leaf media, set a media of more than 210mm put horizontally. If a media with narrow width is set, printing will only be conducted to midway.
- If use by setting the media to Narrow roll holder, rewind the media by hand before printing so that it is not loose. When the roll media has not been rewound tightly, it may cause image quality to deteriorate.
- When test print, be sure to close all the covers (front cover / rear cover).

Test Printing

Print a test pattern to check that there are no discharging defects such as nozzle missing (slight touching of ink or nozzle missing).

In addition, you can select the orientation of the test pattern to print from two types in order to perform test printing repeatedly. Select one depending on your use.

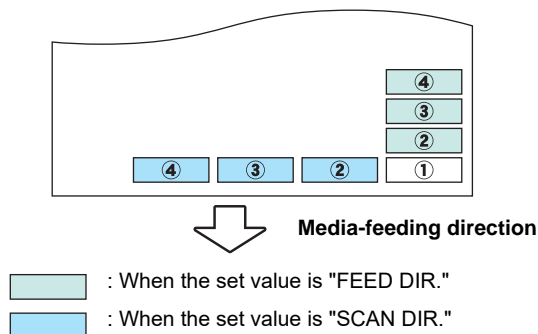

Check before test printing.

- If a media has been set (P.2-4)
- If the origin position has been set
- If the head gap has been adjusted (P.2-4)

1 Press the **FUNC2** (TEST PRINT/CLEANING), and press the **ENTER** key in LOCAL.

- TEST PRINT MENU appears.
- Press **[▲][▼]** to change the test pattern orientation. The orientation selected here will be reflected on when you will print next time.
- When performing test printing after having changed the orientation from "SCAN DIR." to "FEED DIR.", the line is fed to the position of the first test printing.

2 Press the **ENTER** key.

- Test printing starts.
- When the printing has been completed, the screen returns to LOCAL.

3 Check the printed test pattern.

- When the result is normal, end the operation.
- When the result is abnormal, perform head cleaning. (P.2-23)

Normal pattern

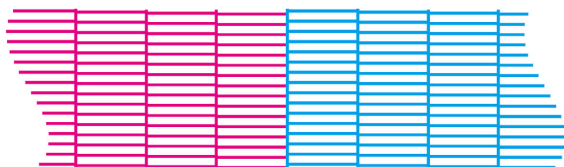

Abnormal pattern

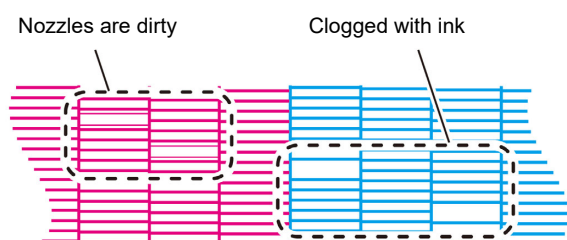

Head Cleaning

About head cleaning

Check the printed test pattern result and perform cleaning depending on the status.

Select one from the three types below:

- Soft** : When lines are bent, when any line is missing
- Normal** : When any line is missing, when colors are mixed
- Hard** : When poor image quality cannot be improved even by Normal or Soft cleaning

Perform head cleaning depending on the test printing result

There are three types of head cleaning. Use one by checking the test pattern.

1 Press the **FUNC2** (TEST PRINT/CLEANING), and press the **ENTER** key in LOCAL.

2 Press **▲▼** to select "CLEANING", and press the **ENTER** key.

- CLEANING MENU appears.

3 Press **▲▼** to select the cleaning type.

- **Soft** : When lines are bent, when any line is missing
- **Normal** : When any line is missing, when colors are mixed
- **Hard** : When poor image quality cannot be improved even by Normal or Soft cleaning

4 Press the **ENTER** key.

5 Press **▲▼** to select the cleaning head, and press the **FUNC2** (✓).

- After selecting the head, press the **[FUNC2]** key and put a check in the check box. The head whose box has been checked will be cleaned.
- To have all head cleaned, put a check in all check boxes.

6 Press the **ENTER** key.

7 Perform test printing again, and check the result.

- Repeat the cleaning and the test printing until the drawing result becomes in normal.



When the image quality is not improved after the head cleaning.

- Clean the wiper and ink cap. (P.4-7)
- Wash the head nozzle. (P.4-13)

Setting of Media Correction

Correct the media feed amount to match the type of media you are using.

If the correction value is not appropriate, stripes may appear on the printed image, thus resulting in a poor printing.



- Be sure to perform feed correction each time before printing. The media feed amount may vary, depending on the remaining amount of the roll media.
- If use by setting the media to Narrow roll holder, rewind the roll media by hand and set without slack. There may not be accurate to correct the feed amount.
- On completion of [MEDIA COMP.] during use of a roll media, the media returns to the printing origin. When a roll media is set on the narrow roll holder, Slack will occur in the roll media of the back side of this machine. Before printing, take up the slack in the roll media by hand; a loose roll media can result in an inferior image quality.
- When printing with a take-up device, set the media first and then perform media correction.
- If print without using the take-up device, please make the correction from sending media to reach the floor. There is a possibility that the fed amount can not be adjusted normally.

Setting of Media Correction

A pattern for media correction is printed and a media-feeding rate is corrected.



- Two bands are printed in the correction pattern.
- Make adjustment so that an even color density is obtained in the boundary between the two bands.

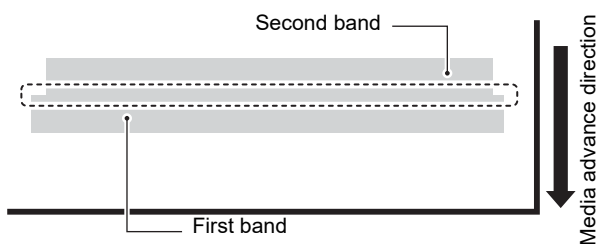

1

Set a media. (☞ P.2-4)

2

Press the **[SEL]** key, and press the **[FUNC1]** (ADJUST) in LOCAL.

- ADJUST MENU appears.

3

Press the **[ENTER]** key.

4

Press **[▲]****[▼]** to enter resolution.

- Here enter the resolution in the scanning direction (Y direction) of the media.



- Enter a resolution matching the data printed usually. This machine changes the media feeding method, depending on the resolution. If you enter a resolution inconsistent with actual printing, it may result in an inappropriate feed amount.

5

Press the **[ENTER]** key twice to print the correction pattern.

6

Check the correction pattern and enter a correction value.

- A screen for entering the correction value appears.
- Enter a correction value in "+":
The boundary between the two bands is widened.
- Enter a correction value in "-":
The boundary between the two bands is narrowed.
- When you change the correction value by "30", the width of the boundary changes by about 0.1 mm.

7

Press the **[END/POWER]** key several times to end the setting.



- You can select "Feed Comp." by using the [FUNCTION] key in the Local without pressing the [FUNC2] (ADJUST) key. (☞ P.3-5)

Correcting Media-feeding during Printing

A media-feeding rate can be corrected even in the remote mode or when image data is printed.

1

Press the **[FUNC1]** (ADJUST) in the Remote.

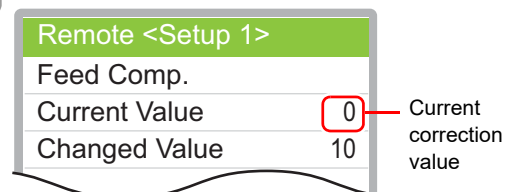

2

Press **[▲]****[▼]** to enter a corrected feeding rate.

- Corrected feeding rate: -9999 to 9999
- The value entered here is reflected in the corrected feeding rate soon.

3

Press the **[ENTER]** key.

- The changed value is registered.
- When you press the [ENTER] key instead of the [END/POWER] key, the value entered here will be invalid.

4

Press the **[END/POWER]** key several times to end the setting.

Correct the ink drop position for bidirectional printing

When the condition for printing (media thickness/ink type/etc.) has been changed, perform the following operation to correct the ink drop position for bidirectional (Bi) printing and obtain the proper printing result.

- Important!**
- When using leaf media, set a media of more than 210mm put horizontally. If a media with narrow width is set, printing will only be conducted to midway.

Example of a Printed Pattern

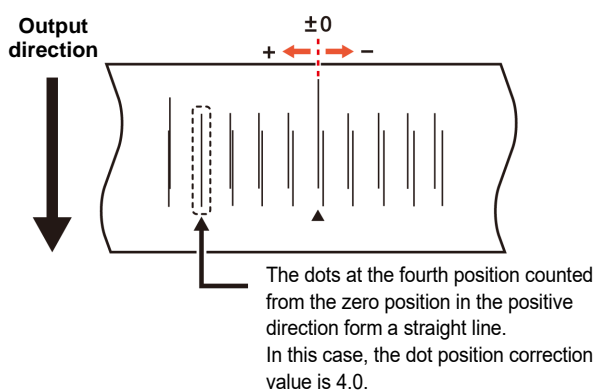

- 1** Set a media on the machine and set a printing origin. (☞ P.2-4)
- 2** Press the **SEL** key, and press the **FUNC1 (ADJUST)** in LOCAL.
 - ADJUST MENU appears.
- 3** Press **▲▼** to select "DROP.POScorrect".", and press the **ENTER** key.
- 4** Press **▲▼** to select resolution, and press the **ENTER** key.
 - Resolution** : 300dpi/ 450dpi/ 600 dpi/ 900 dpi
 - Perform correction for printing resolutions (Y direction).
- 5** Press the **ENTER** key.
 - Printing of the Drop position correct printed pattern will start.
 - Multiple test patterns are printed. (The printed patterns are called Pattern 1, Pattern 2 in the order of printing.)
- 6** Press **▲▼** to enter a correction value of Pattern 1, and press the **ENTER** key.
 - Corrected feeding rate: -40 to 40
 - Check the test patterns. The position where an outward feeding line and a return feeding line become one straight line is the correction value.

- When the correction value is not between -40 and 40, adjust the height of the printing heads and then perform the operations in Step 2 and later.

- 7** In the same way as in Step 6, enter a correction value of Pattern 2, and press the **ENTER** key.

- 8** Press the **END/POWER** key several times to end the setting.



- You can select "DROP.POScorrect" by using the **[FUNCTION]** key in the Local without pressing the **[FUNC2] (ADJUST)** key. (☞ P.3-6)

Printing Data

Starting a Printing Operation

Important!

- When using a roll media, rewind the media by hand before printing so that it is not loose. When the roll media has not been rewound tightly, it may cause the image quality to deteriorate.
- When the same data is printed, the color may differ if print conditions are changed, including the resolution, pass, scanning speed, and printing direction. Check the effects before printing.

1 Setting a Media (☞ P.2-4)

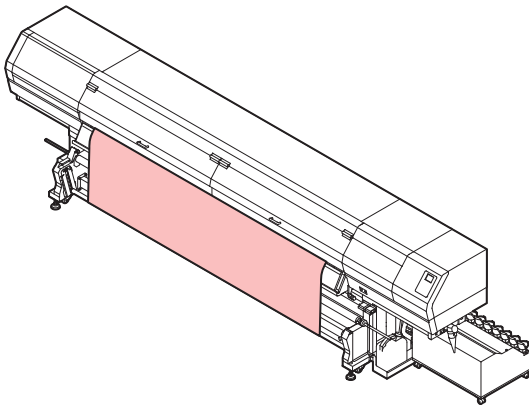

2 Checking the Heater Temperature

3 Press the **FUNC3** (REMOTE) key in LOCAL.

- If the heater temperature has not reached the setting value, the warning message "TEMPERATURE CONTROL" is displayed. Even if it has not reached, you can move to Remote when pressing the [ENTER] key.
- The screen changes to Remote, and data can be received from the PC.

4 Transmit data to be printed from the PC.

- For the method of data transmission, see the instruction manual for the output software.

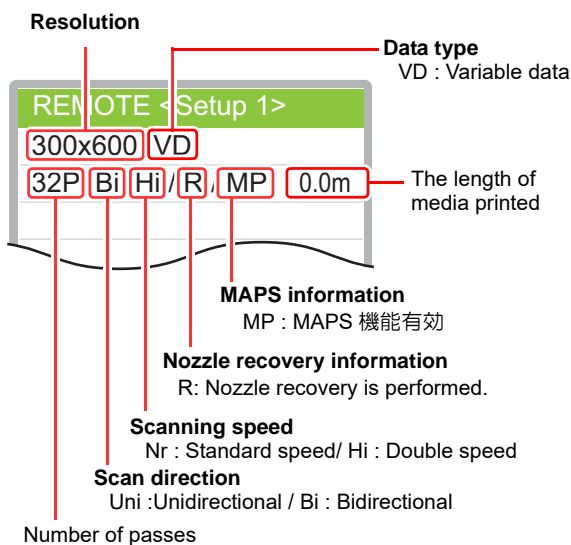

5 Start printing.

- The printing speed may change, depending on the width of the set media or the position of the print origin even when the same data is printed. This is because of a difference in resolution.

Stopping a Printing Operation

Perform the following operation when stopping a printing operation halfway.

1 Press the **FUNC3** (LOCAL) during printing.

- The printing operation stops.
- Interrupt data sending at the PC side during the data is sent from the PC.
- Printing restarts from the interrupted data by repressing the [REMOTE] key.

Deleting Received Data (Data Clear)

When you want to stop printing, delete the already received data.

1 Press the **SEL** key, and press the **FUNC3** (DATA CLEAR) in LOCAL.

2 Press the **ENTER** key.

- The received data is erased then it returns to the Local.

Chapter 3

Extended Functions



This chapter

describes the operation procedures for using the machine more conveniently and each setting procedure.

About Setup MENU.....	3-2	Setting the Display of Media Remain.....	3-15
Setup MENU table	3-3	Setting Time.....	3-15
Register the optimal print conditions to match the use	3-4	Setting Unit (Temperature/ Length)	3-15
Setting of Media Correction.....	3-5	Setting a Key Buzzer	3-15
If the Positions of Dots Shift.....	3-6	Setting the Display of Media Detection.....	3-16
Setting the Heater	3-6	Setting the CONFIRM. FEED	3-16
Setting of Logical Seek	3-7	Set the network.....	3-16
Setting of Overprint	3-7	Setting event mail function.....	3-17
Setting of Left and Right Margins	3-8	Setting the Setting Lock function	3-21
Setting of UV mode	3-8	Initializing the Settings.....	3-21
Setting of Refresh	3-9	About Nozzle Check MENU	3-22
Setting of Vacuum Fan.....	3-9	Nozzle Check MENU table	3-22
Setting of Print Speed	3-10	Printing Check Flow.....	3-23
Setting of MAPS4.....	3-10	Printing Operations at “Nozzle Missing” Judgment and Error Occurrence	3-23
Setting Auto Cleaning	3-10	Setting the Printing Check	3-24
Setting Interval wiping	3-11	Setting the Auto Nozzle Recovery.....	3-24
Setting of LT mode.....	3-11	Setting the Judgement Condition.....	3-24
About Machine Setup MENU	3-12	About Information MENU	3-25
Machine Setup MENU table	3-13	Information MENU table	3-25
Setting a AUTO Power-off.....	3-14	Displaying the Information	3-26
Setting Feeding unit	3-14	Displaying the Information of this machine .	3-26
Setting Take-up unit.....	3-14	Setting a Language	3-27

About Setup MENU

On Setup MENU, you can set the print conditions to match the media you usually use.

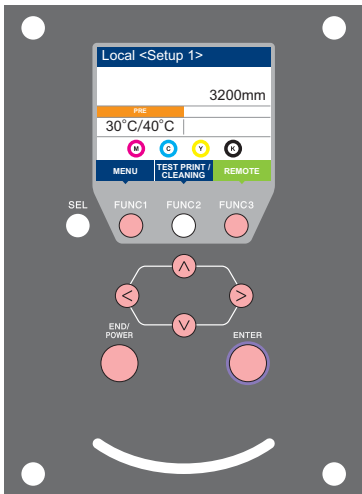

- FUNC1** : Press this to select SETTING MENU, or to switch to the previous screen.
- FUNC2** : Press this to use the adjust function.
- FUNC3** : Press this to switch to the next screen.
- ▲ ▼** : Use these to select a setting item.
- ENTER** : Press this to confirm a setting, etc..

◆ SETUP MENUs at-a-glance

Local <Setup 1>

MENU

Setup

Setup 1 1/4

Setup 1 2/4

Setup 1 3/4

Setup 1 4/4

FUNC1

FUNC2

FUNC3

▲

▼

ENTER

Select "SETUP 1 to 4" or "Temporary", and then press the ENTER key.

◆ Screen transition when **FUNC1** (ADJUST) key is pressed

When adjustment functions (Feed Comp./ X-Distance Comp./ Prop Pos. Correct) are performed, the ADJUST MENU can be displayed easily without selecting [MENU]-[Setup] from Local. Press the [SEL] key to display "ADJUST" for [FUNC1], and then press the [FUNC1] key.

Local <Setup 1>

Adjust

Adjust

FUNC2

▼

Setup MENU table



- For each setting item below, you can set it so that the machine may operate according to the value specified when you printed from your RIP software in the connected host PC.
- **Set Item** : DRYING Time/ Vacuum Fan
- When you operate the machine according to the contents specified with the RIP software, set each item to "Host" when registering this machine type. When you set it other than "Host", the machine operates according to the machine setting.
- For the specifying method with the RIP software, refer to the operation manual of the RIP software.

Function name		Set value *1	When no instruction from RIP exists *2	Outline
Feed Comp. (P.3-5)		-9999 to <u>0</u> to 9999	_____	Used to print a pattern for correcting a media-feeding rate and correct it.
Drop Pos Correct (P.3-6)		-40.0 to <u>0</u> to 40.0	_____	Used to adjust the dot position in go and return printing.
Heater (P.3-6)	PRE	<u>OFF</u> / 20 to 60 °C (<u>OFF</u> / 68 to 140°F)	_____	Sets pre-heater's conditions.
	Ink Heater StandbySwitchoverTime	None, 0 to <u>2</u> to 60min	_____	Sets the movement time until the head heater and ink heater standby status.
Logical Seek (P.3-7)		Data / Media / <u>Quality</u>	_____	Sets the scan movable area during printing.
Overprint (P.3-7)		<u>Host</u> / 1 to 9	1	Sets the number of layers in which ink is to be applied.
Margin/L (P.3-8)		-10 to <u>0</u> to 85mm	_____	Sets a non-printing area along the right and left edges of the media.
Margin/R (P.3-8)			_____	
UV Mode (P.3-8)	AUTO Adjust	-50 to <u>0</u> to 50%	_____	Adjusts the intensity of the UV lamp.
	MANUAL Level	1 to <u>10</u>	_____	Sets the light control method for the UV lamp.
Refresh (P.3-9)		Host / Lv.0 to <u>Lv.3</u>	Lv.3	Sets the interval of refresh performed during printing.
Vacuum Fan (P.3-9)	Host / OFF/ Weak/ <u>Standard</u> / Strong	ON/OFF	Standard	Sets the absorbability of the media.
	Host Weak Standard Strong		_____	
Print Speed (P.3-10)	Feed speed	10 to <u>100</u> %	_____	Changes the media feeding speed in printing.
	Scan Speed	70 to <u>100</u> %	_____	Change the travel speed of the carriage during printing.
MAPS4 (P.3-10)	<u>AUTO</u>	1 / 2 / 3	_____	Perform setting to reduce stripes between passes.
	MANUAL Smoothing Lv.			
Auto Cleaning (P.3-10)	<u>OFF</u> , File, Length, Time		_____	Sets the automatic cleaning operation for the head performed before printing or during printing.
	File Interval	1 to 1000	_____	
	Type	Normal/ Soft/ Hard	_____	
	Length Interval	0.1 to 20.0 to 100.0m	_____	
Type	Normal/ Soft/ Hard	_____	_____	
Type	Normal/ Soft/ Hard	_____	_____	_____
Interval Wiping (P.3-11)		3 to 255 min, <u>OFF</u>	_____	Sets the wiping operation performed after printing is completed.
LT mode (P.3-11)		ON/ <u>OFF</u>	_____	Set LT mode when you need more flexibility than the default UV mode print.
Setup Reset (P.3-5)		The configuration in the settings 1-4 can be reset individually.		

*1. The underlined has been set as default.

*2. This is the setting value to be used for printing when setting value is not specified at the RIP software (host) side, or, you give priority to the setting value at the machine side.

Register the optimal print conditions to match the use

In this machine, you will be able to register print conditions, SETUP 1 to 4 individually to match the media in advance.

For example, after print on different types of media, return to the media always use. In such case you can set the optimum printing conditions by simply selecting the registered SETUP 1 to 4.



- Print conditions that can be pre-registered with the machine are the four types, "SETUP 1" to "SETUP 4".
- If you print with the print condition which do not often use, you will be able to set the print conditions by selecting "Temporary". If turn on the power again, settings in "Temporary" will return to the original state when it was purchased. Also if turn on the power again in "Temporary" state, it will be the state in selecting "SETUP 1".

Register the print conditions to SETUP 1 to 4

- 1 Press the **FUNC1** (MENU) → **ENTER** key in LOCAL.
- 2 Press **▲** **▼** to select SETUP 1 to 4, and press the **ENTER** key.
 - The item selected indicates ● and others show ○.
 - Setup menu will be displayed.
- 3 Press **▲** **▼** to select and set each item in the setup menu list.
 - Please see the reference page in the setup menu list for detailed configuration procedure.

How to use [Temporary]

[Temporary] is not only to set the print condition to be used only once, but also can be used for partial change of the registered SETUP "1 to 4", or for reflecting the print conditions set by the [Temporary] to SETUP 1 to 4.

● Register the print conditions in [Temporary]

Registration of the print conditions to [Temporary] can be done as the same method as to SETUP 1 to 4.

- 1 Press the **FUNC1** (MENU) → **ENTER** key in LOCAL.
- 2 Press **▲** **▼** to select "Temporary", and press the **ENTER** key.
 - Setup menu will be displayed.
- 3 Press **▲** **▼** to select and set each item in the setup menu list.
 - Please see the reference page in the setup menu list for detailed configuration procedure.

● Copy the contents of SETUP 1 to 4 to [Temporary]

You can use it with changing the part of registration contents of Setup 1 to 4.

Select "copy" from the Setup Reset menu of Temporary, and specify the copy source (Setup 1 to 4).

- 1 Press the **FUNC1** (MENU) → **ENTER** key in LOCAL.
- 2 Press **▲** **▼** to select "Temporary", and press the **ENTER** key.
 - Setup menu will be displayed.
- 3 Press the **FUNC1** (<<).
- 4 Press **▲** **▼** to select "Setup Reset", and press the **ENTER** key.
 - Selection screen of the copy source will be displayed.
- 5 Press **▲** **▼** to select "Copy", and press the **ENTER** key.
 - Selection screen of the copy source will be displayed.
- 6 Press **▲** **▼** to SELECT the copy source (SETUP 1 to 4) and press the **ENTER** key.
 - Confirmation screen of the copy will be displayed.
- 7 Press the **ENTER** key.
 - Settings selected in step 5 is copied to Temporary.
- 8 Press **▲** **▼** to select the setting item to be changed, and press the **ENTER** key.
 - Please see the reference page in the setup menu list for detailed configuration procedure.

● Reflect The Content Set In [Temporary] To Setup 1 To 4

- 1 Press the **FUNC1** (MENU) → **ENTER** key in LOCAL.
- 2 Press **▲** **▼** to select "Temporary", and press the **ENTER** key.
 - Setup menu will be displayed.
- 3 Press **▲** **▼** to select and set each item in the setup menu list.
 - Please see the reference page in the setup menu list for detailed configuration procedure.
- 4 Display the last page of Temporary and select "SAVE SETTING", and press the **ENTER** key.
 - Selection screen of the save location will be displayed.

5 Press **▲▼** to select the location selected (SETUP 1 to 4), and press the **ENTER** key.

- Save confirmation screen will be displayed.

6 Press the **ENTER** key.

- Settings of Temporary will be saved to the location selected in step 5.

7 Press the **END/POWER** key several times to end the setting.

Reset the registered contents

Reset the contents registered to SETUP 1 to 4.

1 Press the **FUNC1** (MENU) **➔** **ENTER** key in LOCAL.

2 Press **▲▼** to select SETUP 1 to 4 to be reset and press the **ENTER** key.

- Setup menu will be displayed.

3 Press the **FUNC1** (<<).

4 Press **▲▼** to select "Setup Reset", and press the **ENTER** key.

- Confirmation screen of reset settings will be displayed.

5 Press the **END/POWER** key several times to end the setting.

Setting of Media Correction

Correct the media feed amount to match the type of media you are using.

If the correction value is not appropriate, stripes may appear on the printed image, thus resulting in a poor printing.

- Important!**
- Be sure to perform feed correction each time before printing. The media feed amount may vary, depending on the remaining amount of the roll media.
 - If use by setting the media to Narrow roll holder, rewind the roll media by hand and set without slack. There may not be accurate to correct the feed amount.
 - On completion of [MEDIA COMP.] during use of a roll media, the media returns to the printing origin. When a media is set on the narrow roll holder, slack occurs in the roll media on the backside of this machine. Before printing, take up the slack in the roll media by hand; a loose roll media can result in an inferior image quality.
 - When printing with a take-up device, set the media first and then perform media correction.
 - When printing without using the take-up device, feed the media until the media reaches the floor before performing the correction. Otherwise, the feed amount may not be adjusted normally.

A pattern for media correction is printed and a media-feeding rate is corrected.



- Two bands are printed in the correction pattern.
- Make adjustment so that an even color density is obtained in the boundary between the two bands.

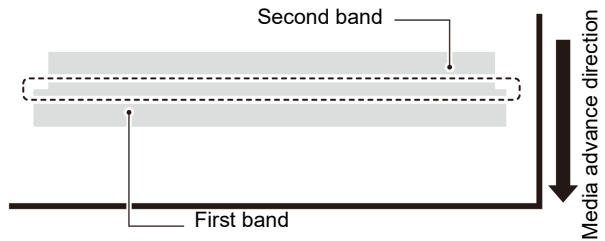

1 Set a media. (☞ P.2-4)

2 Press the **FUNC1** (MENU) **➔** **ENTER** key in Local.

3 Press **▲▼** to select SETUP 1 to 4, and press the **ENTER** key.

- Setup menu appears.

4 Press **▲▼** to select "Feed Comp.", and press the **ENTER** key.

5 Press **▲▼** to enter resolution.

- Here enter the resolution in the scanning direction (Y direction) of the media.



- Enter a resolution matching the data printed usually. This machine changes the media feeding method, depending on the resolution. If you enter a resolution inconsistent with actual printing, it may result in an inappropriate feed amount.

6 Press the **ENTER** key twice to print the correction pattern.

7 Check the correction pattern and enter a correction value.

- A screen for entering the correction value appears.
- **Enter a correction value in "+":**
The boundary between the two bands is widened.
- **Enter a correction value in "-":**
The boundary between the two bands is narrowed.
- When you change the correction value by "25", the width of the boundary changes by about 0.1 mm.

8 Press the **ENTER** key.

- Print a correction pattern again and check it.
- When media correction is needed, perform the operation in Step 6 to make correction.

9 Press the **END/POWER** key several times to end the setting.

Correcting Media-feeding during Printing

A media-feeding rate can be corrected even in the remote mode or when image data is printed.

- 1** Press the **(FUNC1) (ADJUST) → (ENTER)** key in the Remote.
- 2** Press **(▲) (▼)** to enter a corrected feeding rate.
 - Corrected feeding rate: -9999 to 9999
 - The value entered here is reflected in the corrected feeding rate soon.
- 3** Press the **(ENTER)** key twice.
 - key. The changed value is registered.
 - When you press the [ENTER] key instead of the [END/POWER] key, the value entered here will be valid temporarily. (When you perform media detection again or turn the power OFF, the correction value is cleared.)

If the Positions of Dots Shift...

When the condition for printing (Distance of the platen and the head /media thickness/media type/etc.) has been changed, perform the following operation to correct the ink drop position for bidirectional (Bi) printing and obtain the proper printing result.

Example of a Printed Pattern

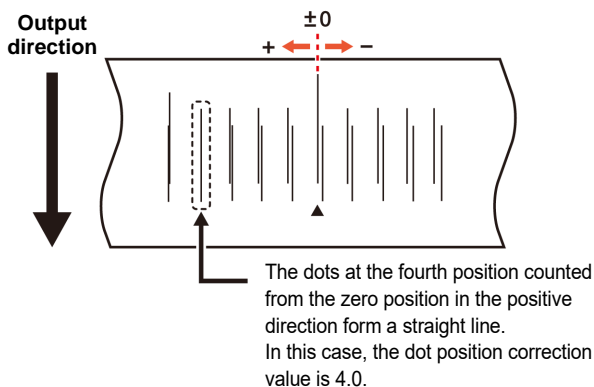

- 1** Set a media. (☞ P.2-4)
 - In order to print a pattern, a media that is 500 mm wide at least is necessary.
- 2** Press the **(FUNC1) (MENU) → (ENTER)** key in Local.
- 3** Press **(▲) (▼)** to select SETUP 1 to 4, and press the **(ENTER)** key.
 - Setup menu appears.
- 4** Press **(▲) (▼)** to select “DROP.POScorrect”, and press the **(ENTER)** key.

- 5** Press **(▲) (▼)** to select resolution, and press the **(ENTER)** key.
 - Resolution : Y300dpi/ Y450dpi/ Y600dpi/ Y900dpi/ Y1200dpi
 - Perform correction for printing resolutions (Y direction).
- 6** Press the **(ENTER)** key.
 - Printing of the Drop position correct printed pattern will start.
 - Multiple test patterns are printed. (The printed patterns are called Pattern 1, Pattern 2 in the order of printing.)
- 7** Press **(▲) (▼)** to enter a correction value of Pattern 1, and press the **(ENTER)** key.
 - Corrected feeding rate: -40 to 40
 - Check the test patterns. The position where an outward feeding line and a return feeding line become one straight line is the correction value.
 - When the correction value is not between -40 and 40, adjust the height of the printing heads and then perform the operations in Step 2 and later.
- 8** In the same way as in Step 6, enter a correction value of Pattern 2, and press the **(ENTER)** key.
- 9** Press the **(END/POWER)** key several times to end the setting.

Setting the Heater

This machine is equipped with a pre-heater on its backside, and contains a print heater to keep the ink at an appropriate temperature.

Type of Heater	Function
Pre-heater	Used for pre-heating of the media prior to printing to prevent rapid temperature changing.
Ink-heater	Set the transition time until the standby status of the head heater and ink heater.

- 1** Press the **(FUNC1) (MENU) → (ENTER)** key in Local.
- 2** Press **(▲) (▼)** to select SETUP 1 to 4, and press the **(ENTER)** key.
 - Setup menu appears.
- 3** Press **(▲) (▼)** to select “Heater”, and press the **(ENTER)** key.
- 4** Press **(▲) (▼)** to select “PRE”, and press the **(ENTER)** key.
- 5** Press **(▲) (▼)** to set the pre-heater temperature, and press the **(ENTER)** key.
 - Heater temperature : OFF/ 20°C to 60°C
- 6** Press **(▲) (▼)** to select “Ink Heater”, and press the **(ENTER)** key.

7 Press **▲▼** to set the Stanby Switch over Time, and press the **ENTER** key.

- Setting value : 0 to 60 min/ NONE

8 Press the **END/POWER** key several times to end the setting.

Setting of Logical Seek

The head's operation varies depending on the Logical Seek settings, as shown in the figure below.

Movement of heads when Logical Seek is "Media".

UNI-DIRECTIONAL

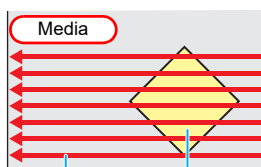

Print area

Red arrow : Movement of head

BI-DIRECTIONAL

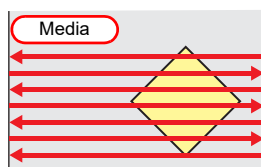

Movement of heads when Logical Seek is "Data".

UNI-DIRECTIONAL

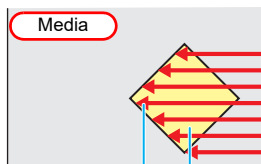

Print area

Red arrow : Movement of head

BI-DIRECTIONAL

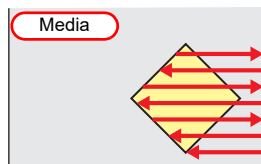

Movement of heads when Logical Seek is "Quality".

UNI-DIRECTIONAL

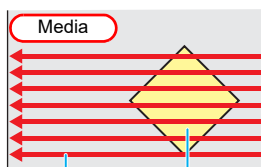

Print area

Red arrow : Movement of head

BI-DIRECTIONAL

The head moves twice the distance of longer side of the set media from the center of the platen as a reference.

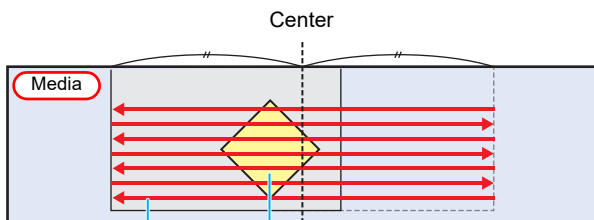

Print area

Red arrow : Movement of head

Important!

If the Logical Seek is set to "Data" or "Media", the following phenomena may occur. In such a case, set the Logical Seek to "Quality".

- The accuracy of the media feed amount is lowered.
- Media skews.
- Lateral stripes occur due to feed variations.

1 Press the **FUNC1** (MENU) **➡** **ENTER** key in Local.

2 Press **▲▼** to select SETUP 1 to 4, and press the **ENTER** key.

- Setup menu appears.

3 Press **▲▼** to select "Logical Seek", and press the **ENTER** key.

4 Press **▲▼** to select a set value, and press the **ENTER** key.

- Set value : Data/ Media/ Quality

5 Press the **END/POWER** key several times to end the setting.

Setting of Overprint

Sets the number of layers in which ink is to be applied.

1 Press the **FUNC1** (MENU) **➡** **ENTER** key in Local.

2 Press **▲▼** to select SETUP 1 to 4, and press the **ENTER** key.

- Setup menu appears.

3 Press the **FUNC3** (>>).

4 Press **▲▼** to select "Overprint", and press the **ENTER** key.

5 Press **▲▼** to set number of Overprint, and press the **ENTER** key.

- Setting value : Host/ 0 to 9 times

6 Press the **END/POWER** key several times to end the setting.

Setting of Left and Right Margins

Set a non-printing area along the left and right edges of the media.

The offset value against the standard margin 15mm is set hereupon.



- The margin setting is enabled only if the media detection method is set to "AUTO".
- The margin setting is reflected when the media width is detected.

- 1 Press the **FUNC1 (MENU)** → **ENTER** key in Local.
- 2 Press **▲** **▼** to select SETUP 1 to 4, and press the **ENTER** key.
 - Setup menu appears.
- 3 Press the **FUNC3 (>>)**.
- 4 Press **▲** **▼** to select "Margin/L" or "Margin/R", and press the **ENTER** key.
- 5 Press **▲** **▼** to select a set value, and press the **ENTER** key.
 - Set value : -10 to 85 mm
- 6 Press the **END/POWER** key several times to end the setting.



- Pay attention to the settings of the right and left margins when printing with the media press. If any of the margins is set to a negative value, printing may start from a position on the media press.

Setting of UV mode

Set the amount of light for the UV lamp of the LED UV device.



- The color tone may differ if any of the UV mode settings is changed. Check in advance that the color tone will not be affected.

Setting of Mode

There are two types of setting of mode available as shown below.

Setting item	Descriptions
AUTO	Prints with an amount of light recommended for each of the printing modes.
MANUAL	Select this if the curing level is not good when AUTO is selected.

Normally, select "AUTO".

If the level of ink curing is strong/weak, adjust the UV lamp intensity by using "Light Adjust" in the "AUTO" settings.

If adjustment cannot be made even by using "Light Adjust" in the "AUTO" settings, select "MANUAL".

- To adjust the amount of light in the "AUTO" settings

- 1 Press the **FUNC1 (MENU)** → **ENTER** key in Local.
- 2 Press **▲** **▼** to select SETUP 1 to 4, and press the **ENTER** key.
 - Setup menu appears.
- 3 Press the **FUNC3 (>>)**.
- 4 Press **▲** **▼** to select "UV Mode", and press the **ENTER** key.
- 5 Press the **ENTER** key.
- 6 Press **▲** **▼** to select "AUTO", and press the **ENTER** key.
- 7 Press **▲** **▼** to select "Light Adjust", and press the **ENTER** key.
- 8 Press **▲** **▼** to set the adjustment value for the intensity of the LED UV device, and press the **ENTER** key.
 - Set value : -50% to +50%
 - If you set this value to 0%, the machine applies an intensity recommended for each of the printing modes.
 - Setting a negative value reduces the intensity; setting a positive value increases the intensity.
- 9 Press the **END/POWER** key several times to end the setting.

- If you fail to adjust the amount of light in the "AUTO" settings

- 1 Press the **FUNC1 (MENU)** → **ENTER** key in Local.
- 2 Press **▲** **▼** to select SETUP 1 to 4, and press the **ENTER** key.
 - Setup menu appears.
- 3 Press the **FUNC3 (>>)**.
- 4 Press **▲** **▼** to select "UV Mode", and press the **ENTER** key.
- 5 Press the **ENTER** key.
- 6 Press **▲** **▼** to select "MANUAL", and press the **ENTER** key.
- 7 Press **▲** **▼** to select "PATTERN", and press the **ENTER** key.

8 Pressing to select a UV lamp irradiation pattern.

- **Set value** : Pattern A to H
- A recommended scan direction for printing is fixed for each pattern.
Change the pattern according to the scan direction for printing.
- The curing level differs depending on the pattern.
If you want to increase the level of ink curing, try patterns one after another, starting with the pattern with the highest level of curing.
If you want to decrease the level of ink curing, try patterns one after another, starting with the pattern with the lowest level of curing.

Pattern	Scan direction		Curing level
	Bi-directional	Uni-directional	
A	+	+	++
B	+	x	+
C	+	x	-
D	N/A	+	+
E	N/A	+	+
F	+	x	N/A
G	x	+	N/A
H	x	+	-

<Curing level>
Higher ++ > + > - > N/A lower

9 Press the key.

10 Press to select "Light Level", and press the key.

11 Press to set the level for the intensity of the LED UV device, and press the key.

- **Set value** : Lv 1 to 10
- Lowering the level decreases the intensity.
Raising the level increases the intensity.
Use Lv 5 to check the state of ink curing first, and increase the value to strengthen the curing level and decrease the level to weaken the curing level.

12 Press the key several times to end the setting.

● UV Mode Setup Procedure

Example: To weaken the curing level in bi-directional printing

- (1) In the "AUTO" settings, set "Light Adjust" in the negative direction.
- (2) Even when "-50%" is set for "Light Adjust", if the ink curing level is strong, select "MANUAL".
 - Set F for "Pattern".
 - Set Lv5 for "Light Level".
- (3) Check the state of ink curing.
 - If the curing level is strong: Reduce the light level.
 - If the curing level is weak: Increase the light level.
- (4) If an appropriate amount of light cannot be obtained even by changing the value for "Light Level", change the pattern.
- (5) Repeat steps from (3) to (4) to set the pattern and light level that helps obtain an appropriate amount of light.

Setting of Refresh

Sets the interval of refresh performed during printing.

1 Press the key in Local.

2 Press to select SETUP 1 to 4, and press the key.

- Setup menu appears.

3 Press the key.

4 Press to select "Refresh", and press the key.

5 Press to select a set value, and press the key.

- **Set value** : Host/Lv.0 to Lv.3.

6 Press the key several times to end the setting.

Setting of Vacuum Fan

Sets the absorbability of the media.

By setting the absorption power to match the media, you can prevent print errors due to media rise-up.

1 Press the key in Local.

2 Press to select SETUP 1 to 4, and press the key.

- Setup menu appears.

3 Press the key.

4 Press to select "Vacuum Fan", and press the key.

5 Press to select a set value, and press the key.

- **Set value** : Host/Weak /Standard/ Strong/ OFF

6 If you choose any other option than "OFF" in step 4, press , choose whether to constantly operate the vacuum fan, and press the key

- **ON** : Vacuum fan is constantly on.
- **OFF** : Vacuum fan is only on when printing or performing jog operation.

7 Press the key several times to end the setting.



- When switch the setting 1 to 4 /Temporary or copy the setting, there is a case that the setting screen of vacuum fan is displayed.

Setting of Print Speed

Changes the media feeding speed and scanning speed in printing.

- 1 Press the **FUNC1** (MENU) → **ENTER** key in Local.
- 2 Press **▲▼** to select SETUP 1 to 4, and press the **ENTER** key.
 - Setup menu appears.
- 3 Press the **FUNC1** (<<).
- 4 Press **▲▼** to select "Print Speed", and press the **ENTER** key.
- 5 Press **▲▼** to select a setting item, and press the **ENTER** key.
 - Set value : Feed Speed / Scan Speed
- 6 Press **▲▼** to select a set value, and press the **ENTER** key.
 - Set value of "Feed Speed":10 to 100%
 - Set value of "Scan Speed":70 to 100%
- 7 Press the **END/POWER** key several times to end the setting.

- Important!**
- Changing the print speed setting may change the color. After changing the print speed, check whether there is any change in color beforehand.
 - After changing scan setting, perform dot position correction (☞ P.3-6)
 - After changing the feed setting value, perform feed correction (☞ P.3-5)

Setting of MAPS4

If performing media correction does not resolve feeding stripes, use the MAPS (Mimaki Advanced PassSystem) function to disperse the pass boundary to make the feeding stripes less visible.



- Changing the MAPS4 settings may change the color tone. Check the effects before use.
- MAPS may not be effective depending on image to be printed. Use it after checking effect in advance.

● Conditions disabling MAPS function

When the conditions which do not show "MP" in the display during printing is set, MAPS function is disabled. (☞ P.2-26)

In addition, by the image to be printed, there is a case that the effects of the MAPS can not be obtained.

Setting MAPS4 Function

- 1 Press the **FUNC1** (MENU) → **ENTER** key in Local.

- 2 Press **▲▼** to select SETUP 1 to 4, and press the **ENTER** key.
 - Setup menu appears.

- 3 Press the **FUNC1** (<<).

- 4 Press **▲▼** to select "MAPS4", and press the **ENTER** key.

- 5 Press **▲▼** to select a set value, and press the **ENTER** key.

- Set value : AUTO/ MANUAL
- If you have selected "MANUAL", proceed to step 5. Otherwise, proceed to step 9.

- 6 Press **▲▼** to select the "Pattern", and press the **ENTER** key.

- 7 Press **▲▼** to select the "Type", and press the **ENTER** key.

- Set value : Pattern1, Pattern 2 and Pattern 3

Important!

- MAPS4 effect differs depending on image to be printed. Change the printing pattern and use it after checking effect in advance.

- 8 Press **▲▼** to select the "Smoothing Lv.", and press the **ENTER** key.

- 9 Press **▲▼** to change the smoothing level, and press the **ENTER** key.

- Set Value : 0 to 100% (set in units of 5%)
- The MAPS4 effect become strong as the set value increase, and become weak as the set value decrease.
- When use a white ink, set both the smoothing level for the color ink and white ink.

- 10 Press the **END/POWER** key several times to end the setting.

Setting Auto Cleaning

You can set the machine so that it counts the number of printed files or the length or time has been completed, and performs cleaning automatically if required.

You can select the auto cleaning setting from three types below:

- **File** : Set the cleaning intervals by the number of printed files.
- **Length** : Set the cleaning intervals by the printed length.
- **Time** : Set the cleaning intervals by the printed time.

The machine can perform a stable printing operation with its heads always kept clean.

- 1 Press the **FUNC1** (MENU) → **ENTER** key in Local.

- 2 Press **▲▼** to select SETUP 1 to 4, and press the **ENTER** key.

- Setup menu appears.

3 Press the **FUNC1** (<<) key.

4 Press **▲▼** to select "AUTO CLEANING", and press the **ENTER** key.

5 Press **▲▼** to select the type of auto cleaning, and press the **ENTER** key.

- There are "File", "Length" and "Time" for auto cleaning.

File : When the set files has been completed, the machine performs head cleaning automatically.

Length : When the set length has passed, the machine performs head cleaning automatically.

Time : When the set time has passed, the machine performs head cleaning automatically.

- If you do not set auto cleaning, first select "OFF" and then proceed to the Step 7.

Important! • The color tone may change, depending on the timing when auto cleaning is performed. Check in advance that the color tone is not affected.

6 Press **▲▼** to select the "Interval", and press the **ENTER** key.

- Depending on the auto cleaning type selected in the Step 3, the setting value differs.

For File : 1 to 1000 File

For Length : 0.1 to 100.0m (in 0.1m increment)

For Time : 10 to 100min (in 10min increment)

7 Press **▲▼** to select the "Type" and then press the **ENTER** key.

- Set Value : Normal/ Soft/Hard

8 Press the **END/POWER** key several times to end the setting.

Important! • Depending on the state of the heads, etc., the image quality deterioration may not be improved even with this function performed. In this case, contact your local distributor, our sales office or our call center.

Setting Interval wiping

When a set time has elapsed, the machine automatically wipes the nozzle surfaces of the head to remove any ink droplets attached to the surfaces.

In case that deflection, nozzle missing, or symptom which ink droplets fall down occurred, set the interval between each operation shorter.

1 Press the **FUNC1** (MENU) **➔** **ENTER** key in Local.

2 Press **▲▼** to select SETUP 1 to 4, and press the **ENTER** key.

- Setup menu appears.

3 Press the **FUNC1** (<<) key.

4 Press **▲▼** to select "Interval Wiping", and press the **ENTER** key.

5 Press **▲▼** to set intervals.

- Set Value : 3 to 255 Minutes, OFF
- When [OFF] is set, periodical wiping is not executed.

6 Press the **ENTER** key.

7 Press the **END/POWER** key several times to end the setting.

Important! • The color tone may change, depending on the timing when periodic wiping is performed. Check in advance that the color tone is not affected.

Setting of LT mode

1 Press the **FUNC1** (MENU) **➔** **ENTER** key in LOCAL.

2 Press **▲▼** to select SETUP 1 to 4, and press the **ENTER** key.

- Setup menu appears.

3 Press **FUNC3** (>>).

4 Press **▲▼** to select "LT mode", and press the **ENTER** key.

5 Press **▲▼** to select set value, and press the **ENTER** key.

- Set Value: ON / OFF

6 Press the **END/POWER** key several times to end.

Important! • Since UV light intensity adjustment is performed, check the print performance (stickiness, odor etc.) before using the LT mode.
• Effective condition

Ink set	Printing mode	Media
LUS120 4 colors	300×900 dpi 8 pass Standard speed Bidirectional	Tarpaulin
	600×600 dpi 8 pass Double speed Bidirectional	FF
LUS120 6 colors	300×900 dpi 16 pass Standard speed Bidirectional	Tarpaulin
	600×600 dpi 16 pass Double speed Bidirectional	FF

* "LT" is displayed in the printing condition of remote display during printing in LT mode.

About Machine Setup MENU

Common settings are functions for using this machine easily.
The following items can be set in Machine settings.



- (FUNC1)** : Press this to select Machine Setup MENU, or to switch to the previous screen.
- (FUNC3)** : Press this to switch to the next screen.
- (↑)(↓)** : Use these to select a setting item.
- (ENTER)** : Press this to confirm a setting, etc..

◆ Machine Setup MENUs at-a-glance

The sequence of screenshots illustrates the following navigation path:

- Local <Setup 1>**: Press **(FUNC1)** twice to enter the **MENU**.
- MENU**: Press **(ENTER)** to select **Machine Setup**.
- Machine Setup**: Press **(↓)** to select **Auto Power-off**.
- Machine Setup**: Press **(↑)** to select **Feeding Unit**.
- Machine Setup**: Press **(↑)** to select **Take-up Unit**.
- Machine Setup**: Press **(↑)** to select **Media Remain**.
- Machine Setup**: Press **(↑)** to select **Time Set**.
- Machine Setup**: Press **(↑)** to select **Unit / Temp**.
- Machine Setup**: Press **(↑)** to select **Unit / Length**.
- Machine Setup**: Press **(↑)** to select **Key Buzzer**.
- Machine Setup**: Press **(↑)** to select **Media Detect**.
- Machine Setup**: Press **(↑)** to select **View Feed**.
- Machine Setup**: Press **(↑)** to select **Network&Mail**.
- Machine Setup**: Press **(↑)** to select **Reset**.

Machine Setup MENU table

Function name		Set value		Default	Meaning		
AUTO Power-off (P.3-14)		NONE/ 10 ~ 600min		30min	When no operation has been performed for the set time, the power supply is automatically turned "OFF".		
Feeding Unit (P.3-14)		ON/ OFF		ON	You can set the operation method when the ON/ OFF button on the take-up unit is pressed.		
Take-up Unit (P.3-14)		ON/ OFF		ON	You can set the operation method when the ON/ OFF button for the take-up device is pressed.		
Media Remain (P.3-15)		ON/ OFF		OFF	You can control the remaining amount of media.		
TIME (P.3-15)		+4h ~ -20h			Time difference is corrected.		
UNIT/ TEMP. (P.3-15)		°C (Centigrade)/°F (Fahrenheit)		°C	A unit for displaying temperature is set.		
UNIT/ Length (P.3-15)		mm / inch		mm	A unit for displaying length and area is set.		
Key Buzzer (P.3-15)		OFF / ON		ON	A buzzer sound when keys are pressed is set.		
Media Detect (P.3-16)		AUTO/MANUAL		AUTO	Set the media detection method.		
CONFIRM. FEED (P.3-16)		ON / OFF		ON	Set whether media feeding is performed for checking the result of the test printing etc. or not.		
Network & Mail	Network (P.3-16)	Set the network.					
		Check IP Address	The IP address currently used by this machine is displayed.				
		Check MAC Address	The IP address currently used by this machine is displayed.				
		DHCP	ON / OFF		When it is ON, the IP address given by the DHCP server is used.		
		AutoIP	ON / OFF		When it is ON, the IP address is determined by the AutoIP protocol. However, DHCP is ON, DHCP has priority.		
		IP Address *1	Set the IP address used by this machine.				
		Def.Gateway *1	Set the default gateway used by this machine.				
		DNS Address *1	Set the DNS server address used by this machine.				
		SubNet Mask *1	Set the digit number of the subnet mask used by this machine.				
	Event Mail (P.3-17)	Mail Delivery	ON / OFF	OFF	Set whether you send/ do not send the e-mail when the set event occurs.		
		Select Event	Print Start	ON / OFF	OFF	Set whether you send/ do not send the e-mail at the start of printing.	
			Print End	ON / OFF	OFF	Set whether you send/ do not send the e-mail at the end of printing.	
			Error Event	ON / OFF	OFF	Set whether you send/ do not send the e-mail when an error occurs.	
			Warning Event	ON / OFF	OFF	Set whether you send/ do not send the e-mail when a warning occurs.	
			Other Event	ON / OFF	OFF	Set whether you send/ do not send the e-mail when an event other than the above occurs.	
		Mail Address	Set the e-mail address to which you send the event mail.	Alphanumeric characters and symbols (within 96 characters)			
		Message Subject	Set the characters to write in the subject of the event mail.	Alphanumeric characters and symbols (within 8 characters)			
		Server Setup	SMTP Address		Set the SMTP server.		
			SMTP PORT No.		Set the SMTP port number.		
			SENDER ADDRESS		Set the e-mail address to be used as the sender mail address.		
Auth.	POP before SMTP		Set the SMTP server authentication method (SMTP authentication).				
	SMTP Auth						
	OFF						
USER NAME *2		Set the user name used for the authentication.					
PASS WORD *2		Set the password used for the authentication.					
Server Setup	POP3 ADDRESS *3		Set the POP server.				
	APOP *3		Set ON/ OFF of APOP.				

Function name		Set value	Default	Meaning
Network & Mail	Event Mail (P.3-17)	Transmit Test	Send the test e-mail.	
	Setting Lock (P.3-21)	Lock (Password is not set) Unlock (Password is set)	0000 to 9999	0000 You can freely specify a four digit password so that no one other than an administrator can perform network and mail settings.
Reset (P.3-21)				All setting values are returned to the status default.

*1. Settable when both of DHCP and AutoIP are [OFF]

*2. Settable only when Auth. is not OFF

*3. Settable only when Auth. is POP before SMTP

Setting a AUTO Power-off

When no operation has been performed for the set time, the power supply is automatically turned "OFF".

- 1 Press the **FUNC1** (MENU) in Local.
- 2 Press **▲▼** to select "Machine Setup", and press the **ENTER** key.
- 3 Press **▲▼** to select "AUTO POWER OFF", and press the **ENTER** key.
- 4 Press **▲▼** to select a set value, and press the **ENTER** key.
 - Set Value : none, 10 to 600min
- 5 Press the **END/POWER** key several times to end the setting.

Important!

• If the machine received data from the PC in the auto-power-off status, the power supply is turned ON, however, printing operation is not started automatically.

Setting Feeding unit

For setting whether the Feeding unit is used or not used.

- 1 Press the **FUNC1** (MENU) in Local.
- 2 Press **▲▼** to select "Machine Setup", and press the **ENTER** key.
- 3 Press **▲▼** to select "Feeding Unit", and press the **ENTER** key.
- 4 Press **▲▼** to select a set value, and press the **ENTER** key.
 - Set Value : ON/ OFF
- 5 Press the **END/POWER** key several times to end the setting.

Setting Take-up unit

For setting whether the take-up unit is used or not used.

- 1 Press the **FUNC1** (MENU) in Local.
- 2 Press **▲▼** to select "Machine Setup", and press the **ENTER** key.
- 3 Press **▲▼** to select "Take-up Unit", and press the **ENTER** key.
- 4 Press **▲▼** to select a set value, and press the **ENTER** key.
 - Set Value : ON/ OFF
- 5 Press the **END/POWER** key several times to end the setting.

Setting the Display of Media Remain

Whether the screen displays the remaining amount of a media is set.

When the media remaining amount display is turned to "ON"	the remaining amount of a media is displayed in Remote. (However, when a leaf media is used, the length of the media to be printed is displayed.)
When the media remaining amount display is turned to "OFF"	the remaining amount of a media is not displayed in the Remote.



- The displayed amount of a media is a rough indication. It may be different from the actual remaining amount.



- The amount of a media that has been fed by the printing and jog keys is reflected in the remaining amount of a media.
- The length of a media (initial value of the remaining amount) is entered when a roll media is detected. (P.2-10)
- The setting configured here does not become effective unless media detection is performed after the setting has been complete.

- Press the **FUNC1** (MENU) in Local.
- Press **▲▼** to select "Machine Setup", and press the **ENTER** key.
- Press **▲▼** to select "Media Remain", and press the **ENTER** key.
- Press **▲▼** to select ON/OFF.
- Press the **ENTER** key.
- Press the **END/POWER** key several times to end the setting.

Setting Time

You can set time of your country (time difference).

- Press the **FUNC1** (MENU) in Local.
- Press **▲▼** to select "Machine Setup", and press the **ENTER** key.
- Press **▲▼** to select "TIME", and press the **ENTER** key.
- Press **FUNC2** (✓).
 - You will be able to change the time.

- Press **▲▼◀▶** to enter time, and press the **ENTER** key.
 - Year/Month/Day/Time selecting: by the [**◀**][**▶**] keys.
 - Year/Month/Day/Time inputting: by the [**▲**][**▼**] keys.

- Press the **END/POWER** key several times to end the setting.



- As for the time difference, -20 hours to +4 hours can be set.

Setting Unit (Temperature/ Length)

Units used by this machine are set.

- Press the **FUNC1** (MENU) in Local.
- Press **▲▼** to select "Machine Setup", and press the **ENTER** key.
- Press the **FUNC3** (>>).
- Press **▲▼** to select "Unit/Temp" or "Unit/Length", and press the **ENTER** key.
- Press **▲▼** to select a set value, and press the **ENTER** key.
 - Set value of tempature : °C / °F
 - Set value of length : mm / inch
- Press the **END/POWER** key several times to end the setting.

Setting a Key Buzzer

You can turn off the buzzer sound when pressing the key.

- Press the **FUNC1** (MENU) in Local.
- Press **▲▼** to select "Machine Setup", and press the **ENTER** key.
- Press the **FUNC3** (>>).
- Press **▲▼** to select "Key Buzzer", and press the **ENTER** key.
- Press **▲▼** to select a set value, and press the **ENTER** key.
 - Set value : ON/ OFF
- Press the **END/POWER** key several times to end the setting.



- The buzzer sound is not disabled for errors, warnings and/or operation completion even if this setting is set to "OFF".

Setting the Display of Media Detection

Set the following two items in media detection settings.

Setting of Media Detection	When loading the media, set whether to detect the media width automatically (AUTO) or decide the print range manually (MANUAL).
-----------------------------------	---



- When using the media that cannot be detected by the sensor, set the media detection setting to "MANUAL".
- When "MANUAL" is selected, the values of "MARGIN (RIGHT/LEFT)" on the SETUP MENU have no effect. (☞ P.3-8)

- 1 Press the **FUNC1** (MENU) in Local.
- 2 Press **▲▼** to select "Machine Setup", and press the **ENTER** key.
- 3 Press the **FUNC3** (>>) .
- 4 Press **▲▼** to select "Media Detect", and press the **ENTER** key.
- 5 Press **▲▼** to select AUTO/MANUAL, and press the **ENTER** key.
- 6 Press the **END/POWER** key several times to end the setting.







Setting the CONFIRM. FEED

Set whether media feeding is performed for checking the result of the test printing etc. or not.

- 1 Press the **FUNC1** (MENU) in Local.
- 2 Press **▲▼** to select "Machine Setup", and press the **ENTER** key.
- 3 Press the **FUNC3** (>>) .
- 4 Press **▲▼** to select "CONFIRM. FEED", and press the **ENTER** key.
- 5 Press **▲▼** to select a set value, and press the **ENTER** key.
 - Set value : ON/ OFF
- 6 Press the **END/POWER** key several times to end the setting.

Set the network

- 1 Press the **FUNC1** (MENU) in Local.
 - 2 Press **▲▼** to select "Machine Setup" and press the **ENTER** key.
 - 3 Press the **FUNC1** (<<).
 - 4 Press **▲▼** to select "Network & Mail" and press the **ENTER** key.
 - 5 Press **▲▼** to select "Network" and press the **ENTER** key.
 - 6 Press **▲▼** to select "Check IP Address" and press the **ENTER** key.
 - The IP address currently used by this machine is displayed.
- After connecting with the network, it takes time until the IP address is determined. If the IP address has not been determined, "0.0.0.0" is displayed.
- 7 Press **▲▼** to select "Check MAC Address" and press the **ENTER** key.
 - The MAC address currently used by this machine is displayed.
 - 8 Press **▲▼** to select "DHCP" and press the **ENTER** key.
 - Press **▲▼** to set ON/ OFF.
 - When it is ON, the IP address given by the DHCP server is used.
 - 9 Press **▲▼** to select "AutoIP" and press the **ENTER** key.
 - Press **▲▼** to set ON/ OFF.
 - When it is ON, the IP address is determined by the AutoIP protocol. However, DHCP is ON, DHCP has priority.
 - 10 Press **▲▼** to select the set values and press the **ENTER** key.
 - Both of DHCP and AutoIP is OFF, you can set IP Address/ Default Gateway/ DNS Address/ Sub Net Mask. For other than above, proceed to the Step 13.

- 11** Press     to select the set values.
- 12** Press  to confirm the value.
- 13** Press the  key several times to end the setting.



- To reflect network setting, once turn off the power supply and then turn it on again.

Setting event mail function

Set the function to send e-mails to the set e-mail address when events such as cutting start/ end and stop due to an error.



















Disclaimer

- The customer is responsible for the communication fee for Internet communication such as e-mail notification.
- The notification by the event mail function may not be delivered due to Internet environment, failure of the machine/ the power supply, etc. Mimaki has absolutely no responsibility for any damages or loss resulting from non-delivery or delays.

Important!

- You can use event mail function by connecting LAN to this machine. Please prepare for LAN cable connection beforehand.
- Not compatible with SSL communication.

Enable the event mail function

- 1** Press the  (MENU) in Local.
- 2** Press   to select "Machine Setup" and press the  key.
- 3** Press the  (<<).
- 4** Press   to select "Network & Mail" and press the  key.
- 5** Press   to select "Event Mail" and press the  key.
- 6** Press   to select "Mail Delivery" and press the  key.
- 7** Press   to select "ON" and press the  key.
- 8** Press the  key several times to end the setting.

Set the event to send an event mail

- 1 Press the **FUNC1** (MENU) in Local.
- 2 Press **▲▼** to select “Machine Setup” and press the **ENTER** key.
- 3 Press the **FUNC1** (<<).
- 4 Press **▲▼** to select “Network & Mail” and press the **ENTER** key.
- 5 Press **▲▼** to select “Event Mail” and press the **ENTER** key.
- 6 Press **▲▼** to select “Select Event” and press the **ENTER** key.
- 7 Press **▲▼** to select the event, and press the **FUNC2** (✓).
 - After selecting the event, press the [FUNC2] key and put a check in the check box. An email will be sent when the event whose box has been checked occurs.
 - To select multiple events, use **▲▼** to put the cursor over the events you want, and put a check in their boxes by pressing [FUNC2].

Event name	Outline
Print Start	Sets sending/not sending of an email when printing starts.
Print End	Sets sending/not sending of an email when printing ends.
Error Event	Sets sending/not sending of an email when printing is stopped due to occurrence of an error.
Warning Event	Sets sending/not sending of an email when a warning occurs during printing.
Other Event	Sets sending/not sending of an email when an event other than the above occurs.

- 8 Press the **ENTER** key.
- 9 Press the **END/POWER** key several times to end the setting.

Set the e-mail address

- 1 Press the **FUNC1** (MENU) in Local.
- 2 Press **▲▼** to select “Machine Setup” and press the **ENTER** key.
- 3 Press the **FUNC1** (<<).
- 4 Press **▲▼** to select “Network & Mail” and press the **ENTER** key.
- 5 Press **▲▼** to select “Event Mail” and press the **ENTER** key.
- 6 Press **▲▼** to select “Mail Address” and press the **ENTER** key.
- 7 Press **▲▼◀▶** to set mail address and press the **ENTER** key.
 - Set the e-mail address to which you send the event mail.
 - Set it with alphanumeric characters and symbols within 96 characters.
- 8 Press the **END/POWER** key several times to end the setting.

Set the subject

- 1 Press the **FUNC1** (MENU) in Local.
- 2 Press **▲▼** to select “Machine Setup” and press the **ENTER** key.
- 3 Press the **FUNC1** (<<).
- 4 Press **▲▼** to select “Network & Mail” and press the **ENTER** key.
- 5 Press **▲▼** to select “Event Mail” , and press the **ENTER** key.
- 6 Press **▲▼** to select “Message Subject” and press the **ENTER** key.
- 7 Press **▲▼◀▶** to set subject, and press the **ENTER** key.
 - Set the characters to write in the subject of the event mail.
 - Set it with alphanumeric characters and symbols within 8 characters.
- 8 Press the **END/POWER** key several times to end the setting.

Set the server

- 1** Press the **(FUNC1)** (MENU) in Local.
- 2** Press **(▲)(▼)** to select “Machine Setup” and press the **(ENTER)** key.
- 3** Press the **(FUNC1)** (<<).
- 4** Press **(▲)(▼)** to select “Network & Mail” and press the **(ENTER)** key.
- 5** Press **(▲)(▼)** to select “Event Mail” , and press the **(ENTER)** key.
- 6** Press **(▲)(▼)** to select “Server Setup” and press the **(ENTER)** key.
- 7** Press **(▲)(▼)** to select “SMTP Address” and press the **(ENTER)** key.
- 8** Press **(▲)(▼)(◀)(▶)** to set SMTP Address and press the **(ENTER)** key.
 - Press the jog key [**▲**][**▼**][**◀**][**▶**] to set SMTP address.
 - Input the SMTP address name.
- 9** Press **(▲)(▼)** to select “SMTP Port No.” , and press the **(ENTER)** key.
- 10** Press **(▲)(▼)** to set SMTP Port No. and press the **(ENTER)** key.
 - Set the SMTP port number.
- 11** Press **(▲)(▼)** to select “Sender Mail Address” and press the **(ENTER)** key.
- 12** Press **(▲)(▼)(◀)(▶)** to set Sender Mail Address and press the **(ENTER)** key.
 - Press [**▲**][**▼**][**◀**][**▶**] and set the e-mail address to be used as the sender mail address.
 - Set it with alphanumeric characters and symbols within 64 characters.



 - Depending on your server, if you do not set the e-mail address not supporting the account, sending/ receiving e-mails may be unavailable.
- 13** Press **(▲)(▼)** to select “Authentication” and press the **(ENTER)** key.
- 14** Press **(▲)(▼)** to set authentication method, and press the **(ENTER)** key.
 - Set the authentication method of the SMTP server.
 - When you select [POP before SMTP], proceed to the Step 15.
 - If you select [SMTP Authentication], after the operation of the steps 15-18, go to step 23.
 - When you select [OFF], proceed to the Step 23.
- 15** Press **(▲)(▼)** to select “User Name” and press the **(ENTER)** key.
- 16** Press **(▲)(▼)(◀)(▶)** to set User Name and press the **(ENTER)** key.
 - Press [**▲**][**▼**][**◀**][**▶**] to set the user name to use for the authentication.
 - Set it with alphanumeric characters and symbols within 30 characters.
- 17** Press **(▲)(▼)** to select “Password” and press the **(ENTER)** key.
- 18** Press **(▲)(▼)(◀)(▶)** to set Password and press the **(ENTER)** key.
 - Press [**▲**][**▼**][**◀**][**▶**] to set the password to use for the authentication.
 - Set it with alphanumeric characters and symbols within 15 characters.

 - On the password setting screen, you can only check the value that you are currently inputting.
- 19** Press **(▲)(▼)** to select “POP3 Address” and press the **(ENTER)** key.
- 20** Press **(▲)(▼)(◀)(▶)** to set POP3 Address and press the **(ENTER)** key.
 - Press [**▲**][**▼**][**◀**][**▶**] to set POP server.
 - Input the POP server name.
- 21** Press **(▲)(▼)** to select “APOP” and press the **(ENTER)** key.
- 22** Press **(▲)(▼)** to set ON/ OFF and press the **(ENTER)** key.
- 23** Press the **(END/POWER)** key several times to end the setting.

Send a test e-mail

- 1 Press the **FUNC1** (MENU) in Local.
- 2 Press **▲▼** to select “Machine Setup” and press the **ENTER** key.
- 3 Press the **FUNC1** (<<).
- 4 Press **▲▼** to select “Network & Mail” and press the **ENTER** key.
- 5 Press **▲▼** to select “Event Mail” and press the **ENTER** key.

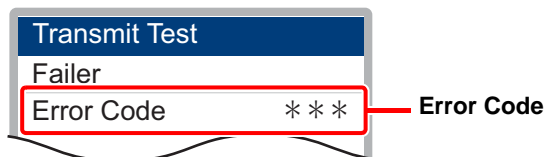
- 6 Press the **FUNC3** (>>) **→** **ENTER** key.
 - “Transmit Test” will be selected.
- 7 Press the **ENTER** key.
 - The sent result is displayed.
 - If sending test e-mail has failed, an error code is displayed.
 - Refer to the next page to solve the problem.



- 8 Press the **END/POWER** key several times to end the setting.

Important!

- The sent result of the test e-mail is the result of e-mail sending process performed by this machine to the e-mail server. It does not indicate that the e-mail was received at the address.
- If the spam e-mail filter etc. has been set in the terminal in which e-mails are received, even if “Sending has been completed” is displayed, the e-mail cannot be received in some cases.
- If sending test e-mail has failed, the error code below is displayed.
- If the error cannot be solved, try again after a while.
- For the server setting etc., contact with the network administrator or the provider.

Error Code	The expected casus	Remedy
10	Network connection error	<ul style="list-style-type: none"> • Check that the machine is connected with the network. • Check that the machine IP address is correct. • Check that the machine is in the environment where DNS is available.
20	No valid e-mail address.	<ul style="list-style-type: none"> • Enter the correct e-mail address.
11003 11004	The POP server cannot be found. Or cannot access DNS server.	<ul style="list-style-type: none"> • Check the POP server address. • Check that the machine is in the environment where DNS is available.
11021	Cannot connect with the POP server.	<ul style="list-style-type: none"> • Check the POP server setting. • Check the firewall setting.
12010	An error returns from the POP server.	<ul style="list-style-type: none"> • Check the POP server setting.
13000	The POP authentication has failed.	<ul style="list-style-type: none"> • Check the user name and the password. • Check the APOP setting. • Confirm the authentication method.
10013 10014	The SMTP server cannot be found. Or cannot access DNS server.	<ul style="list-style-type: none"> • Check the SMTP server address. • Check that the machine is in the environment where DNS is available.
10021	Cannot connect with the SMTP server.	<ul style="list-style-type: none"> • Check the SMTP server setting. • Check the SMTP port number. • Check the firewall setting.
10*** 11*** 20*** 21***	An error returns from the SMTP server.	<ul style="list-style-type: none"> • Check the SMTP server setting. • Cannot communicate with a server that requires mandatory SSL communication. • Check protocol filter settings.
12***	It is invalid sender address.	<ul style="list-style-type: none"> • Check that the e-mail address supporting the account entered in the user name/ the password is set in SENDER ADDRESS.
13***	The e-mail address cannot be found.	<ul style="list-style-type: none"> • Check the e-mail address. • Even if there is a mistake in the e-mail address, this error cannot be detected in some cases.
22000 22008	SMTP authentication error	<ul style="list-style-type: none"> • Confirm the authentication method.
23*** 24*** 25***	The SMTP authentication has failed.	<ul style="list-style-type: none"> • Check the user name and the password.

“***” is the error code returned from the e-mail server.

Setting the Setting Lock function

You can freely specify a four digit password so that no one other than an administrator can perform network and mail settings.

Specifying the password for the network and event mail functions

- 1 Press the **FUNC1** (MENU) in Local.
- 2 Press **▲▼** to select "Machine Setup" and press the **ENTER** key.
- 3 Press the **FUNC1** (<<).
- 4 Press **▲▼** to select "Network & Mail" and press the **ENTER** key.
- 5 Press **▲▼** to select "Setting Lock" and press the **ENTER** key.
- 6 Specify a freely chosen password (four digits) and press the **ENTER** key.
 - A notification that setting has started is briefly displayed.
- 7 Press the **END/POWER** key several times to end the setting.

Releasing the password for the network and event mail functions

- 1 Press the **FUNC1** (MENU) in Local.
- 2 Press **▲▼** to select "Machine Setup" and press the **ENTER** key.
- 3 Press the **FUNC1** (<<).
- 4 Press **▲▼** to select "Network & Mail" and press the **ENTER** key.
- 5 Press **▲▼** to select "Setting Lock" and press the **ENTER** key.
- 6 Enter a four-digit password and press the **ENTER** key.
 - **If releasing is a success**The screen is displayed a message "Release Success".
 - **If releasing is a failure**The screen is displayed a message "Release failure".

- 7 Press the **END/POWER** key several times to end the setting.

Important!

- If you forget the password, you can press the "[FUNC2] (✓)" key displayed in the screen of Step 7 to display the password forced release screen. Be careful as although you can press the [ENTER] key to forcibly release the password, items set for the network and event mail also return to their initial values, making it necessary to re-specify them.

Initializing the Settings

You can return the setting of "SETUP", "Maintenance" and "Machine Setup" to the status before shipment.

- 1 Press the **FUNC1** (MENU) in Local.
- 2 Press **▲▼** to select "Machine Setup", and press the **ENTER** key.
- 3 Press the **FUNC1** (<<).
- 4 Press **▲▼** to select "Reset", and press the **ENTER** key.
- 5 Press the **ENTER** key.
 - The already configured settings are initialized.
- 6 Press the **END/POWER** key several times to end the setting.

About Nozzle Check MENU

Set operations concerning the nozzle missing detection function.

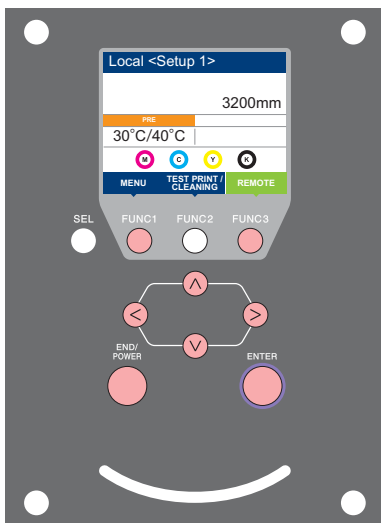

- FUNC1** : Press this to select Nozzle Check MENU, or to switch to the previous screen.
- FUNC3** : Press this to switch to the next screen.
- ▲ ▼** : Use these to select a setting item.
- ENTER** : Press this to confirm a setting, etc..

◆ NCU MENUs at-a-glance

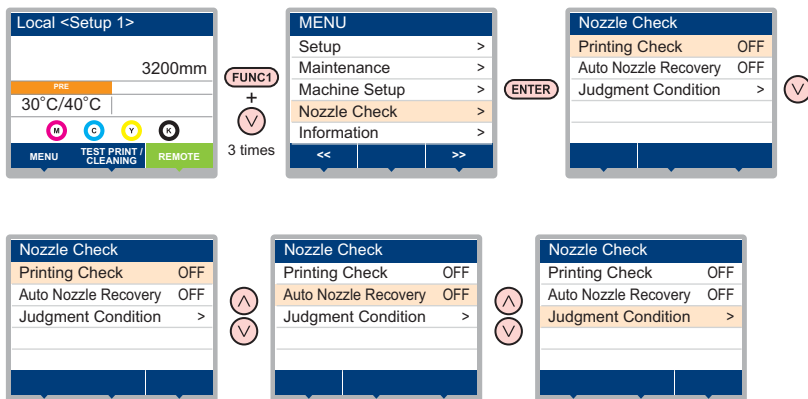

Nozzle Check MENU table

Function name		Set value	Default	Meaning	
Printing Check (🔧 P.3-24)		ON/OFF	OFF	Set this when you want to conduct nozzle check at the beginning of online printing.	
(ON)	Check Interval	Length	0.1 to 50.0m	30.0 m	Conducts nozzle check at each set length.
		FILE	1 to 100	30 file	Conducts nozzle check at each set number of files. *1
	Action	Cleaning	Soft/ Normal / Hard	Soft	Sets the type of cleaning performed during recovery work.
		Retry Count	0 to 3	1	Repeats the retry operation for the set number of times.
Auto Nozzle Recovery (🔧 P.3-24)		ON/OFF	OFF	Set this when you want to conduct automatic nozzle recovery. (Maximum 16 per 1 nozzle line)*2	
Judgement Condition (🔧 P.3-24)		1 to 64	1	Sets how many missing nozzles are detected for "Nozzle Missing" judgment to be made according to each color.	

*1. When the set length is reached during printing, nozzle check is conducted at the start of the next printing.

*2. Depending on the print conditions, nozzle recovery is not applied in some cases. (🔧 P.4-15)

Printing Check Flow

Nozzle check is conducted according to the following flow at the start of printing.

Important!

- Turn the “Printing Check” setting ON to be enabled.
- Only perform Retry Count and Printing Check settings when the settings are enabled.

1 nozzle check → Judgment

Detects missing nozzles.

2 Recovery operation → nozzle check → Judgment

If more missing nozzles than “Judgement Condition ” are detected after the nozzle check, cleaning is performed and nozzle check is conducted again.

3 Retry → Judgment

If more missing nozzles than “Judgement Condition ” are detected after the recovery operation, the recovery operation is conducted again.

4 Printing Check → Judgment

Nozzle recovery is automatically conducted following nozzle check and recovery operation.

- Turn the “Printing Check” setting ON to be enabled.

5 Nozzle Missing judgment

If more missing nozzles than A are eventually detected, continued printing will be deemed impossible and printing will stop.

3

Printing Operations at “Nozzle Missing” Judgment and Error Occurrence

- **When judged to be “Nozzle Missing”** → Printing is stopped.
- **When error occurs during nozzle check** → Printing is stopped and “Printing Check” is automatically turned OFF. After recovering from the error, set “Printing Check” once again.

Setting the Printing Check

Select ON when you want to conduct nozzle check at the start of online printing.

- 1 Press the **FUNC1** (MENU) in Local.
- 2 Press **▲▼** to select "Nozzle Check", and press the **ENTER** key.
- 3 Press **▲▼** to select "Printing Check", and press the **ENTER** key.
- 4 Press **▲▼** to select ON, and press the **ENTER** key twice.
 - The "Check Interval" setting screen appears.
 - "Select OFF to not set nozzle check. Proceed to Step 11.
- 5 Press **▲▼** to select "Setup", and press the **ENTER** key.
- 6 Press **▲▼** to select setting value, and press the **ENTER** key.
 - select the nozzle check interval from "Length" or "FILE".
 - Length** : nozzle check is conducted when the printed length reaches the set length.
 - FILE** : nozzle check is conducted when the number of printed files reaches the set number.
- 7 Press **▲▼** to select "Interval", and press the **ENTER** key.
- 8 Press **▲▼** to select setting value, and press the **ENTER** key.
 - The set value will differ according to the setting selected in Step 5.
 - Length** : 0.1 to 100 m
 - FILE** : 0 to 300 files
- 9 Press the **END/POWER** key.
- 10 Press **▲▼** to select "Continuation Print", and press the **ENTER** key.
- 11 Press **▲▼** to select setting value, and press the **ENTER** key.

Setting value : Stop/ Continue
- 12 Press **▲▼** to select cleaning type, and press the **ENTER** key.
- 13 Press **▲▼** to select setting value, and press the **ENTER** key.

Setting value: Soft/ Normal/ Hard
- 14 Press **▲▼** to select retry count, and press the **ENTER** key.

Setting value: 0 to 3

- 15 Press the **END/POWER** key several times to end the setting.

Setting the Auto Nozzle Recovery

set this if you want to conduct automatic nozzle recovery when nozzle missing is detected.

- 1 Press the **FUNC1** (MENU) in Local.
- 2 Press **▲▼** to select "Nozzle Check", and press the **ENTER** key.
- 3 Press **▲▼** to select "Auto Nozzle Recovery", and press the **ENTER** key.
- 4 Press **▲▼** to select ON/OFF, and press the **ENTER** key.
- 5 Press the **END/POWER** key several times to end the setting.

Setting the Judgement Condition

Set the conditions for judging nozzle missing.

- 1 Press the **FUNC1** (MENU) in Local.
- 2 Press **▲▼** to select "Nozzle Check", and press the **ENTER** key.
- 3 Press **▲▼** to select "Judgement Condition", and press the **ENTER** key.
- 4 Press **▲▼** to select color, and press the **ENTER** key.
- 5 Press **▲▼** to set the number of nozzles for judgment, and press the **ENTER** key.
- 6 Press the **END/POWER** key several times to end the setting.

About Information MENU

The information of this machine can be confirmed.

The following items can be confirmed as machine information.

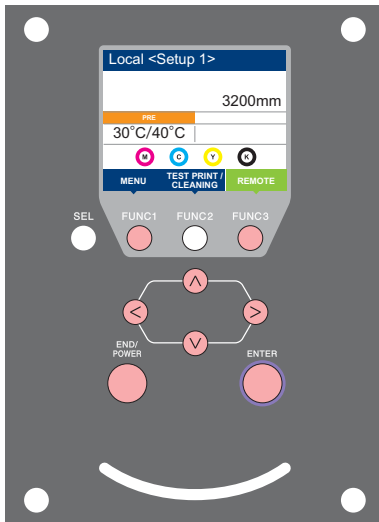

FUNC1 : Press this to select Information MENU, or to switch to the previous screen.

FUNC3 : Press this to switch to the next screen.

▲ **▼** : Use these to select a setting item.

ENTER : Press this to confirm a setting, etc..

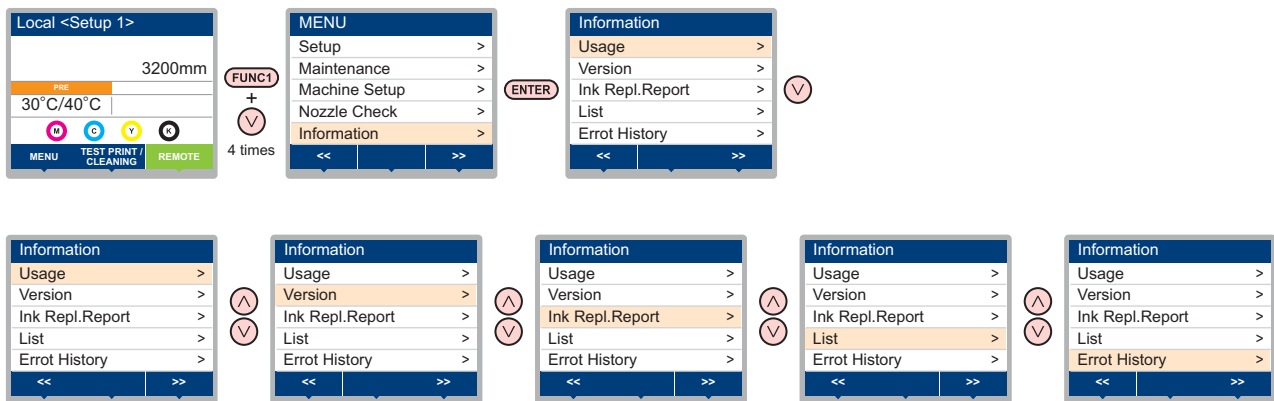

Information MENU table

Item		Description
USAGE	WIPING	This displays how many wipings have been done.
	PRINT Length	This displays the total length of the printing done to date.
	PRINT AREA	This displays the total area of the printing done to date.
	USE TIME	This displays the total time for which the machine has been used to date.
	UV LAMP	This displays the total time for which each of the UV lamps has been illuminated.
VERSION		This displays the version information of this machine.
Ink REPL. Report		This prints ink history of this machine.
List		This allows you to print the settings of this machine.
ERROR HISTORY		This displays the history of errors and warnings to date. When you press [▲][▼], the date of occurrence (year/month/day/hour/minute) and the error/warning information are displayed alternately in the order of occurrence.

Displaying the Information

- 1 Press the **[FUNC1]** (MENU) in Local.
- 2 Press **[▲][▼]** to select “Information”, and press the **[ENTER]** key.
 - Information MENU appears.
- 3 Press **[▲][▼]** to select a information.
 - Refer to the “Information MENU”, and select the information to be displayed.
- 4 Press the **[ENTER]** key.
 - If you selected [List] in step 2, the machine’s settings will be printed.
- 5 Press the **[END/POWER]** key several times to end the setting.

Resetting wiper use count

- 1 “USAGE” of Information Menu is displayed.
 - (1) Press the [FUNC1] (MENU) in Local
 - (2) Press [▲][▼] to select “Information”, and press the [ENTER] key twice.
- 2 Press **[▲][▼]** to select “WIPING”, and press the **[FUNC2]** (✓).
 - A confirmation screen appears asking if you want to clear the use count of the wiper.
- 3 Press the **[ENTER]** key to clear the counter.
 - The use count of the wiper is cleared.

Checking Uv Lamp Use Time

- 1 “USAGE” of Information Menu is displayed.
 - (1) Press the [FUNC1] (MENU) in Local
 - (2) Press [▲][▼] to select “Information”, and press the [ENTER] key twice.
- 2 Press **[▲][▼]** to select “UV LAMP”, and press the **[ENTER]** key.
 - The use time is displayed for each of the UV lamps.

Displaying the Information of this machine

- 1 Press the **[ENTER]** key in Local.
- 2 The information is displayed sequentially with the **[ENTER]** (or **[◀][▶]**)key.
 - The information shown on the below appear.

Ink information



- if the sub tank error has occurred, press the [F2] key to display the number of the sub tank that error occurs.

LUS120	
1. (M) 90%	No Error
2. (C) 80%	No Error
3. (Y) 70%	No Error
4. (K) 82%	No Error

Error/ Warning (Only at the time of occurrence)

Warning	
Media Undetected	

Machine information (Media width/ Serial No. /Version)

Media width	3200mm
Serial No.	'00000000
UJV55-320	V1.00

Expiration date of ink

Ink Expiration	
M	17/01
C	17/01
Y	17/01
K	17/01

Nozzle recovery

Nozzle Recovery	
M	0
C	0
Y	0
K	0

Nozzle check

Nozzle Check	
M	0
C	0
Y	0
K	0

- 3 Press the **[END/POWER]** key to return to Local.

Setting a Language

You can change the displayed language.

- 1** Press the **FUNC1 (MENU)** → **FUNC1 (<<)** → **ENTER** key in Local.
 - Language MENU appears.
- 2** Press **▲** **▼** to select language, and press the **ENTER** key.
 - Set Value : 日本語 / English / Español / Português / 中文
- 3** Press the **END/POWER** key several times to end the setting.

Chapter 4

Maintenance



This chapter

describes the items required to use this machine more comfortably, which are the methods for the daily care, the maintenance of the ink unit etc.





Maintenance	4-2	Washing the Head Nozzle	4-13
Precautions for Maintenance	4-2	Nozzle Recovery Function	4-14
About Cleaning Solution	4-2	Automatic Maintenance Function	4-16
Ink Maintenance	4-2	Setting the Refreshing level	4-16
Cleaning the Exterior Surfaces	4-2	Setting the Cleaning level	4-16
Cleaning the Platen	4-2	Setting the Cleaning level for White ink	4-17
Cleaning of pre-heater cover and		About white ink circulation function	4-17
Image quality confirmation LED Light	4-3	Discarding waste ink	4-18
Cleaning the Media Sensor	4-3	For waste ink remaining management	4-19
Cleaning the Media Press	4-4	Adjust the waste ink	4-19
About Maintenance MENU	4-5	Replacing consumables	4-20
Maintenance MENUs at-a-glance	4-6	Replacing the wiper	4-20
Maintaining the Capping Station	4-7	Replacing the Mist Fan Filter (H fan filter)	4-20
Cleaning the Wiper and Cap	4-7	Replace the ink tank and ink filter	4-22
Washing the Ink Discharge Passage	4-9	Tank Calibration	4-23
When the Machine Is Not Used for a Long Time		Replacing the cap absorber	4-25
(Custody Wash)	4-10	Refilling antifreeze mixed water	4-26
Cleaning the Ink Head and the Area		Refill antifreeze mixed water	4-27
around It	4-12		
When nozzle missing Cannot Be Solved	4-13		

Maintenance

Maintain the machine regularly or as necessary so that its accuracy will be maintained and it can continue to be used for a long time.

Precautions for Maintenance

Pay attention to the following items when maintaining this machine.

	<ul style="list-style-type: none"> When using cleaning solution for maintenance, be sure to wear the supplied glove and protective glasses.
	<ul style="list-style-type: none"> Never disassemble the machine. Disassembling it can result in electric shock hazards or damage to the machine. Before maintenance, be sure to turn off the power button and main power switch, and unplug the power cable; otherwise, an unexpected accident may occur.
	<ul style="list-style-type: none"> Prevent moisture from entering the machine. Moisture inside the machine can cause electric shock hazards or damage to the machine.
	<ul style="list-style-type: none"> To ensure stable ink jetting, it is necessary for the machine to eject a small amount of ink (flushing) regularly when a printing (outputting) operation has not been performed for a long time. When the machine is not to be used for a long time, turn off only the power button on the front side, leave the main power switch at the side turned ON (in the position of), and leave the power cable connected.
	<ul style="list-style-type: none"> Do not use benzine, thinner, or any chemical agent containing an abrasive. Such materials can deteriorate or deform the surface of the cover. Do not apply a lubricant, etc. to any parts inside the machine. Doing so can cause printing failure. Be careful that the cleaning solution, ink, etc. not to stick to the cover because this may cause the surface of the cover to deteriorate or deform.

About Cleaning Solution

Use the cleaning liquid dedicated for the ink being used.

Type of Ink	Applicable maintenance washings
UV ink	Washing liquid for maintenance (SPC-0568)

Cleaning the Exterior Surfaces

When the exterior surfaces of the machine are stained, dampen a soft cloth with water or a neutral detergent diluted with water, squeeze it, and wipe the surfaces with the cloth.

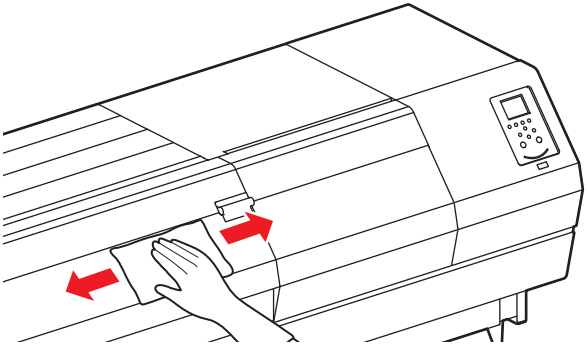

- Do not allow liquids to get inside the product. Ingress of liquids into the product may lead to failure, electric shock, or fire.

Cleaning the Platen

Continuing to use the media while it is dirty may cause media to be fed incorrectly, or rubbing dirt or solid ink onto the head nozzle surface, resulting in discharge failure (nozzle clogging, deflection, etc.).

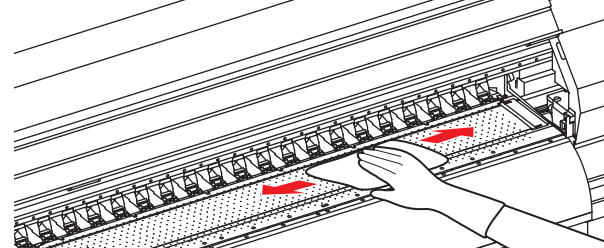

- Turn off the main power and unplug the power cable before maintenance.
- Do not allow liquids to get inside the product. Ingress of liquids into the product may lead to failure, electric shock, or fire.



- When the platen is stained with ink, wipe it off with a paper towel containing a small amount of cleaning solution for maintenance.



- Before cleaning the platen, make sure that the pre-heater has cooled adequately.
- When cleaning the platen, do not apply strong force to the platen or wipe it with a hard cloth. Doing so may damage or deform the platen, causing poor printed image. If the deformed platen is used, the media may meander and the print head may be damaged.

Cleaning of pre-heater cover and Image quality confirmation LED Light

The pre-heater cover and the image quality confirmation LED light are easy to be dirty because of the powder of the media etc.

If it shows dirt, wipe it with a soft cloth soaked in water or waterish mild detergent and wrung.

- Important!** • Before cleaning the cover, be sure to check that the pre-heater temperature is low enough.

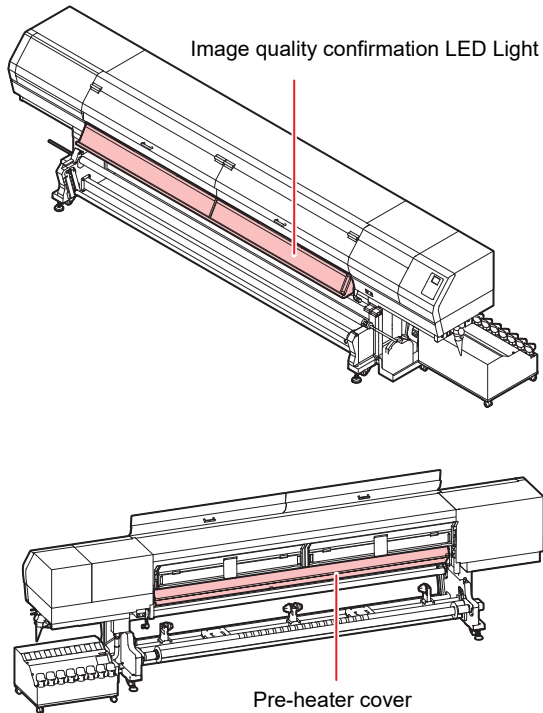

Cleaning the Media Sensor

The media sensors are located on the platen in the backside (3 places) and the bottom surface of the head (1 place). When the sensor is covered with dust, etc., it may cause false detection of media.

Using a cotton swab, remove the dust, etc. accumulated on the surface of the sensor.

When cleaning the sensor on the lower surface of the head is cleaned, move the carriage to the left end by the operations of step 1 of P.4-12 "Cleaning the Ink Head and the Area around It", and clean it.



- Do not press against the sensor with the cotton swab. Doing so could damage the sensor.

The backside of the machine

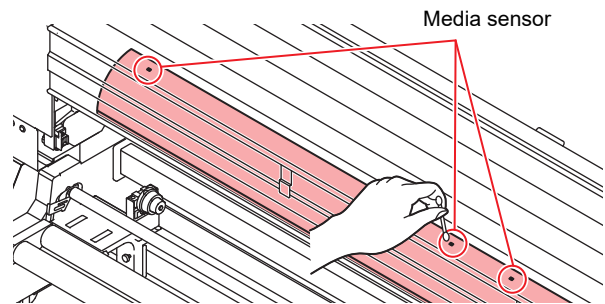

The lower surface of the head

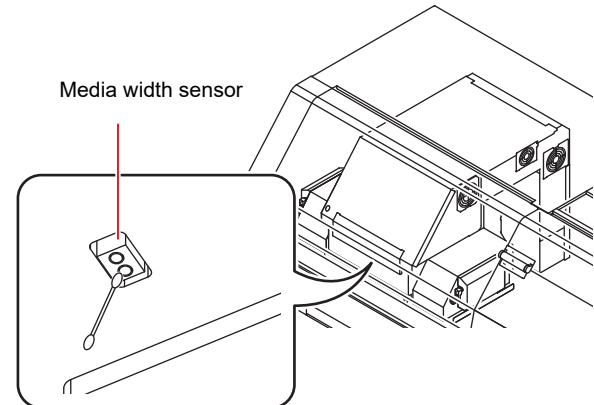

Cleaning the Media Press

When the media press is covered with lint, dust, etc., a media cannot be fed normally during printing or dust sticks to the nozzles, which may result in abnormal printing.

Clean the media press regularly with a dry cloth or paper towel.

If there is ink on the media press, wipe it away with a clean stick dipped in washing liquid for maintenance.



- Turn off the main power and unplug the power cable before maintenance.
- Do not allow liquids to get inside the product. Ingress of liquids into the product may lead to failure, electric shock, or fire.



- When using washing liquid for maintenance, be sure to wipe it away completely so that none remains on the media press.

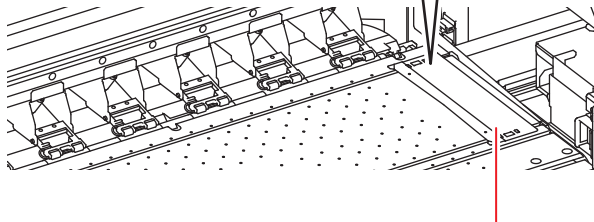
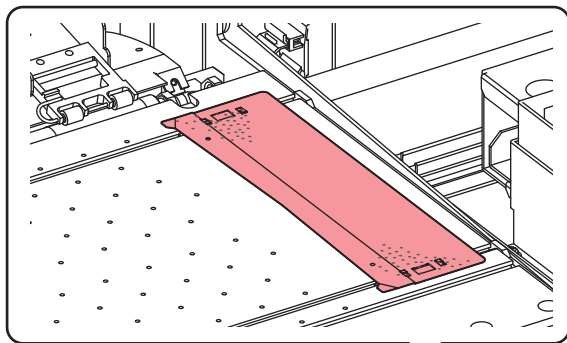

Media press

About Maintenance MENU

This provides various settings for doing maintenance on the machine.
The following items can be set in Maintenance settings.

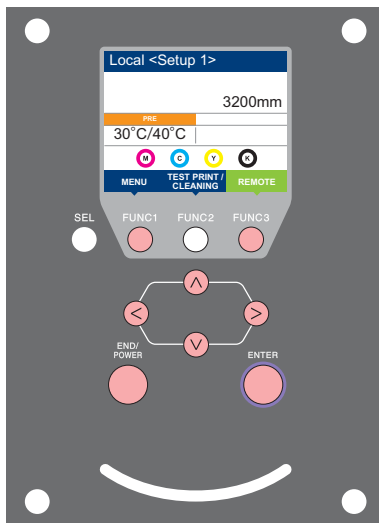

- FUNC1** : Press this to select Maintenance MENU, or to switch to the previous screen.
- FUNC2** : Press this to use the maintenance function.
- FUNC3** : Press this to switch to the next screen.
- FUNC3** : Use these to select a setting item.
- ▲ ▼** : Press this to confirm a setting, etc..
- ENTER**

Maintenance MENUs at-a-glance

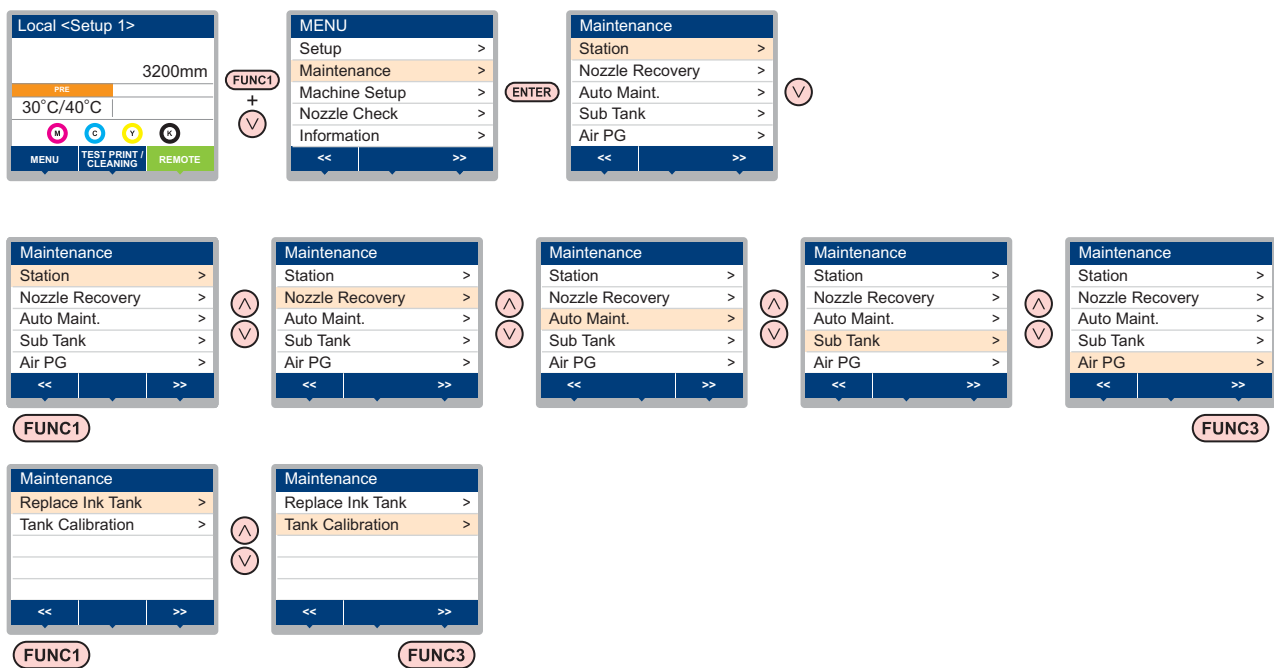

◆ Press the **FUNC2** key to perform “Station maintenance”.

The Station MENU can be displayed easily without selecting [MENU]-[Maintenance] from Local.
Press the [SEL] key to display “TEST PRINT/CLEANING” for [FUNC2], and then press the [FUNC2] key.

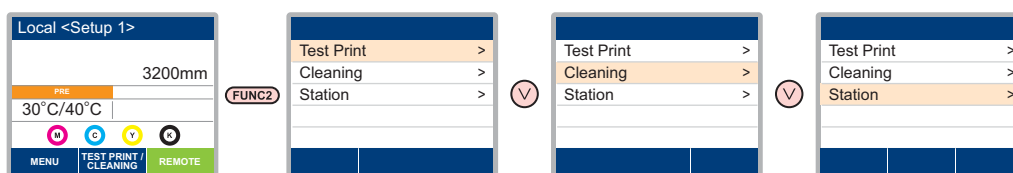

Maintenance MENUs at-a-glance

Item	Set value	Meaning
Station	For carrying out maintenance on the carriage and station periphery.	
	Carriage Out (☞ P.4-7)	_____ Moves the carriage out, for carrying out cleaning of the cap periphery, head, wipers, etc.
	Nozzle Wash (☞ P.4-13)	1 to 60min Soaks the nozzle surfaces in maintenance cleaning fluid, for carrying out recovery from nozzle missing or bent.
	Pump Tube Wash (☞ P.4-9)	_____ Executes washing of the suction pump tubes.
	Custody Wash (☞ P.4-10)	1 to 60min Carried out when the machine is going to be out of use for an extended period. Washes the nozzles and tubes beforehand, to keep the machine in fine condition.
	Replace Wiper (☞ P.4-20)	_____ Used when replacing the wiper. If the wiper is replaced, the number of times the wiper was used that is managed in this machine is reset.
Nozzle Recovery (☞ P.4-14)	For printing using another nozzle, if nozzle wash and so forth fail to effect recovery from nozzle missing, etc.	
	PRINT	_____ Used to print a pattern and to check and/or register clogged nozzles.
	ENTRY	_____ Registers the faulty nozzle identified by "PRINT".
	CLEAR	_____ Resets a registered faulty nozzle.
Auto Maint. (☞ P.4-16)	For having the various maintenance functions executed automatically. Set the execution interval for each maintenance function.	
	Refresh	OFF/Lv.1/Lv.2/ Lv.3 Set the interval of the refresh activation.
	Cleaning	OFF/Lv.1/Lv.2/ Lv.3 Set the activation interval of the head cleaning.
	Cleaning (White)	OFF/Lv.1/Lv.2/ Lv.3 Set the activation interval of the head cleaning for white ink.
Sub Tank (☞ P.5-4)	Used to charge ink and to solve the problems including ink errors and nozzle missing .	
Air PG (☞ P.5-5)	Removes any air inside the print head causing poor discharge.	
Replace Ink Tank (☞ P.4-22)	Used to replace an ink tank and to reset the ink charge information.	
Tank Calibration (☞ P.4-22)	Make the correction of the weight balance of the ink supply unit.	

Maintaining the Capping Station

Maintain the ink cap, wiper, etc. located in the capping station. (Station maintenance)

The ink cap and wiper function as follows.

- **Wiper** : It wipes off ink sticking to the head nozzles.
- **Ink cap** : It prevents the head nozzles from clogging due to dryness.

As the machine is used repeatedly, the wiper and ink cap gradually become dirty with ink, dust, etc. If nozzle missing cannot be corrected even after head cleaning (☞ P.2-23) has been performed, use a Washing liquid for maintenance and clean stick.

Tools required for Maintenance

- | | | |
|---|----------|------------------|
| • Washing liquid for maintenance (SPC-0568) | | |
| • Clean stick (SPC-0527) | • Gloves | • Safety glasses |



- Be sure to wear the supplied safety glasses and gloves when maintaining the capping station. Otherwise, you may get ink in your eyes.
- Do not move the carriage out of the capping station by hand. When it is desirable to move the carriage, press the [FUNC2] (TEST PRINT/CLEANING) key to execute the carriage-out. (☞ P.4-7 Steps 1 to 2)
- Be sure to perform maintenance for the ink cap and the wiper of capping station every day. If you leave it dirty, dirt may adhere to the nozzle surface, or, dust and dry ink may be rubbed against the nozzle. It may cause discharge defect.
- While working, be careful to avoid subjecting the capping station to direct sunlight. Ultraviolet light will cure UV ink. Take measures to block sunlight, such as closing the curtains on windows.

Cleaning the Wiper and Cap

It is recommended that the wiper and cap be cleaned frequently in order to maintain the high image quality of the machine and keep the machine itself in good working order.

Important!

- When work is complete at the end of the day, clean the wipers and surrounding areas.
- Replace the wiper with a new one when it is extremely dirty or bent. (☞ P.4-20)
- When cleaning the wiper, be careful that lint from the clean stick does not get left on the wiper. Remaining lint may cause image quality to deteriorate.

1 Press the **[FUNC2]** (TEST PRINT/CLEANING), and press the **[ENTER]** key in Local.

2 Press **[▲]** **[▼]** to select “Station”, and press the **[ENTER]** key.

- The Station MENU appears.

3 Press **[▲]** **[▼]** to select “CARRIAGE OUT”, and press the **[ENTER]** key.

4 Press **[▲]** **[▼]** to select “Station”, and press the **[ENTER]** key.

- Press the [ENTER] key in the Execution Check screen, and the carriage moves over the platen.

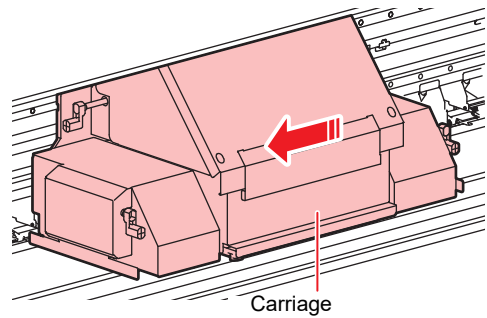

5 Open the right side maintenance cover.

- (1) Rotate the screws under the right side maintenance cover (for two positions) to the left and remove them.
- (2) Hold the bottom of the right side maintenance cover and pull it to the front.
- (3) While pulling the right side maintenance cover downward, remove it.

- If the right side maintenance cover is hard to remove, use the supplied screwdriver.

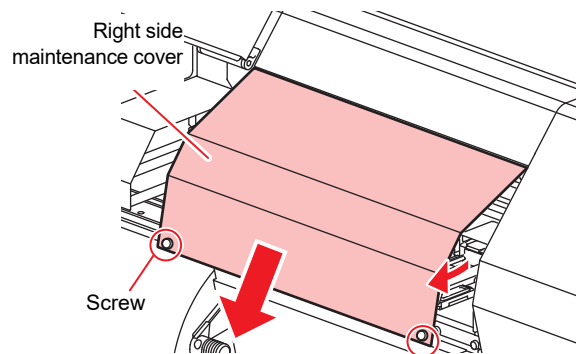

6 Remove the wiper.

- Pull out the wiper by holding the protrusions at its both ends.

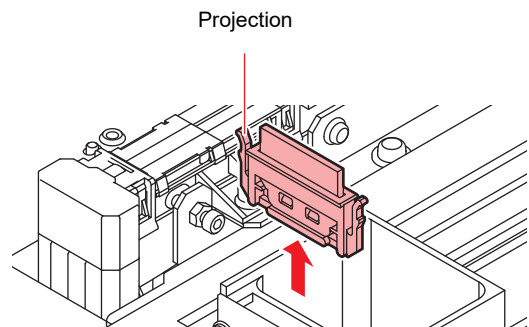

7

Clean the wiper and bracket.

- Wipe off the ink sticking to the wiper and bracket with a clean stick dipped in cleaning solution for maintenance. Wipe off so that cleaning solution for maintenance will not remain.

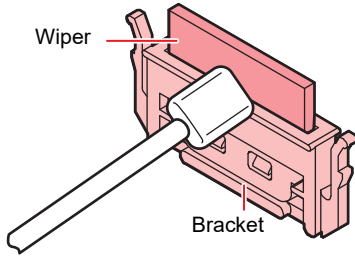

8

Clean the wiper cleaner.

- Wipe off the ink sticking to the wiper cleaner with a clean stick dipped in cleaning solution for maintenance. Wipe off so that cleaning solution for maintenance will not remain.

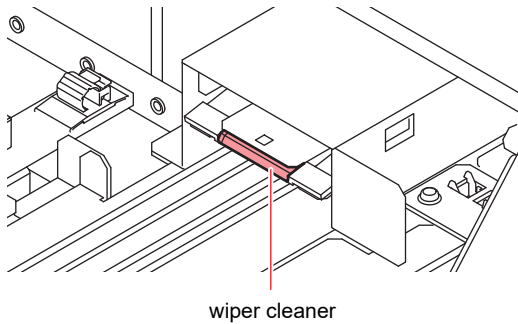

9

Set the wiper at the original position.

- Insert the wiper by holding both ends of the wiper.

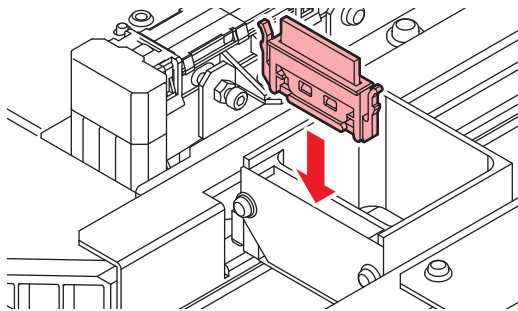

10

Clean the cap rubber and cap rubber cover.

- Wipe off the ink sticking to the cap rubber and cap rubber cover with a clean stick dipped in cleaning solution for maintenance. Wipe off so that cleaning solution for maintenance will not remain.

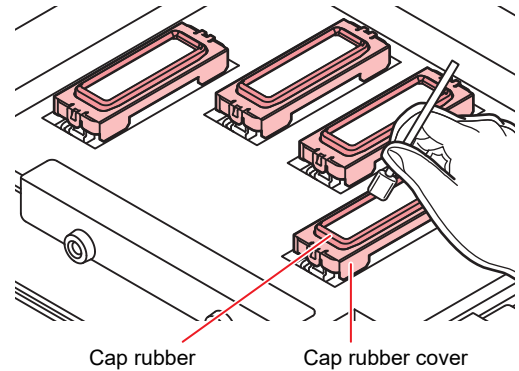

11

Close the right side maintenance cover then press the **ENTER key.**

- After its initial operation, the machine returns to step1.

Performing the Station without [FUNC2] (TEST PRINT/CLEANING) key

You can select Station by using the [FUNC1] (MENU) key in the Local without pressing the [FUNC2] (TEST PRINT/CLEANING) key.

- (1) Press the [FUNC1] (MENU) key in Local.
- (2) Press [▲][▼] to select "Maintenance", and press the [ENTER] key.
- (3) Press [▲][▼] to select "Station", and press the [ENTER] key.
 - The Station MENU appears. Then proceed to step 3.

Washing the Ink Discharge Passage

Wash the ink discharge passage on a regular basis (once every 2 - 3 months) to prevent ink coagulation from clogging the passage.

1 Press the **FUNC2** (TEST PRINT/CLEANING), and press the **ENTER** key in Local.

2 Press **▲▼** to select "Station", and press the **ENTER** key.

- The Station MENU appears.

3 Press **▲▼** to select "Pump Tube Wash", and press the **ENTER** key.

- Press the [ENTER] key in the Execution Check screen, and the carriage moves over the platen.
- Dry suction operation is performed repeatedly until the washing work is completed.

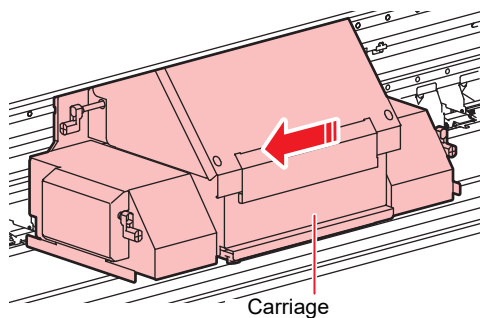

4 Open the right side maintenance cover.

- (1) Rotate the screws under the right side maintenance cover (for two positions) to the left and remove them.
- (2) Hold the bottom of the right side maintenance cover and pull it to the front.
- (3) While pulling the right side maintenance cover downward, remove it.

- If the right side maintenance cover is hard to remove, use the supplied screwdriver.

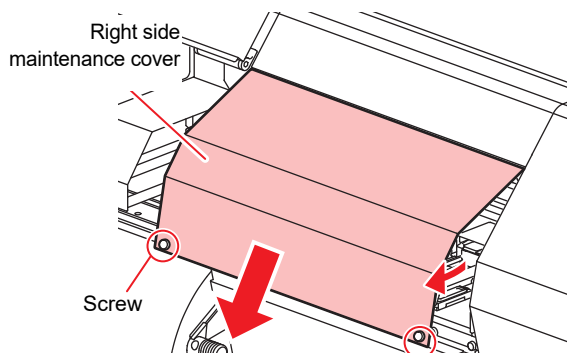

5 Suction the cleaning solution into a syringe and squirt about three syringes worth of solution into each cap.

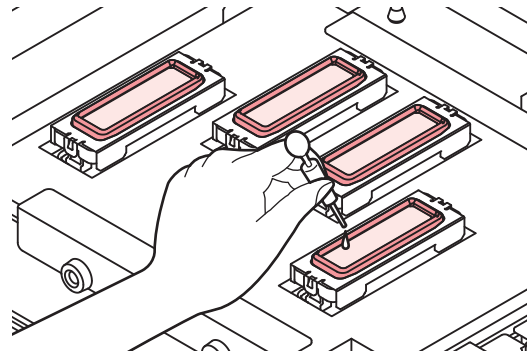

6 Close the right side maintenance cover and press the **ENTER** key.

- After running a dry suction for a certain period of time, the screen returns to step 2.

When the Machine Is Not Used for a Long Time (Custody Wash)

When the machine is not going to be used for a week or more, use the cleaning function for custody to clean the head nozzles and ink discharge passage. After this, keep the machine in custody.

Check the items on the right beforehand.

Is [NEAR END] or [INK END] displayed?

- The cleaning solution or ink is absorbed when the nozzles are washed.
- At this time, if the state of "no ink" or "almost no ink" is detected, the nozzle washing operation cannot start.
- Refill ink.

Important! • Be sure to use the dedicated washing liquid for maintenance (SPC-0568).

1 Press the **[FUNC2]** (TEST PRINT/CLEANING), and press the **[ENTER]** key in Local.

2 Press **[▲]** **[▼]** to select "Station", and press the **[ENTER]** key.

- The Station MENU appears.

3 Press **[▲]** **[▼]** to select "Custody Wash", and press the **[ENTER]** key.

- Press the [ENTER] key in the Execution Check screen, and the carriage moves over the platen.

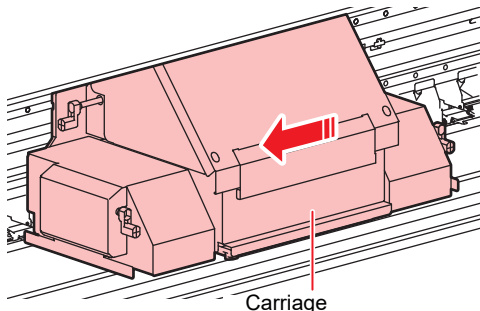

Important! • Until wiper/ bracket cleaning is completed, [Please clean the wiper.] is displayed on the screen. After the work up to the step 5 is completed, press the [ENTER] key.

4 Open the right side maintenance cover.

- (1) Rotate the screws under the right side maintenance cover (for two positions) to the left and remove them.
- (2) Hold the bottom of the right side maintenance cover and pull it to the front.
- (3) While pulling the right side maintenance cover downward, remove it.

- If the right side maintenance cover is hard to remove, use the supplied screwdriver.

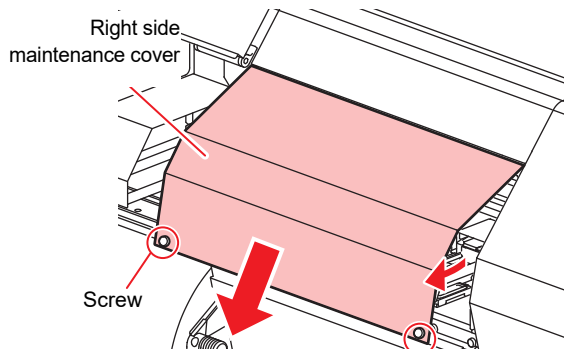

5 Clean the wiper and the bracket, and press the [ENTER] key.

- (1) Open the right maintenance cover then pull out it by holding projections at both ends of the wiper.
- (2) Clean the wiper and bracket with a clean stick dipped in maintenance washing liquid for maintenance. (SPC-0568: Washing liquid for maintenance)
 - Wipe off so that maintenance washing liquid for maintenance will not remain.
- (3) Insert it in the original position by holding the projections at both ends of the wiper.

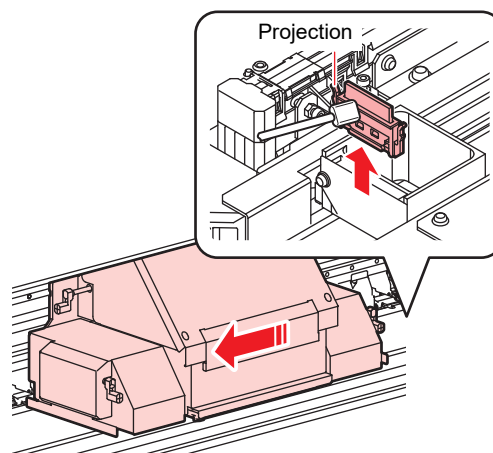

6 Clean the cap rubber and cap rubber cover and press the **ENTER** key.

- Wipe off the ink sticking to the cap rubber and cap rubber cover with a clean stick dipped in cleaning solution for maintenance. Wipe off so that cleaning solution for maintenance will not remain.
- At this time, the discharge passage is cleaned automatically.

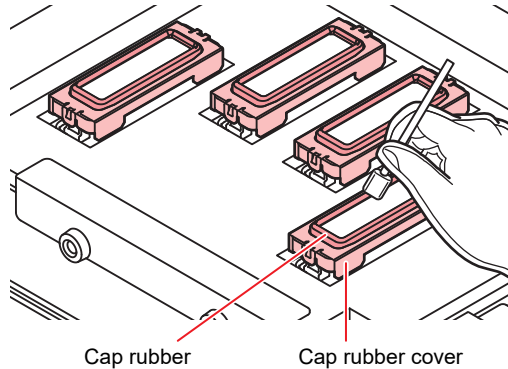

7 Fill up the cap with cleaning solution for maintenance, using a dropper.

- Fill the cap with the cleaning solution just before the solution overflows from the cap.

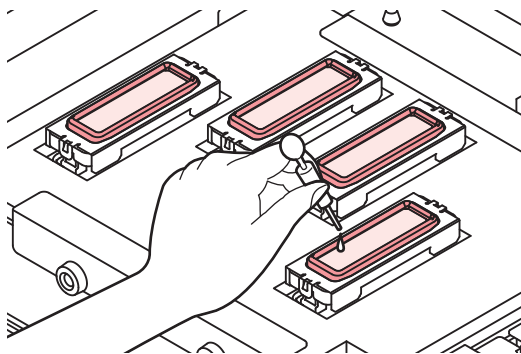

- Important!** • Until washing liquid is filled, [Fill the liquid.] is displayed on the screen.

8 Press **▲** **▼** to enter the leaving time. (Supported from firmware version 2.6 onward)

9 Close the right maintenance cover, and press the **ENTER** key.

- The nozzles are washed.
- When the nozzles have been completely washed, the head moves onto the platen.

10 Suction the cleaning solution into a syringe and squirt about three syringes worth of solution into each cap.

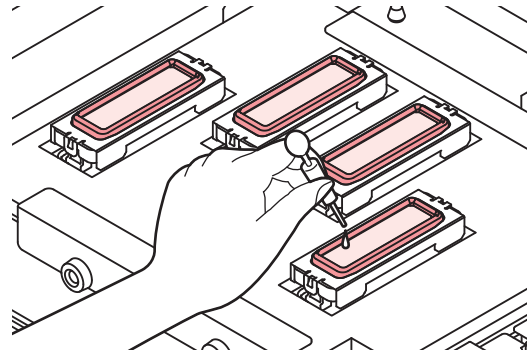

11 Close the right side maintenance cover and press the **ENTER** key.

- After the idle absorbing operation has been performed for 30 seconds, the screen returns to step2.

Cleaning the Ink Head and the Area around It

Because the ink head employs a very precise mechanism, due care needs to be taken when it is cleaned.

Using a clean stick, etc., rub off gelatinous ink or dust that may stick to the lower part of the slider and the area around the ink head. In doing so, never rub the nozzles of the head.

Tools required for cleaning

• Clean stick (SPC-0527)	• Gloves
• Safety glasses	



- Be sure to wear the attached safety glasses and gloves when cleaning the area around the ink head. Otherwise, you may get ink in your eyes.
- The ink contains organic solvent. If you get the ink on your skin or in your eyes, wash it away with plenty of water immediately.

1 Press the **FUNC2** (TEST PRINT/CLEANING), and press the **ENTER** key in Local.

2 Press **▲▼** to select “Station”, and press the **ENTER** key.

- The Station MENU appears.

3 Press **▲▼** to select “CARRIAGE OUT”, and press the **ENTER** key.

4 Press **▲▼** to select “HEAD MAINTENANCE”, and press the **ENTER** key.

- Press the [ENTER] key in the Execution Check screen, and the carriage moves to the left end of this machine.

5 Remove the left side maintenance cover.

(1) Rotate the screws under the left side maintenance cover (for three positions) to the left and remove them.

(2) Hold the bottom of the left maintenance cover, and pull the cover toward you from below to remove the cover.

- If the left side maintenance cover is hard to remove, use the supplied screwdriver.

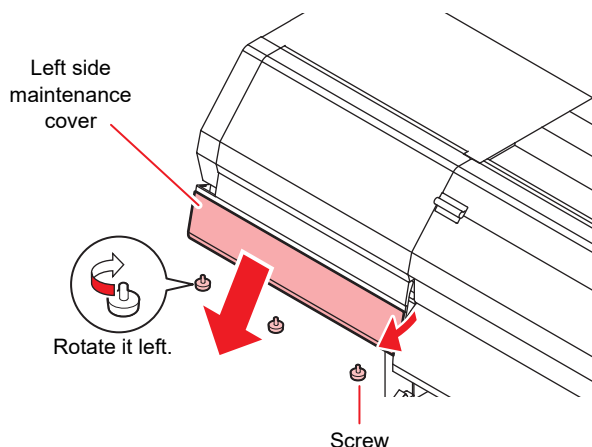

6 Wipe ink sticking to the side of the head off with a clean stick.

- Never rub the nozzles.

Clean the side surface of the head (shown in deep gray) with a clean stick.

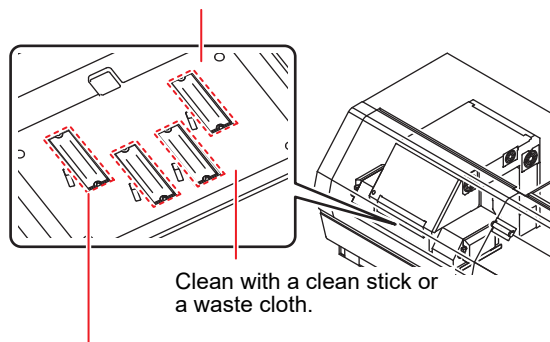

The nozzle part (Never touch it.)

7 Clean the bottom surface of the UV lamp.

- If there is any ink stuck on the rear side of the bottom surface of the UV lamp, apply the cleaning solution for maintenance to a clean stick and wipe the ink away.

Wipe off so that cleaning solution for maintenance will not remain.



- When cleaning, do not rub forcefully. Doing so can damage UV lamps.

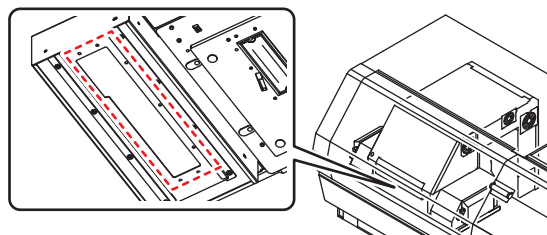

8 After the cleaning, close the left side maintenance cover then press the **ENTER** key.

- After its initial operation, the machine returns to Local.

When nozzle missing Cannot Be Solved

When nozzle missing cannot be solved even after the head cleaning (☞ P.2-23) has been done, perform the following three functions:

Nozzle Wash	• Wash the head nozzle. (☞ P.4-13)
Nozzle Recovery	• Alternative nozzles for printing, when nozzles missing can not be improved. (☞ P.4-14)
Sub Tank	• Fill the head with ink. (☞ P.5-4)

Washing the Head Nozzle

Perform cleaning of the nozzles in the heads to prevent them being clogged with coagulated ink.

1 Press the **FUNC2** (TEST PRINT/CLEANING), and press the **ENTER** key in Local.

2 Press **▲▼** to select “Station”, and press the **ENTER** key.

- The Station MENU appears.

3 Press **▲▼** to select “Nozzle Wash”, and press the **ENTER** key.

- Press the [ENTER] key in the Execution Check screen, and the carriage moves over the platen.

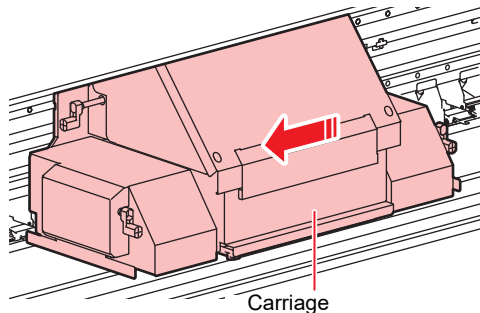

4 Open the right side maintenance cover.

- (1) Rotate the screws under the right side maintenance cover (for two positions) to the left and remove them.
- (2) Hold the bottom of the right side maintenance cover and pull it to the front.
- (3) While pulling the right side maintenance cover downward, remove it.

- If the right side maintenance cover is hard to remove, use the supplied screwdriver.

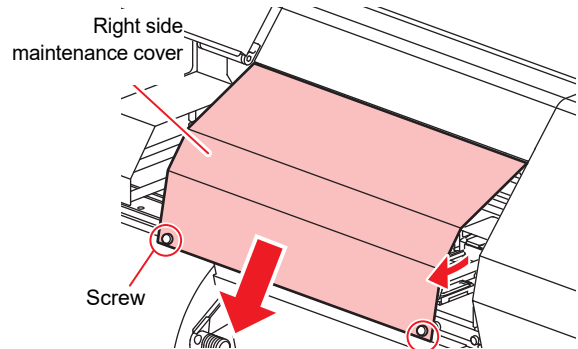

5 Clean the wiper and the bracket, and press the **ENTER** key.

- (1) Pull out it by holding projections at both ends of the wiper.
- (2) Clean the wiper and bracket with a clean stick dipped in maintenance washing liquid for maintenance. (SPC-0568: Washing liquid for maintenance)
 - Wipe off so that maintenance washing liquid for maintenance will not remain.
- (3) Insert it in the original position by holding the projections at both ends of the wiper.

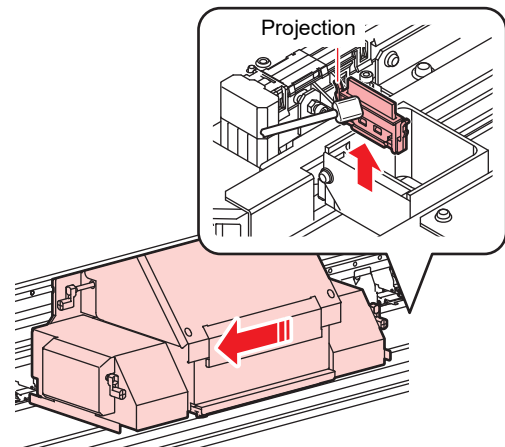

6 Clean the cap rubber, and press the **ENTER** key.

- Wipe off the ink sticking to the cap rubber with a clean stick dipped in maintenance washing liquid for maintenance.
- Wipe off so that maintenance washing liquid for maintenance will not remain.
- At this time, the discharge passage is cleaned automatically.

- 7** Fill up the cap with cleaning solution for maintenance, using a dropper.
- Fill the cap with the cleaning solution just before the solution overflows from the cap.

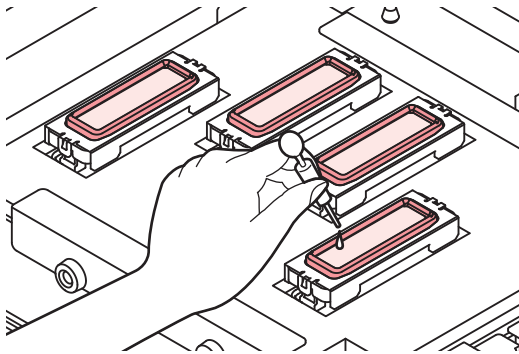

- 8** Press **▲▼** to enter the leaving time. (Supported from firmware version 2.6 onward)

- 9** Close the right side maintenance cover and press the **ENTER** key.

- Perform the capping operation and wait specified time.
- The display provides a countdown display.
- When the resting time has passed, the machine absorbs the cleaning solution filled in the cap, and performs cleaning. Then the machine returns to the display in step 2.

Important! • When nozzle missing is not cleared even after this washing is carried out several times, contact your local distributor, our sales office or our call center.

Nozzle Recovery Function

Nozzle Recovery: When nozzles missing can not be improved at specific points, other good nozzles can be used as alternatives for printing.

Print the nozzle pattern

Used to print a pattern and to check and/or register clogged nozzles.

- 1** Press the **FUNC1** (MENU) in Local.
- 2** Press **▲▼** to select “Maintenance”, and press the **ENTER** key.
 - Maintenance MENU appears.
- 3** Press **▲▼** to select “Nozzle Recovery”, and press the **ENTER** key.
- 4** Press the **ENTER** key.

- 5** Press **▲▼** to select desired head(s) (H1-2/H3-4), and press the **ENTER** key.

- 6** Press the **ENTER** key twice.
- Printing of the nozzle pattern will start.
 - Select “ENTRY” then “Move to select of the Nozzle line (Step 5) without drawing a pattern”

Overhead view (4-colors inkset)

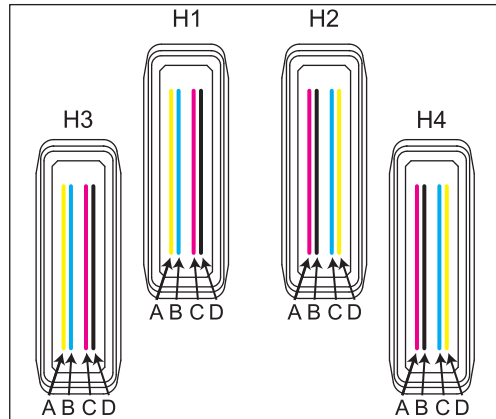

Nozzle pattern of Head 1 and 2(4-colors inkset)

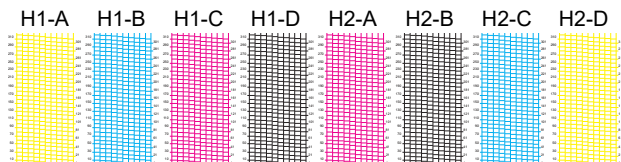

Important! • Set a media of more than 210mm put horizontally. If a media with narrow width is set, printing will only be conducted to midway.

- 7** Select the Nozzle line that needs Nozzle Recovery by pressing **▲▼**, and press **ENTER** key.

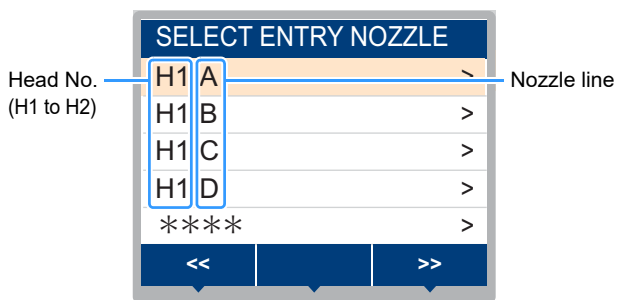

8 Register the Nozzle number that needs Nozzle Recovery and then press **[ENTER]** key.

- (1) Select the registration number from 1 to 10 by pressing **[▲][▼]** key and press the **[ENTER]** key.
- (2) Register the nozzle number that needs recovery by pressing **[▲][▼]** key and press the **[ENTER]** key.

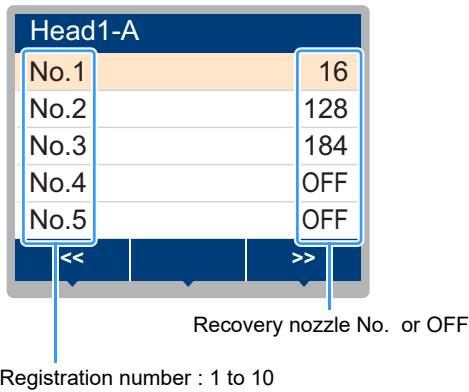

Example of nozzle to be recovered

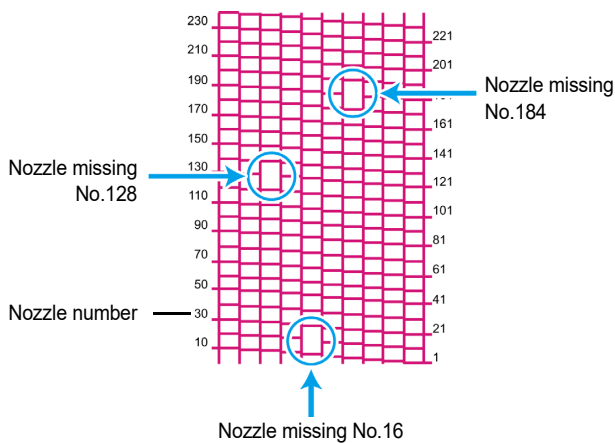

Registration number	Recovery Nozzle No.	State
1	16	Target for nozzle recovery
2	128	Target for nozzle recovery
3	184	Target for nozzle recovery
4	OFF	No registration
5	OFF	No registration

9 Press the **[END/POWER]** key several times to end the setting.

Important!

- Up to 10 nozzles can be registered per 1 nozzle line.
- Even if you use this function, time required for drawing does not change.
- The nozzle recovery is not reflected if printing is performed under the following conditions:

4-colors inkset

Resolution	Pass	Scan speed
300x600	2 pass	Normal

6-colors + White inkset

Resolution	Pass	Scan speed
300x600	4 pass	Normal
300x600	6 pass	Normal

Check the print condition for which nozzle recovery cannot be performed

Depending on the nozzle registered, there is the mode not reflected by "RECOVERY". Check the unrecoverable print conditions with the check function.

Important!

- If there are many registered nozzles, it takes time to display the check result.

1 Press the **[FUNC1]** (**MENU**) in Local.

2 Press **[▲][▼]** to select "Maintenance", and press the **[ENTER]** key.

- Maintenance MENU appears.

3 Press **[▲][▼]** to select "Nozzle Recovery", and press the **[ENTER]** key.

4 Press **[▲][▼]** to select "CHECK", and press the **[ENTER]** key.

- The mode for which nozzle recovery is invalid is displayed.
- If there is no mode for which nozzle recovery is invalid, "NONE" is displayed.

5 Press the **[END/POWER]** key several times to end the setting.

Clear the set value

- 1 Press the **FUNC1** (MENU) in Local.
- 2 Press **▲▼** to select “Maintenance”, and press the **ENTER** key.
 - Maintenance MENU appears.
- 3 Press **▲▼** to select “Nozzle Recovery”, and press the **ENTER** key.
- 4 Press **▲▼** to select “CLEAR”, and press the **ENTER** key.
- 5 Press **▲▼** and **FUNC1** (>>) **FUNC3** (<<) to select the Nozzle line that need clear, and press the **ENTER** key.
 - A clearconfirmation message appears.
- 6 Press the **ENTER** key.
- 7 Press the **END/POWER** key several times to end the setting.

Automatic Maintenance Function

To use this machine comfortably, you can set various maintenances to be performed automatically. Here, set performing intervals of various automatic maintenances.

You can prevent troubles such as ink clogging by performing automatic maintenance periodically (automatic maintenance function).

For the Auto Maint. functions, the following items can be set:

- Important!**
- When you perform maintenance manually, after manual maintenance is completed and when time set with the automatic maintenance function has passed, maintenance starts automatically.

Function name	Descriptions
Refresh	Sets the refresh level.
Cleaning	Sets the head cleaning level.
Cleaning (White)	Sets the head cleaning level for white ink.

- Important!**
- If an ink tank error occurs, the operation set by the Automatic Maintenance function is not performed. Release the error. (☞ P.5-13)
 - During the execution of automatic maintenance, ink flows into the waste ink tank. Check the amount of ink in the waste ink tank every day, and discard the ink if necessary. (☞ P.4-18)

Setting the Refreshing level

For nozzle clogging prevention, set the amount of some ink to be discharged from the nozzle.

- 1 Press the **FUNC1** (MENU) in Local.
- 2 Press **▲▼** to select “Maintenance”, and press the **ENTER** key.
 - Maintenance MENU appears.
- 3 Press **▲▼** to select “Auto Maint.”, and press the **ENTER** key.
- 4 Press the **ENTER** key.
 - “Refresh” will be selected.
- 5 Press **▲▼** to set the refresh level, and press the **ENTER** key.
 - Set value : OFF/Lv.1/Lv.2/Lv.3
- 6 Press the **END/POWER** key several times to end the setting.

Setting the Cleaning level

The head cleaning level is set.

- 1 Press the **FUNC1** (MENU) in Local.
- 2 Press **▲▼** to select "Maintenance", and press the **ENTER** key.
 - Maintenance MENU appears.
- 3 Press **▲▼** to select "Auto Maint.", and press the **ENTER** key.
- 4 Press **▲▼** to select "Cleaning", and press the **ENTER** key.
- 5 Press **▲▼** to select the cleaning level, and press the **ENTER** key.
 - Set value : OFF/Lv.1/Lv.2/Lv.3
- 6 Press **▲▼** to select the cleaning type, and press the **ENTER** key.
 - Set value : Soft/ Normal/ Hard
- 7 Press the **END/POWER** key several times to end the setting.

Setting the Cleaning level for White ink

Set a head cleaning level for white ink.

- Important!**
- This setting is displayed only when filling white ink in the ink tank.
 - If the timing of normal "Auto Maintenance - Cleaning" coincides with the timing of "Auto Maintenance - Cleaning (White)" for white ink, normal "Automatic Maintenance - Cleaning" is performed.
Note, however, that the cleaning type setting is compared between normal cleaning and white ink cleaning, and the harder of the two is used as the cleaning type. (If "Soft" is set for normal cleaning and "Normal" is set for white ink cleaning, "Normal" cleaning is performed.)

- 1 Press the **FUNC1** (MENU) in Local.
- 2 Press **▲▼** to select "Maintenance", and press the **ENTER** key.
 - Maintenance MENU appears.
- 3 Press **▲▼** to select "Auto Maint.", and press the **ENTER** key.

- 4 Press **▲▼** to select "Cleaning (White)", and press the **ENTER** key.
- 5 Press **▲▼** to select the cleaning level, and press the **ENTER** key.
 - Set value : OFF/Lv.1/Lv.2/Lv.3
- 6 Press **▲▼** to select the cleaning type, and press the **ENTER** key.
 - Set value : Soft/ Normal/ Hard
- 7 Press the **END/POWER** key several times to end the setting.

About white ink circulation function

This machine performs ink circulation automatically to prevent white ink pigment from settling out.

Display indication during white

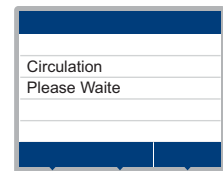

- Important!**
- White ink circulation function is performed automatically only when you use 4 colors + white ink set.
 - Even if you perform white circulation, ink is not consumed.
 - When this machine does not perform the printing operation etc., white circulation is performed once one hour.
 - If you stop white circulation on the way, press the **[END/POWER]** key.
 - When white circulation operation has been completed, the display returns to the status before starting white circulation.
 - When the machine receives printing data during white circulation, it stops white circulation and the display returns to the status before starting white circulation.
 - This machine is automatically started up and white circulation is performed even if the printer power is turned off.

Discarding waste ink

(4) Press [ENTER] key



- Discard waste ink frequently. If left for a long time, the ink in the waste ink tank may be cured or overflow.
- When disposing of the waste ink, be sure to wear attached safety glasses and gloves to perform the work. Otherwise, you may get ink in your eyes.
- If you get the ink on your skin or in your eyes, wash it away with plenty of water immediately.

1

Remove the waste ink tank.

- Pull out the tube inserted into the waste ink tank, and take out the waste ink tank.

Important!

- When pulling out the tube, ink may drop from the tip of the tube. Wipe the tube with waste cloth and cover the tip before starting work.

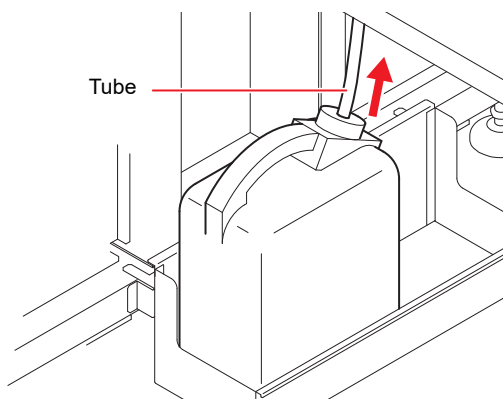

2

Replace the waste ink tank.

- Prepare a new waste ink tank.



- Request the treatment of waste ink for an industrial waste disposal contractor.
- A part of the ingredients (photo polymerization initiator) has toxicity against aquatic organisms. Please prevent leakage flow to natural water systems (river, etc.) and domestic sewages (toilet, road, etc.)

3

Return the empty waste ink tank to the original position.

- Reinsert the tube pulled out.

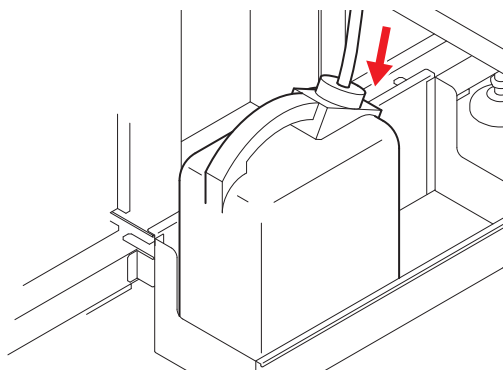

4

Reset the waste ink counter.

- (1) Press [SEL] key twice to display the (WASTE INK) to [FUNC2]
- (2) Press [FUNC2] (WASTE INK)
- (3) Press [FUNC2] (RESET)

For waste ink remaining management

In this machine informing the remaining amount of the waste ink tank (as a guide) on the display.

Local <Setup 1>

3200mm

PRE

30°C/40°C

M
C
Y
K

MENU
TEST PRINT / CLEANING
REMOTE

Amount of waste ink	
	0-9% of the waste ink has accumulated in the tank
	10-29% of the waste ink has accumulated in the tank
	30-49% of the waste ink has accumulated in the tank
	50-69% (NEAR FULL) Waste ink is nearly full. Recommend to discard as soon as possible.
	70%- (FULL) Waste ink tank is full. Dispose waste ink promptly.

For the operation limitation by the amount of waste ink

According to the amount of waste ink that has accumulated in the waste ink tank, there are items that will not be able to operate in this machine.

Discarding waste ink diligently is recommended.

Error Message	Operation restriction	Solution
	No	It can be used as they are, but waste ink tank would be immediately full. Dispose the waste ink as soon as possible. Dispose of waste ink according to regional laws and regulations.
	Following operations will not be activated. <ul style="list-style-type: none"> Operation using ink Print Remote transition If occurs during printing, transit to local after printing completion 	Emptying the waste ink tank referring to the manual Chapter 4 "Discarding waste ink" Then, please reset the waste ink tank. Dispose of waste ink according to regional laws and regulations.

Adjust the waste ink

Amount of waste ink that is displayed on the display is only a "guideline".

The amount may be different from the amount actually accumulated.

- 1
 Press **SEL** key twice to display the (WASTE INK TANK) to [FUNC2]
- 2
 Press **FUNC2** (WASTE INK TANK)
- 3
 Press **▲ ▼** to adjust the amount of waste ink
 - Adjust to match the actual amount of waste ink.

	Set to 0%
	Set to 10%
	Set to 30%
	Set to 50%
	Set to 70%

- 4
 Press **ENTER** key

Replacing consumables

Replacing the wiper

The wiper is consumable. When the warning message "Replace a WIPER" is displayed, it is necessary to replace the wiper, immediately replace the wiper with a new one.

Also, wipe ink sticking to the lower surface of the wiper cleaner off.

- Important!** • A cleaning wiper (SPA-0193) is an option. Buy one through the dealer in your region or at our service office.

1 Press the **FUNC2** (TEST PRINT/CLEANING) in Local.

2 Press the **ENTER** key.

3 Press **▲▼** to select "Station", and press the **ENTER** key.

4 Press **▲▼** to select "Replace Wiper", and press the **ENTER** key.

5 Press the **ENTER** key.

- The carriage moves onto the platen.
- The number of times when the wiper was used is reset.

- Important!** • Until the replacement work is completed, [COMPLETED] is displayed on the screen. After the work up to the Step 3 is completed and you close the right side maintenance cover, press the [ENTER] key.

6 Open the right maintenance cover then remove the wiper.

- Pull out the wiper by holding the protrusions at its both ends.

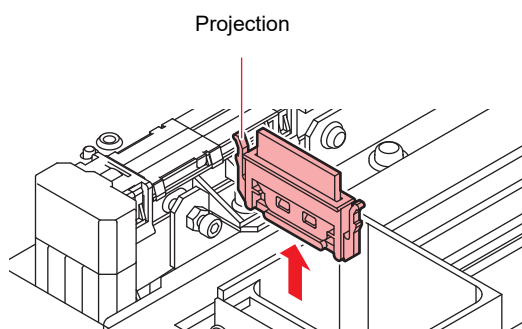

7 Insert a new wiper.

- Insert a new wiper by holding its both ends.
- There is no direction to the wipers. They can be inserted with either side facing forward.

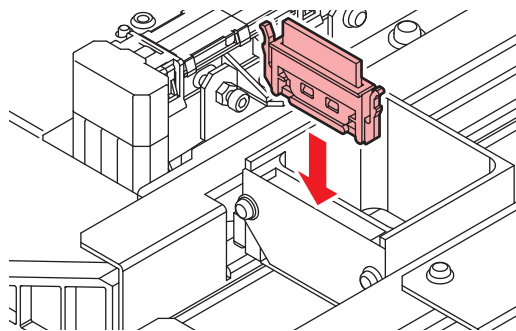

8 Close the right side maintenance cover and press the **ENTER** key.

- After its initial operation, the machine returns to Local.

Replacing the Mist Fan Filter (H fan filter)

Replace it once a month.

1 Press the **FUNC2** (TEST PRINT/CLEANING), and press the **ENTER** key in Local.

2 Press **▲▼** to select "Station", and press the **ENTER** key.

- The Station MENU appears.

3 Press **▲▼** to select "CARRIAGE OUT", and press the **ENTER** key twice.

- The carriage moves onto the platen.

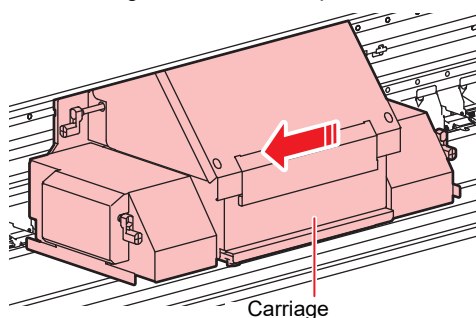

4 Open the right side maintenance cover.

- (1) Rotate the screws under the right side maintenance cover (for two positions) to the left and remove them.
- (2) Hold the bottom of the right side maintenance cover and pull it to the front.
- (3) While pulling the right side maintenance cover downward, remove it.

- If the right side maintenance cover is hard to remove, use the supplied screwdriver.

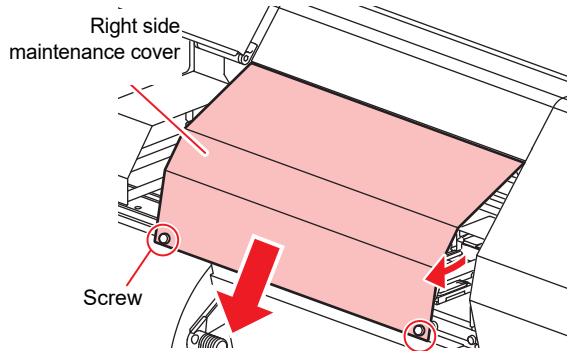
**5** Remove the H fan filter cover at the right side of the carriage.

- Remove the screw on the H fan filter cover before removing the cover.

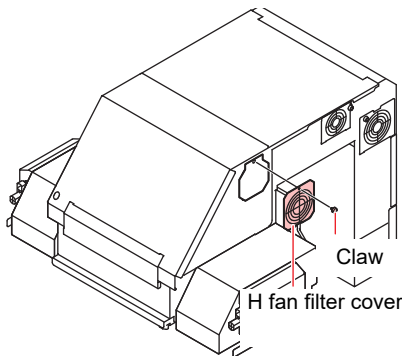
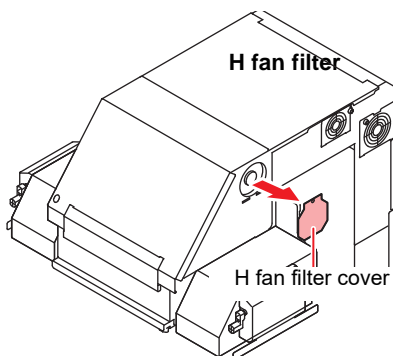
**6** Remove the used H fan filter cover.**7** Mount a new H fan filter (SPC-0766).

- Align the hole in the H fan filter with the screw hole.

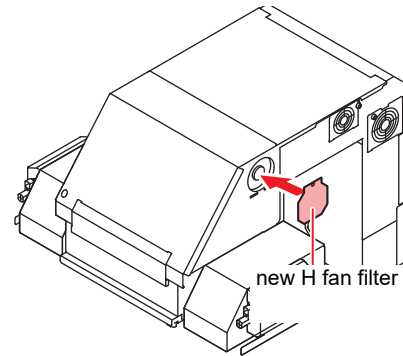
**8** Return the H fan filter cover to the original status.**9** Close the right side maintenance cover, and press the **ENTER** key.**Important!**

- Ink at printing adheres to the H fan filter ASSY. When replacing the filter, it is recommended to perform the work with a sheet of paper placed.

Replace the ink tank and ink filter

To keep the ink in good quality in the ink tank, you need to replace the ink tank annually. When an appropriate warning message appears, be sure to replace the ink tank (SPA-0285) and ink filter (SPA-0286) in the following procedure:



- Be sure to wear the accompanying gloves and protective safety glasses before working. The ink may get in your eyes.

1 Press the **FUNC1** (MENU) in LOCAL.

2 Press **▲▼** to select [Maintenance], and press the **ENTER** key.

3 Press **▲▼** to select [Replace Ink Tank], and press the **ENTER** key.

4 Press **▲▼** to select a desired ink tank, and press the **ENTER** key.

- The display shows a confirmation screen prompting to replace the ink tank and the type and the expiration date (year and month) of the ink contained in the ink tank to be replaced.

5 If there is no problem on the confirmation screen, press the **ENTER** key.

- This resets the ink charge information embedded in this machine.

6 Remove the ink maintenance cover for the ink tank selected in step 4.

- Remove the screws (7 places) that is attached to the ink tank cover, and remove the cover.

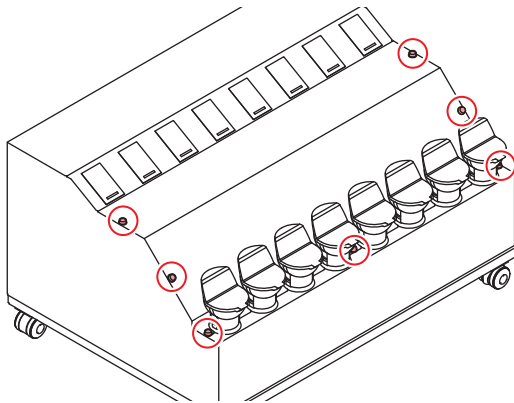

7 Replace the ink tank.

- Cover the surrounding area with waste cloth for protection against dirt before changing the ink tank.

(1) Remove the ink filter attached to the ink tank.

- Loosen the joints on the top and bottom of the ink filter, and remove the filter.

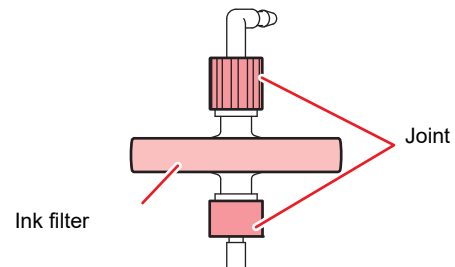

(2) Remove the ink tank.

- Take care not to tilt the ink tank greatly when removing the tank. It may cause ink leakage from the cap.

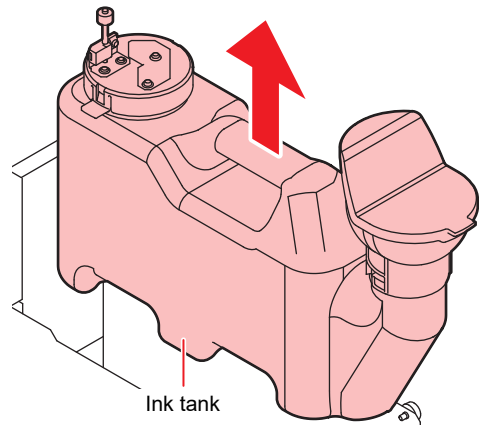

(3) Press the protrusion on the lid of the ink tank and raise a new ink tank.

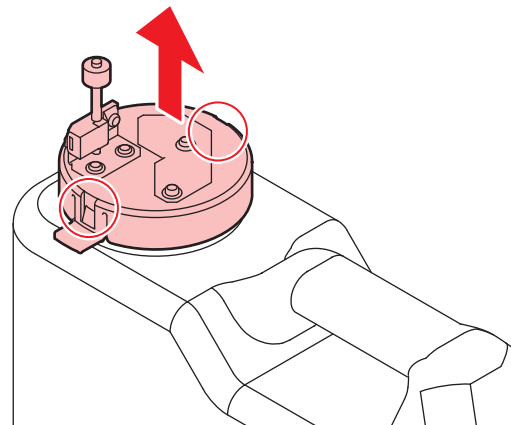

(4) Set a new ink tank, and mount the ink filter.

- Tighten the joints on the top and bottom of the ink filter.

8

Replace the white ink tank.

- Cover the surrounding area with waste cloth for protection against dirt before changing the ink tank.

(1) Remove the motor's connector.

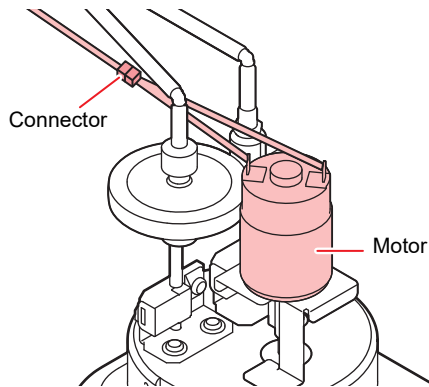

(2) Remove the ink filter attached to the ink tank.

- Loosen the joints on the top of the ink filter, and remove the filter.

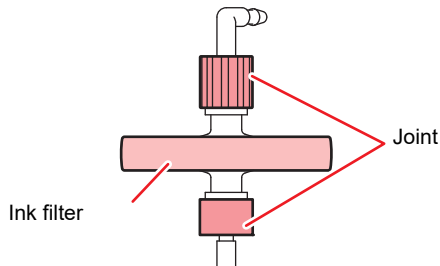

(3) Remove the joint attached to the side of ink filter.

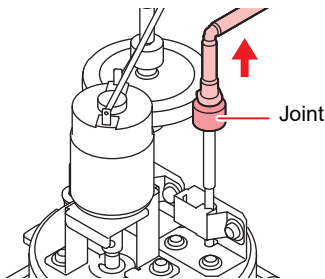

(4) Set a new ink tank, and mount the ink filter.

- Tighten the joints on the top of the ink filter.



Caution

- Do not tighten the joint too much. Otherwise, the filter might be damaged. Be careful.
- Do not pour the ink remaining in the removed ink tank into the new tank.
- Request that an industrial waste disposal company process the disposal ink.

9

Refer to "Fill ink in the ink tank and charging" on P.1-11, and refill with new ink.

Tank Calibration

This machine manages the remaining amount of ink with the weight balance that is built in the ink supply unit.

If there is a difference between the remaining amount of ink displayed on the upper part of ink supply unit and the actual ink remaining amount, or when the error message "INKTNK SENS" has occurred, please perform the following tasks.

Method for correcting the weight balance

There are two types of correction method for the weight balance.

Normal	Using a 1kg wight, you can correct in high accuracy.
Adjust Zero Pos.	You can correct without using a weight. The correction work is carried out easily but less accurate than the adjustment in the "Normal".

Correct by the correction method "Normal"

1 Press the **(FUNC1)** (MENU) in LOCAL.

2 Press **(▲)** **(▼)** to select "Maintenance" and press the **(ENTER)** key.

3 Press the **(FUNC3)** (>>).

4 Press **(▲)** **(▼)** to select "Tank Calibration", and press the **(ENTER)** key.

5 Press **(▲)** **(▼)** to select "Normal" and press the **(ENTER)** key.

6 Press **(▲)** **(▼)** to select an ink tank (ink color) to be corrected, and press the **(ENTER)** key.

7 Remove the ink tank cover.

- remove the screws (7 places) that is attached to the ink tank cover, and remove the cover.

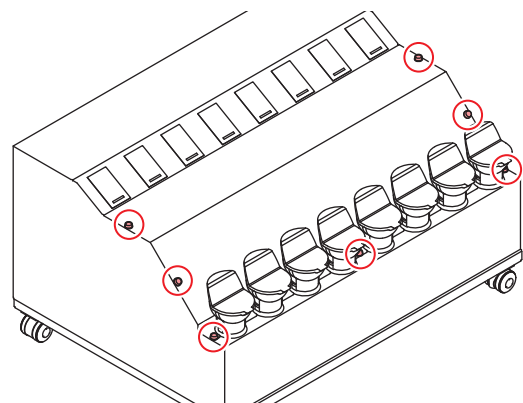

4

8 Remove the ink tank of the selected slot and press the **ENTER** key.

- (1) Remove the ink filter attached to the ink tank.
- Loosen the joints on the top of the ink filter, and remove the filter.

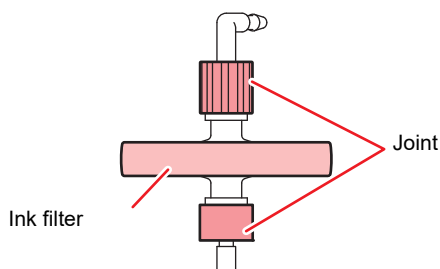

- (2) Tilt the ink tank to the front and remove.

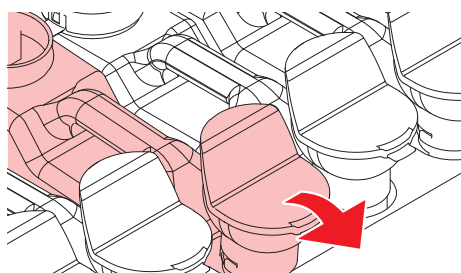

9 Place the 1kg weight on the dish of the balance of selected slot and press the **ENTER** key.

- Process the correction.

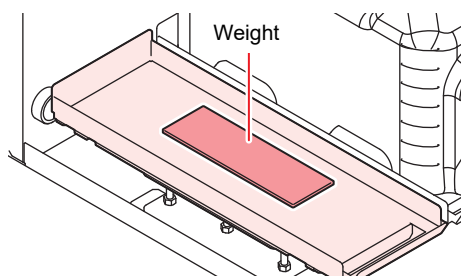

Important!

- Please put the weight in the center of the dish of the balance. If you put weight on the edge of the dish, it will cause to increase the error of the remaining amount detection.
- During the correction process, please do not give vibration to the ink supply unit. There is a possibility to fail the correction process.
- When the correction process fails, "Failed" will be shown on the display. Press the [ENTER] or [END] key, and change the position or the load of the weight.

10 When the correction processing is finished successfully, remove all the weights on the dish of the balance and press the **ENTER** key.

- Perform the correction processing without the weight on the balance.

Important!

- During the correction process, please do not give vibration to the ink supply unit. There is a possibility to fail the correction process.
- When the correction process fails, "Failed" will be shown on the display. Press the [ENTER] or [END] key to clear the error display and press again the [ENTER] key. It will resume the correction processing.

11 When the correction processing is finished successfully, set the ink tank that was removed in step 8 and press the **ENTER** key.

Correct by the correction method "Adjust Zero Pos."

1 Press the **FUNC1** (MENU) in LOCAL.

2 Press **▲▼** to select "Maintenance", and press the **ENTER** key.

3 Press the **FUNC3** (>>).

4 Press **▲▼** to select "Tank Calibration", and press the **ENTER** key.

5 Press **▲▼** to select "Adjust Zero Pos." and press the **ENTER** key.

6 Press **▲▼** to select an ink tank (ink color) to be corrected, and press the **ENTER** key.

7 Remove the ink tank of the selected slot and press the **ENTER** key.

- Perform the correction processing without the weight on the balance.

Important!

- During the correction process, please do not give vibration to the ink supply unit. There is a possibility to fail the correction process.
- When the correction process fails, "Failed" will be shown on the display. Press the [ENTER] or [END] key to clear the error display and press again the [ENTER] key. It will resume the correction processing.

8 When the correction processing is finished successfully, set the ink tank that was removed in step 7 and press the **ENTER** key.

Replacing the cap absorber

Replace once a year or when ink is adhering to approximately 50% of absorber surface.

1 Press the **FUNC2** (TEST PRINT/CLEANING), and press the **ENTER** key in Local.

2 Press **▲▼** to select "Station", and press the **ENTER** key.

- The Station MENU appears.

3 Press **▲▼** to select "CARRIAGE OUT", and press the **ENTER** key twice.

- The carriage moves onto the platen.

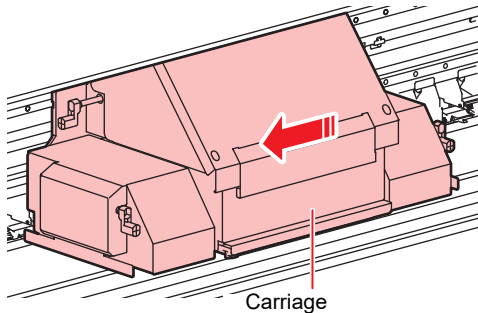

4 Open the right side maintenance cover.

(1) Rotate the screws under the right side maintenance cover (for two positions) to the left and remove them.

(2) Hold the bottom of the right side maintenance cover and pull it to the front.

(3) While pulling the right side maintenance cover downward, remove it.

- If the right side maintenance cover is hard to remove, use the supplied screwdriver.

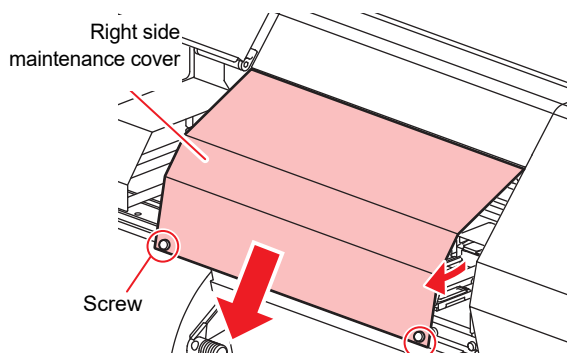

5 Remove the plates (front and rear) retaining the absorber.

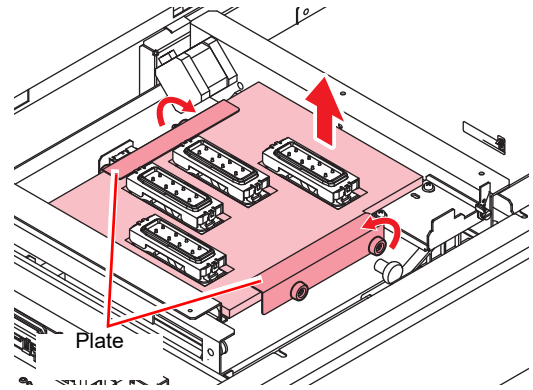

6 Install a new absorber.

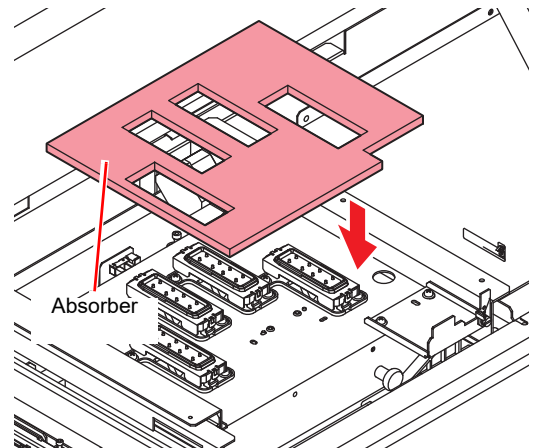

7 Tighten the screws while pressing in.

8 Close the right side maintenance cover, and press the **ENTER** key.

Refilling antifreeze mixed water

To cool the LED UV unit, put antifreeze mixed water into the cooling water tank in the cooling device.

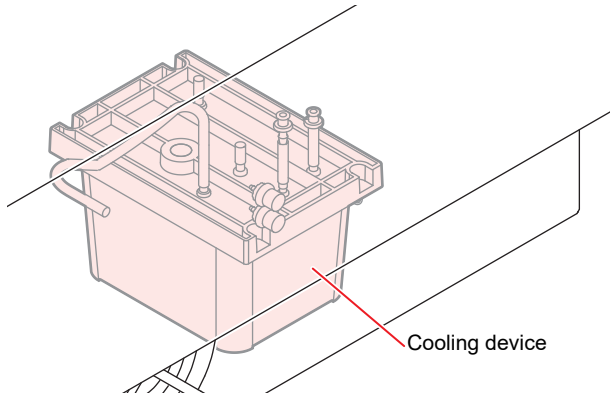

Note on refill



- When only water is supplied to the cooling water tank without antifreeze liquid, it may damage the UV unit by freeze.
- When only antifreeze liquid is supplied to the cooling water tank without water, the machine does not work properly, and may cause an error.
- If water in the cooling water tank frequently becomes insufficient, contact your local distributor, our sales office or our call center.



- Dispose of the waste water mixed with antifreeze liquid pursuant to the regulations of your district.

Note on antifreeze mixed water



To make mixed water, be sure to use the potable water meeting one of the following conditions:

- Calcium content: 1 mg/100 ml (10 mg/L) or less
- Hardness : 60 mg/L or less
- Distilled water (Purified water)
- Water and antifreeze liquid compound ratio should be 2(water) to 1(Antifreeze liquid). Or use our specialized antifreeze mixed water (SPC-0783).
- Use it within one week when you make mixed water. The mixed water that one week or more passed after it makes it is never used for this machine regardless of use/unused. Moreover, do not add to the mixed water newly made.

Precautions in handling the antifreeze liquid



- Be sure to wear goggle and gloves for handling the antifreeze liquid.



- Use the recommended antifreeze liquid (SPC-0394) by Mimaki. If not, the cooling device may be broken. (Supplied antifreeze liquid :1000cc x 2 bottles)
- Do not touch the antifreeze liquid directly. If the antifreeze liquid settles on your skin or clothes, immediately wash it off with soap and water. If you get antifreeze liquid in your eyes, immediately wash your eyes with a lot of clean water. Then, consult a doctor as soon as possible.
- Store antifreeze liquid in a dark and cold place.
- Store antifreeze liquid in a place that is out of the reach of children.
- When discarding antifreeze liquid which is no longer needed, entrust them to an industrial waste disposal contractor, clarifying their contents.
- Before using antifreeze liquid, be sure to read the Safety Data Sheet (SDS).



- Prepare a tank with a cap to put in the waste water from cooling water tank.
- When water in the cooling water tank is low, a warning message "WATER LACK" is displayed. In this case, refill water in the same way shown as the next page.

Refill antifreeze mixed water

If an error of lack of water, refill antifreeze mixed water. To fill up its capacity, about 200cc refill is required.

- 1 **Made mixed water (antifreeze liquid: 1, water: 2) in the attached reservoir and move it to the attached syringe.**



- 2 **Uncover the feed-water inlet and the air vent.**

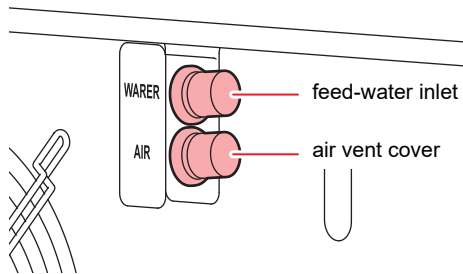

- 3 **Refill antifreeze mixed water.**

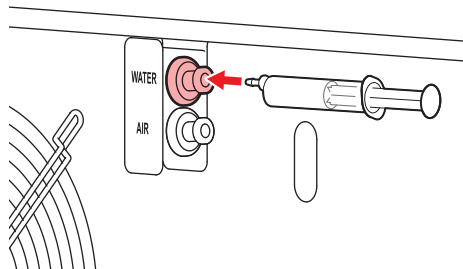

- Fill the antifreeze mixed water from the feed-water inlet.
- Fill it up seeing the water gauge on the back of this machine. Displaying red on the water gauge indicates full.

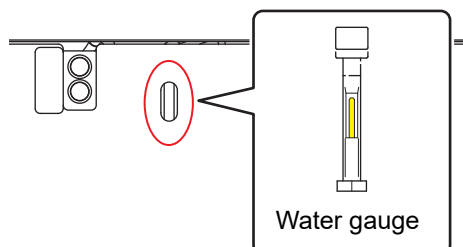

Important!

- Be aware that if you put in too much antifreeze mixed water, it may leak from the cooling water tank.

- 4 **Close the feed-water inlet and the air purge cover.**

Chapter 5

Troubleshooting



This chapter

describes the corrective measures to be taken for a phenomenon suspected to be trouble and the procedures to clear the error number displayed on the LCD.

Troubleshooting	5-3
Power does not turn on	5-3
The machine does not start printing	5-3
Media get jammed / media is soiled	5-4
Image quality is poor	5-4
Nozzle is clogged	5-4
Ink tank warning appears	5-5
When the ink leakage occurs	5-5
If an error related to the Sub Tank occurs (Error 618 to 61b).....	5-5
If nozzle missing due to color mixture of ink or aeration.....	5-6
When media heaves up at feeding	5-8
Warning / Error Messages	5-9
Warning messages	5-9
Error messages	5-14

Troubleshooting

Take appropriate actions as described below before taking the trouble as a failure.

If still the problem is not solved after troubleshooting, contact your dealer or an office of MIMAKI.

Power does not turn on

In most cases, this is due to improper connection of the power cable for the machine or computer. Check that the power cable is connected properly.

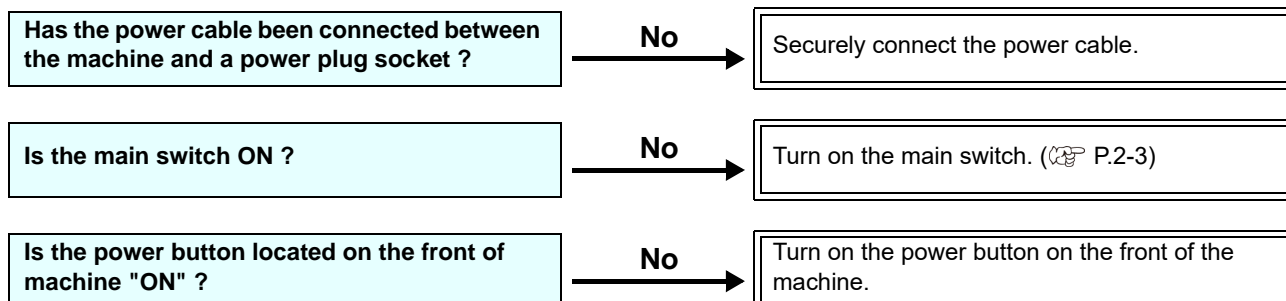

The machine does not start printing

This occurs when the data is not being transmitted to the machine properly.

It can also occur when the printing function does not work properly or the media is not set correctly.

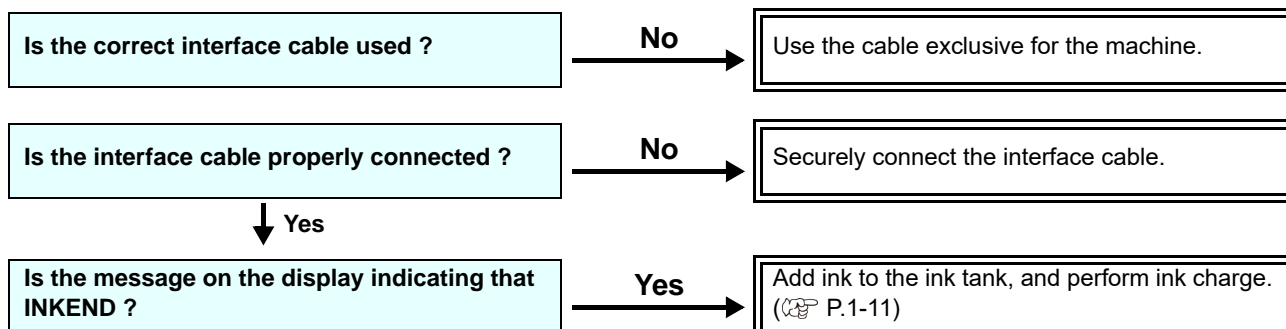

Media get jammed / media is soiled

Media jamming or stained media is considered to be due to the use of an unsuitable media or improper setting of media.

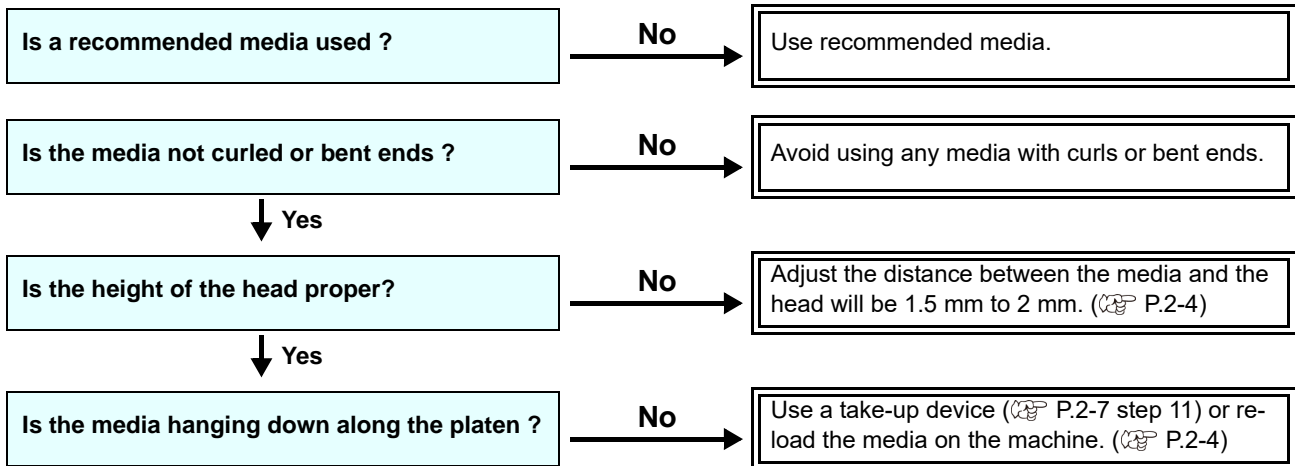

● If the media gets clogged, perform the work below:

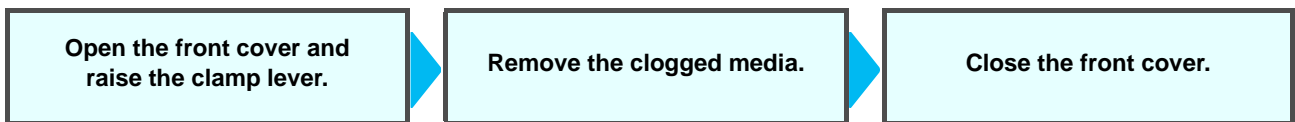

Image quality is poor

This section describes the corrective actions to be taken in case the image quality is not satisfactory.

Take remedy for particular problems with image quality. If the remedy does not work, contact your dealer or an office of MIMAKI.

Phenomenon	Measures
White lines / blur / dark stripes (in the direction of travel of the heads)	(1) Execute the head cleaning. (☞ P.2-23) (2) Perform maintenance of the inside of the station. (☞ P.4-7) (3) Execute the [MEDIA COMP.] function. (☞ P.4-12) (4) If any pieces of paper or dust is attached on the path of the heads such as media press, remove it.
Characters are double- or triple-printed in the media feed direction	(1) Execute the [MEDIA COMP.] function. (☞ P.2-24)
Disagreement in print positions between outward trip and homeward trip	(1) Execute the [DROP POSITION] function. (☞ P.2-25)
Ink drops falling on media during printing	(1) Execute the wiper cleaning. (☞ P.4-7) (2) Execute the ink cap cleaning. (☞ P.4-7) (3) Clean around the head. (☞ P.4-12) (4) Execute the head cleaning [Normal]. (☞ P.2-23) (5) Set a shorter interval of Interval Wiping operation. (☞ P.3-11)

Nozzle is clogged

When nozzle missing is not dissolved even after the head cleaning referring to P.2-23, make sure the following operations.

- Maintenance the sub tank by the operations of P.5-5
- Carry out air ventilation by the operations of P.5-5
- Wash the head nozzle by the operations of P.4-13.
- Recovery the nozzle by the operations of P.4-14.

Ink tank warning appears

If an ink tank trouble is detected, a warning message appears.

None of printing, cleaning and all the other operations that use ink is available. If an abnormality occurs, perform the following procedures:

- Check the ink amount in the ink tank and if the ink amount is not enough, add ink.

Important!

- Once ink tank trouble is displayed, do not leave the ink bottle without replacing it for a long time; otherwise, the machine will lose the nozzle missing prevention function. If nozzles are clogged, the machine must be repaired by MIMAKI's service engineer.

When the ink leakage occurs

In case of ink leakage, please turn off the main power, unplug the power cable and contact your local distributor, our sales office or our call center.

Displaying the description of ink bottle trouble

The contents of ink bottle error are confirmable by the following operations.

- 1 Press the **ENTER** key in Local.

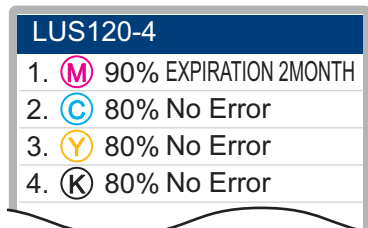

If an error related to the Sub Tank occurs (Error 618 to 61b)

The Error 618 to 61b are related to the sub tank. Execute following procedures when an error about sub tank occurs, or when the nozzle is not unclogged after cleaning.

- 1 Press the **FUNC1** (MENU) in Local.

- 2 Press **▲▼** to select "Maintenance", and press the **ENTER** key.

• Maintenance MENU appears.

- 3 Press **▲▼** to select "Sub Tank", and press the **ENTER** key.

- 4 Press **▲▼** to select the sub tank for maintenance, and then press **FUNC2** (✓).

• Maintenance is performed only on the sub tanks marked with "✓" (those selected by pressing [FUNC2]).

- Check the test printing results (P.2-23), and then select the sub tanks for maintenance.
- The test printing results and the corresponding sub tank numbers are shown below.

Important!

- If you perform this setting while a sub tank-related error occurs, the sub tank causing the error is automatically selected. In this case, you cannot select sub tanks by pressing [▲] and [▼].

4-colors ink

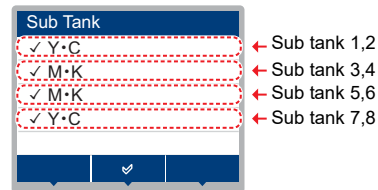

- Test printing results and the corresponding sub tank numbers

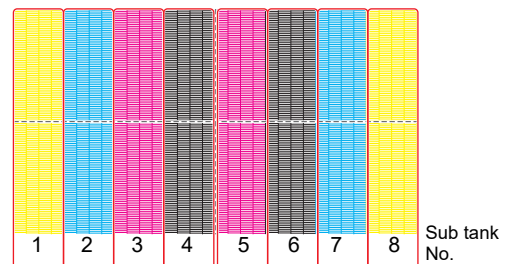

6-colors + White ink

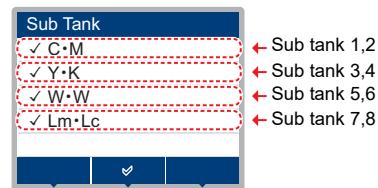

- Test printing results and the corresponding sub tank numbers

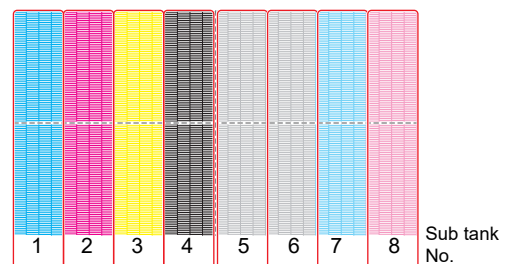

- 5 Press the **ENTER** key.

• The maintenance action selection screen appears.

- 6 Press the **ENTER** key.

• Discharge the ink in the sub tank, and charge ink into the tank.
• When the charging into the sub tank is completed, the air purging selection screen appears.

- 7 Press **▲▼** to select action, and press the **ENTER** key.

• Select "Execute" to move to the air purge menu.
• Select "Completed" to perform head cleaning.

If nozzle missing due to color mixture of ink or aeration

If nozzle missing occurs due to color mixture of ink in the head or aeration, push ink or air in the head out from the port.

Important!

- Ink may drop from the nozzle during air ventilation. An operator should not leave this machine during air ventilation.

1 Press the **[FUNC1]** (MENU) in Local.

2 Press **[▲]****[▼]** to select “Maintenance”, and press the **[ENTER]** key.

- Maintenance MENU appears.

3 Press **[▲]****[▼]** to select “Air PG”, and press the **[ENTER]** key.

- The station moves downward to the empty absorption position.
- When it lowers to the empty absorption position, “Open Cover” is displayed on the screen.

4 Open the right lower maintenance cover.

5 Open the maintenance cover before the carriage.

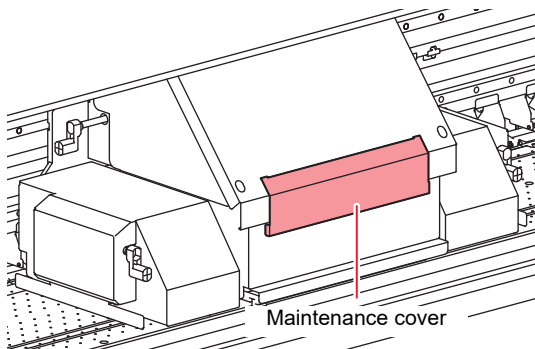

Important!

- After the work has been completed, attach the removed cover as soon as possible. If you leave it for a long time, UV light may affect ink.

6 Cover the rail part before the station with a waste cloth etc.

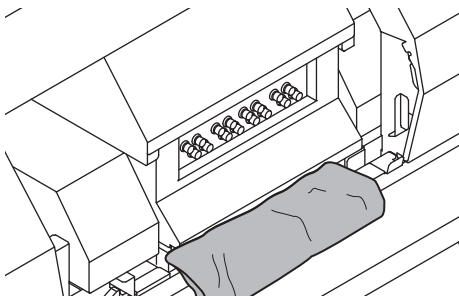

Important!

- Be sure to cover the rail part before performing the work. If ink drops on the rail part, ink will be hardened and it may cause the operation defect.

7 Press the **[ENTER]** key.

8 Press **[▲]****[▼]** to select the ink channel for maintenance, and then press **[FUNC2]** (✓).

- Maintenance is performed only on the ink channels marked with “✓” (those selected by pressing [FUNC2]).
- Check the test printing results (P.2-23), and then select the ink channels for maintenance.
- The test printing results and the corresponding ink channels are shown below.

4-colors ink

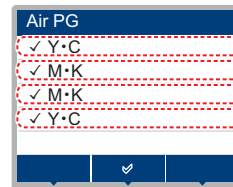

- ← Ink channel 1
- ← Ink channel 2
- ← Ink channel 3
- ← Ink channel 4

- Test printing results and the corresponding Ink channels

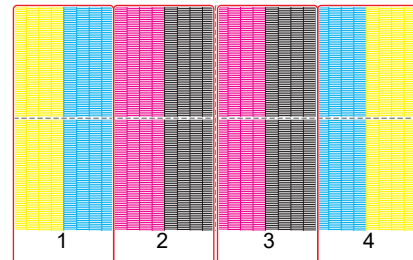

Ink channel

- Ink ports and the corresponding ink channels

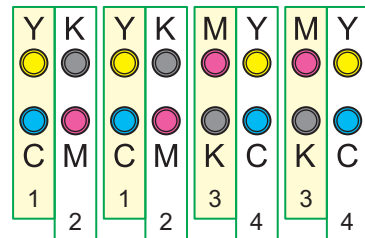

Ink channel

6-colors + White ink

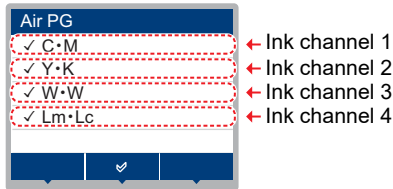

- Test printing results and the corresponding Ink channels

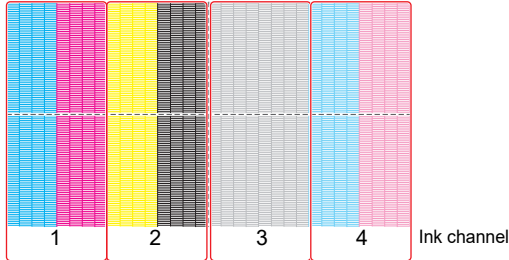

- Ink ports and the corresponding ink channels

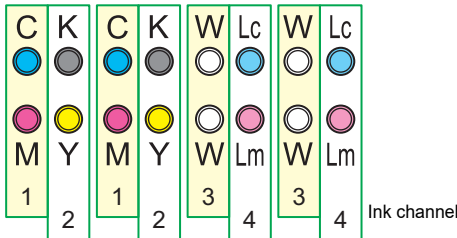

9 Press the **ENTER** key.

10 Press the **ENTER** key on the start confirmation screen.

- Micropositive pressure starts.

4-colors

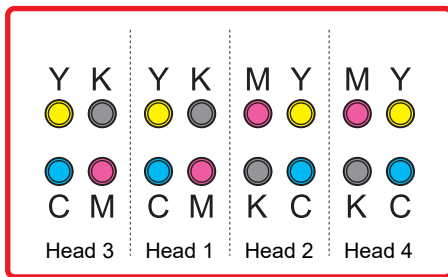

6-colors +white

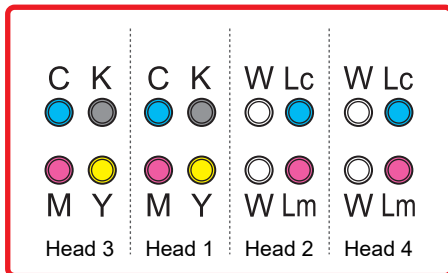

11 Remove the cap of the ink port and set the air purge jig.

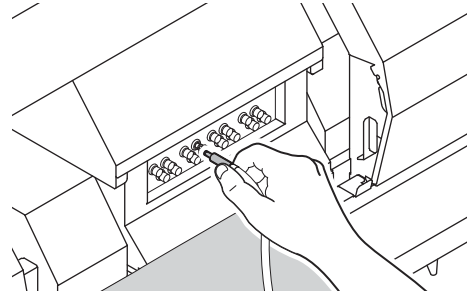

Important!

- When the valve is hard to open, use the attached longnose pliers and open.
- Do not remove the caps of the ink ports corresponding to unselected channels; otherwise, air may be gotten inside the head, which can lead to nozzle missing.

12 Discharge ink or purge air from inkport.

- Press [FUNC2](✓).
 - Discharging of ink and air (positive pressure status) starts.
 - In the positive pressure status, [PURGE] appears on the display.
- When the discharging is completed, press [FUNC2](✓) to reduce the momentum of discharging (micropositive pressure status).
 - Every time [FUNC2](✓) is pressed, the status switches between micropositive pressure and positive pressure.
 - In the micropositive pressure status, [----] is displayed on the display.
 - After 30 seconds remaining in positive pressure state, it automatically states micropositive pressure.

13 Make sure the display of “Please wait” is off from the display.

14 Remove the jig from the ink port, and cap the ink port.

- It is recommended to remove the jig in the micropositive pressure status to prevent ink from spouting.
- The machine supplies ink into the sub tank containing less ink. Wait for a while until the display changes.
- To continue work, follow the steps 10 and 11.

15 Press **▲▼** to select “RETRY” or “END”.

- To finish work, select “END”, press the A key, and proceed to step 16.
- To continue work, select “RETRY”, press the [ENTER] key, and follow the steps 8 through 14.

- 16** Wipe ink adhering to the ink port with a waste cloth and remove the waste cloth covering the rail.

Important!

- Wipe ink adhering to the ink port. Otherwise, it may cause the operation defect.

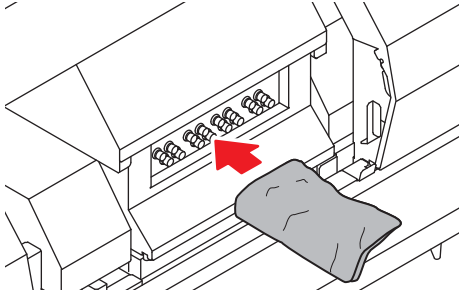

- 17** Close the maintenance cover before the carriage and the right lower maintenance cover of this machine. Then, press the **ENTER** key.

- Cleaning starts automatically. Wait for a while until cleaning has been completed.

- 18** Press **END/POWER** the key several times to end the setting.

When media heaves up at feeding

We call the status of heaving media at feeding “cockling”.
When media cockling occurs, check the following items:

Note/ checking items	Measures
Checking media set status	(1) Check that the media is set straight and reset it.
Adjusting heater temperature	(1) Upper pre-heaters' temperatures.
Media feeding	(1) For roll media, feed the media by about tens of centimeters to one meter. (2) For leaf media, press [▲] [▼] and perform feed/ back feed.
Do not leave the media in the heater warming status	(1) Do not start printing with the media cockled because it may cause media jam.
Heighten the head	(1) For the thick media, make the head gap higher before printing.

Warning / Error Messages

If some trouble occurs, the buzzer sounds and the display shows a corresponding error message. Take an appropriate remedy for the displayed error.

Warning messages

Errors when performing operations

Message	Cause	Solution
ERROR 901 INVALID OPERATION	Operation error	<ul style="list-style-type: none"> Return to the LOCAL screen, check the error status, and take appropriate actions.
ERROR 902 DATA REMAIN	There remains received data that has not yet been printed.	<ul style="list-style-type: none"> Execute the data clear function. (☞ P.2-26)
ERROR 90f PRINT AREA SHORT	The media is not wide or long enough for printing.	<ul style="list-style-type: none"> If the media width is decreased because the origin is moved, shift the origin to the right to increase the effective media width. Replace the media with one having enough width or length.

Errors when ink charging is performed

Message	Cause	Solution
INK IC Expiration CHARGE ANYWAY? NO < > YES	The expiration date for the inserted IC chip has passed.	<ul style="list-style-type: none"> Replace the IC chip with the IC chip of a new ink bottle. Select [YES] to continue to use the ink.
IC Expiration:1MONTH CHARGE ANYWAY? NO < > YES	The expiration date of the inserted IC chip has passed (one month has passed after the specified expiration date).	
IC Expiration:2MONTH CANNOT CHARGE	The expiration date of the inserted IC chip has passed (two months have passed after the specified expiration date).	<ul style="list-style-type: none"> Please insert the IC chip of the ink bottle within the expiration date. If an error occurs before the expiration date, please check the time of the machine.
WRONG INK IC CANNOT CHARGE	The IC chip cannot be read normally.	<ul style="list-style-type: none"> REMOVE the IC chip, and insert again. If displaying again, contact a distributor in your district, our office, or our call center to call for service.
INK IC ALREADY USED CANNOT CHARGE	An IC chip that has already been charged was inserted.	<ul style="list-style-type: none"> Install the new IC chip.
INK TYPE CANNOT CHARGE	The type of ink on the inserted IC chip is different from the ink in the bottle.	<ul style="list-style-type: none"> check WHETHER the IC chip is supplied with the ink bottle. Make sure the ink type of ink bottle.
INK COLOR CANNOT CHARGE	The color of ink on the inserted IC chip is different from the ink in the bottle.	<ul style="list-style-type: none"> check WHETHER the IC chip is supplied with the ink bottle. Make sure the ink color of ink bottle.
Expiration CHARGE ANYWAY? NO < > YES	The expiration date of the ink currently in use has passed.	<ul style="list-style-type: none"> Select replace operation in the ink tank menu to replace of ink in the tank, and then charge ink again. Select [YES] to continue to use the ink.
Expiration:1MONTH CHARGE ANYWAY? NO < > YES	The expiration date of the ink currently in use has passed. (one month has passed after the specified expiration date).	
Expiration:2MONTH CANNOT CHARGE	The expiration date of the ink currently in use has passed. (one month has passed after the specified expiration date).	

Message	Cause	Solution
INK LEVEL REMAINS CANNOT CHARGE	The charged ink level is nearly full, so ink cannot be charged.	<ul style="list-style-type: none"> Check if the IC chip provided with the ink bottle is inserted.
INK LEVEL REMAINS CHARGE ANYWAY?	Ink charging is attempted when the charged ink amount remains more than a certain level.	<ul style="list-style-type: none"> Check if the IC chip provided with the ink bottle is inserted. Select [YES] to perform ink charging.

Message displayed in LOCAL

Message	Cause	Solution
INK ERROR	An ink error occurred.	<ul style="list-style-type: none"> Check the ink bottle for the supply path corresponding to the indicated color.
InkOverflow : MCKYK	It was detected that the overflow of subtank.	<ul style="list-style-type: none"> Perform "SUBTANK" of the Maintenance menu. (P.5-4) If displaying again, contact your local distributor, our sales office, or service center.
TANKlevelH : MCKYK	The sub tank sensor High does not change though a certain amount of ink has been consumed.	
TANKlevelL : MCKYK	The sub tank sensor Low does not change though a certain amount of ink has been consumed.	
SUPPLY INK : MCKYK	Ink could not be supplied to the sub tank.	<ul style="list-style-type: none"> Perform "SUBTANK" of the Maintenance menu. (P.5-4) Also check the remaining amount of ink in the ink bottle. (P.1-11) If displaying again, contact your local distributor, our sales office, or service center.
SubtankSens : MCKYK	Detected an abnormality of the liquid level sensor of the sub tank.	<ul style="list-style-type: none"> Turn the main power off once and turn it back on after some time. (P.2-3) If displaying again, contact your local distributor, our sales office, or service center.
REPLACE INKTANK : MCKYKW_ _ _	Time to replace the ink tank of the displayed color (A certain period has passed since the start of use of the ink tank.)	<ul style="list-style-type: none"> Perform "Replace Ink Tank" (P.4-22) of the Maintenance menu. The ink charge information is also reset. After replacing the ink tank, charge the new IC chip and refill ink. (P.1-11)
INKTNK SENS : MCKYKW_ _ _	Detected an abnormality of the ink tank sensor.	<ul style="list-style-type: none"> Make sure the ink supply unit is connected to the machine. Check if any weight or load is taken on the ink tank. Implement the "tank calibration" of the Maintenance menu, and perform the correction of the balance. (P.4-23) If the error is still displayed after this, contact a distributor in your district, our office, or our call center to call for service.
Calibration MCKYKW_ _ _	Not performed the tank calibration.	<ul style="list-style-type: none"> Implement the "tank calibration" of the Maintenance menu. (P.4-23)
UV LAMP TEMP. HIGH	The UV unit temperature is high.	<ul style="list-style-type: none"> Wait for a while until the temperature lowers and the message disappears. If displaying again, contact your local distributor, our sales office, or service center.
Replace UV LAMP	Time to replace the UV lamp.	<ul style="list-style-type: none"> Adjust the amount of light in the "UV mode" in the setting menu. If a UV curing is insufficient, contact a distributor in your district, our office, or our call center to call for service.
REFILL WATER	Water in the cooling water tank is insufficient.	<ul style="list-style-type: none"> Replenish the antifreeze mixed water. (P.4-27)

Message	Cause	Solution
WATER LACK	It has passed more than seven days after water in the cooling water tank become low.	<ul style="list-style-type: none"> Replenish the antifreeze mixed water. (☞ P.4-27) While displaying this warning, you will not be able to print.
Take-UP CoverOPEN	It was detected that the media take-up device's cover was open.	<ul style="list-style-type: none"> Close the take-up device's cover.
Take-UP WRONG	An abnormality occurred in the take-up status of the media take-up machine.	<ul style="list-style-type: none"> Check if the media setting is set to ROLL when the take-up device is not used. Check if the taking-up direction switch and the taking-up manual switch are set correctly. (☞ P.2-6,P.2-7) Check that the media is set on the media take-up machine correctly. Check if the media take-up paper core is running without load. Turn ON and OFF the manual switch, and raise the tension bar to a correct position. Feed the media in the jog operation in the direction reverse to that used at the time when the error occurred.
Take-UP LimitDETECT	The control limit sensor of the media take-up machine was detected.	<ul style="list-style-type: none"> Check if the media can be fed correctly in the jog operation. Lower the position of the tension bar at the take-up side. If displaying again, contact your local distributor, our sales office, or service center.
TAKE-UP ENC WRONG	An abnormality occurred in the take-up encoder.	<ul style="list-style-type: none"> Turn the main power off once and turn it back on after some time. (☞ P.2-3)
Take-UP Connect	The take-up unit is not correctly connected.	<ul style="list-style-type: none"> If displaying again, contact your local distributor, our sales office, or service center.
Take-UP Fuse Err	The take-up fuse is blown.	
TAKE-UP TENSION-BAR	The media set check at the start of printing detected an abnormality of the take-up tension bar.	<ul style="list-style-type: none"> Check the media set condition and remove any cause of the problem. Check that the taking-up direction switch is set correctly. (☞ P.2-6)
Take-UP Voltage	An abnormality occurred in the take-up unit voltage.	<ul style="list-style-type: none"> Turn the main power off once and turn it back on after some time. (☞ P.2-3) If displaying again, contact your local distributor, our sales office, or service center.
Feeding CoverOPEN	It was detected that the media feeding device's cover was open.	<ul style="list-style-type: none"> Check the cover of the feeding unit. Even if you close the cover, If displaying again, contact your local distributor, our sales office, or service center.
Feeding WRONG	An abnormality occurred in the feeding status of the media feeding machine.	<ul style="list-style-type: none"> Check if the media setting is set to ROLL when the feeding device is not used. Check if the taking-up direction switch and the feeding manual switch are set correctly. Check that the media is set on the media feeding machine correctly. Check if the media feeding paper core is running without load. Turn ON and OFF the manual switch, and raise the tension bar to a correct position. Feed the media in the jog operation in the direction reverse to that used at the time when the error occurred.
Feeding LimitDETECT	The control limit sensor of the media feeding machine was detected.	<ul style="list-style-type: none"> Check if the media can be fed correctly in the jog operation. Lower the position of the tension bar at the feeding side. If displaying again, contact your local distributor, our sales office, or service center.

Message	Cause	Solution
FEEDING ENC WRONG	An abnormality occurred in the feeding encoder.	<ul style="list-style-type: none"> • Turn the main power off once and turn it back on after some time. (☞ P.2-3) • If displaying again, contact your local distributor, our sales office, or service center.
Feeding Connect	The feeding unit is not correctly connected.	
Feeding Fuse Err	The feeding fuse is blown.	
FEEDING TENSION-BAR	The media set check at the start of printing detected an abnormality of the feeding tension bar.	<ul style="list-style-type: none"> • Check the media set condition and remove any cause of the problem. • Check that the feeding direction switch is set correctly. (☞ P.2-6)
Feeding Voltage	An abnormality occurred in the feeding unit voltage.	<ul style="list-style-type: none"> • Turn the main power off once and turn it back on after some time. (☞ P.2-3) • If displaying again, contact your local distributor, our sales office, or service center.
NCU SENSOR LEVEL LOW	The NCU sensor sensitivity is falling.	<ul style="list-style-type: none"> • Replacement of the NCU is recommended. • Contact your local distributor, our sales office, or service center.
Nozzle Missing Print Stopped	Because the nozzle check found nozzles missing, printing was stopped.	<ul style="list-style-type: none"> • Check the nozzle condition. If there is plenty of deflection and/or nozzle missing, clean and restore the affected nozzles. (☞ P.2-23) • If displaying again, contact your local distributor, our sales office, or service center.
NCU FLUSH POS Nozzle check OFF	Because an NCU-related error occurred during nozzle check, printing was stopped and the nozzle check function was turned OFF.	
NCU CENTER POS Nozzle check OFF		
NCU SN ADJST Nozzle check OFF		
NCU NZK CHK (HW) Nozzle check OFF		
NCU NZK CHK (MARK) Nozzle check OFF		
NCU CONNECT		The NCU unit is not connected. The nozzle check function cannot be used.
REPLACE NCU	The NCU sensor sensitivity is too low to correctly judge nozzle missing. The nozzle check function cannot be used.	<ul style="list-style-type: none"> • NCU replacement is necessary. Contact our service desk or your local distributor to call for service.
REPLACE NCU INK PAD	The NCU ink pad is full.	<ul style="list-style-type: none"> • It is necessary to replace the NCU ink pad. Contact your local distributor, our sales office, or service center.
NCU ERROR Nozzle check OFF	Because an NCU-related error occurred during nozzle check, printing was stopped and the nozzle check function was turned OFF.	<ul style="list-style-type: none"> • Check the nozzle condition. If there is plenty of deflection and/or nozzle missing, clean and restore the affected nozzles. (☞ P.2-23) • If displaying again, contact your local distributor, our sales office, or service center.
REPLACE WIPER	Time to replace the wiper on the capping station (The number of times of wiping has reached a specified value.)	<ul style="list-style-type: none"> • Perform [Replace Wiper] in [Station], and replace the wiper. (☞ P.4-20)
DATA REMAIN	Data was received.	<ul style="list-style-type: none"> • Execute the data clear. (☞ P.2-26) Restart if the error message remains after the execution of the data clear.
MACHINE TEMP./H ****°C	The machine is hot.	<ul style="list-style-type: none"> • Use cooling equipment to lower the room temperature to a specified range. • Wait until the machine cools down. • If displaying again, contact your local distributor, our sales office, or service center.
MACHINE TEMP./L ****°C	The machine is cold.	<ul style="list-style-type: none"> • Use a heating system to raise the room temperature to a specified range. • Wait until the machine warms up. • If displaying again displaying again, contact your local distributor, our sales office, or service center.

Message	Cause	Solution
Please check the hight of Jam Sensor	The height of the jam sensor is not correct.	<ul style="list-style-type: none"> Match the height of the jam sensor to the appropriate height.
MEDIA JAM	Detected media jam.	<ul style="list-style-type: none"> Eliminate the media jam and press the [ENTER] key. If the problem can not be eliminated, contact a distributor in your district, our office, or our call center to call for service.
Cover Open	Detected cover open.	<ul style="list-style-type: none"> Check the cover (front cover, right maintenance cover, left maintenance cover), close the cover if open, and press the [ENTER] key. If the problem can not be eliminated, contact a distributor in your district, our office, or our call center to call for service.

Error messages

When an error message is displayed, eliminate the error according to the chart below.
If displaying again, contact your dealer or an office of MIMAKI to call for service.

Message	Cause	Solution
ERROR 04 PARAM ROM	The PCB is defective.	<ul style="list-style-type: none"> • Turn the main power off once and turn it back on after some time. • If displaying again, contact your local distributor to call for service.
ERROR 108 HD CONNECT [1234]	Abnormal connection of the print head	
ERROR 108 HD THERMIS [1234]	Abnormal temperature of the print head	
ERROR 108 HD MEM EMP [1234]	The print head has been broken.	
ERROR 108 HD TYPE [1234]		
ERROR 128 HDC FIFO OVER	Control circuit board is defective.	
ERROR 128 HDC FIFO UNDER		
ERROR 128 BATTERY EXCHANGE	The battery life end of the internal clock is detected.	<ul style="list-style-type: none"> • Contact your local distributor to call for service.
ERROR 12a HDC SPEED [12]	Ink discharge control error	<ul style="list-style-type: none"> • Turn the main power off once and turn it back on after some time. • If displaying again, contact your local distributor to call for service.
ERROR 12b HEAD ROM WR	Head control error	
ERROR 12e HeadFaild /HDC[**]	The print head has been broken.	
ERROR 130 HD DATA SEQ	Control circuit board is defective.	
ERROR 148 E-LOG SEQ		
ERROR 151 Main PCB V1R2	An error occurred in the main power.	
ERROR 152 Main PCB V2R5		
ERROR 153 Main PCB V3R3		
ERROR 154 Main PCB V05		
ERROR 155 Main PCB V36-1		
ERROR 157 Main PCB VTT		
ERROR 158 Main PCB V36-2		
ERROR 15f HEAD DRIVE HOT	The temperature abnormality of control circuit board has been detected.	
ERROR 16e Main PCB V3R3B	An error occurred in the main power.	
ERROR 171 NEW HEAD CONNECT	Connection of a new head was recognized.	

Message	Cause	Solution	
ERROR 186 HDC OVERFLOW [12]	Ink discharge control error	<ul style="list-style-type: none"> • Turn the main power off once and turn it back on after some time. • If displaying again, contact your local distributor to call for service. 	
ERROR 186 HDC UNDERFLOW [12]			
ERROR 187 HDC SLEW RATE [12]	Ink discharge control error		
ERROR 188 HDC MEMORY [12]			
ERROR 18a Main PCB V_CORE	An error occurred in the main power.		
ERROR 18b Main PCB V1R5B			
ERROR 18c Main PCB V12			
ERROR 18e FLS NOT COMP [12]	Ink discharge control error		
ERROR 18f OFFSET START [12]			
ERROR 18f OFFSET END [12]			
ERROR 19d HDC V36 [12]	Abnormal ink discharge voltage was detected.		
ERROR 19f LED CONNCT ERR**	UV-LED board unconnected		
ERROR 201 COMMAND	Abnormal communication between PC and printer	<ul style="list-style-type: none"> • Check the USB cable connection. Use a USB cable conforming to the standard. 	
ERROR 202 PARAMETER			
ERROR 203 Ment Command			
ERROR 206 PRINTING MODE		<ul style="list-style-type: none"> • Check the USB cable connection. Use a USB cable conforming to the standard. • Check output conditions. 	
ERROR 304 USB INIT ERR	USB device error.	<ul style="list-style-type: none"> • Turn the main power off once and turn it back on after some time. • If displaying again, contact your local distributor to call for service. 	
ERROR 305 USB TIME OUT			
ERROR 306 USB GET DESC			
ERROR 401 MOTOR X	An excessive load was applied to the X motor.		
ERROR 402 MOTOR Y	An excessive load was applied to the Y motor.		
ERROR 403 X CURRENT	An error due to an excessive current of the X motor was detected.		
ERROR 404 Y CURRENT	An error due to an excessive current of the Y motor was detected.		
ERROR 41b ** NO MEDIA **	With no media loaded properly, the clamp moved down.		<ul style="list-style-type: none"> • Load media so that the media comes within the range of the media sensor.
ERROR 423 TAKE-UP TENSION-BAR	The media set check detected abnormality of the take-up tension bar at the start of printing.		<ul style="list-style-type: none"> • Check the media set condition, and remove any problem.
ERROR 424 FEEDING TENSION-BAR	The media set check detected abnormality of the feeding tension bar at the start of printing.		

Message	Cause	Solution
ERROR 425 Take-UP WRONG	An error occurred in the take-up status of the take-up unit.	<ul style="list-style-type: none"> • Check if the media setting is set to ROLL when the take-up device is not used. • Check if the taking-up direction switch and the taking-up manual switch are set correctly. • Check that the media can be taken up to the take-up unit. • Check if the media take-up paper core is running without load. • Turn ON and OFF the manual switch, and raise the tension bar to a correct position. • Feed the media in the jog operation in the direction reverse to that used at the time when the error occurred.
ERROR 426 Feeding WRONG	An error occurred in the take-up status of the feeding unit.	<ul style="list-style-type: none"> • Check if the media setting is set to ROLL when the feeding device is not used. • Check if the taking-up direction switch and the feeding manual switch are set correctly. • Check that the media can be taken up to the feeding unit. • Check if the media feeding paper core is running without load. • Turn ON and OFF the manual switch, and raise the tension bar to a correct position. • Feed the media in the jog operation in the direction reverse to that used at the time when the error occurred.
ERROR 427 Take-UP CoverOPEN	It was detected that the media take-up device's cover was open.	<ul style="list-style-type: none"> • Close the take-up device's cover.
ERROR 428 Feeding CoverOPEN	It was detected that the media feeding device's cover was open.	<ul style="list-style-type: none"> • Close the feeding device's cover.
ERROR 429 Take-UP LimitDETECT	The take-up limit was detected.	<ul style="list-style-type: none"> • Check if the media can be fed correctly in the jog operation. • Lower the position of the tension bar on the take-up side by using the manual switch.
ERROR 42a Feeding LimitDETECT	The feeding limit was detected.	<ul style="list-style-type: none"> • Check if the media can be fed correctly in the jog operation. • Lower the position of the tension bar on the feeding side by using the manual switch.
ERROR 432 Take-UP Connect	Take-up device connection destination error	<ul style="list-style-type: none"> • Turn the main power off once and turn it back on after some time. • If displaying again, contact your local distributor to call for service.
ERROR 433 Feeding Connect	Feeding device connection destination error	
ERROR 436 Take-UP Fuse Err	Take-up fuse blown	
ERROR 437 Feeding Fuse Err	Feeding fuse blown	
ERROR 442 Take-UP Voltage	An abnormality occurred in the take-up unit voltage.	
ERROR 443 Feeding Voltage	An abnormality occurred in the feeding unit voltage.	
ERROR 44d STATION POS ERROR	Abnormal station position	
ERROR 44e UV UNIT FAN ERROR	The UV unit fan does not operate.	
ERROR 46b TAKE-UP ENC WRONG	An error occurred in the take-up device.	

Message	Cause	Solution
ERROR 46c FEEDING ENC WRONG	An error occurred in the feeding device.	<ul style="list-style-type: none"> Turn the main power off once and turn it back on after some time.
ERROR 50a Y ORIGIN	Y-origin could not be detected.	<ul style="list-style-type: none"> If displaying again, contact your local distributor to call for service.
ERROR 50c MEDIA WIDTH SENSOR	The media width has not been detected correctly.	<ul style="list-style-type: none"> Check the media set position. Clean the media sensor. (☞ P.4-3)
ERROR 50f L-SCALE BLACK	Abnormal linear scale.	<ul style="list-style-type: none"> Turn the main power off once and turn it back on after some time. If displaying again, contact your local distributor to call for service.
ERROR 516 MEDIA SET POSITION R	The media is set outside the proper area.	<ul style="list-style-type: none"> Check the media set position.
ERROR 516 MEDIA SET POSITION L		
ERROR 531 INKTNK SENS : MCYKW_ _ _	Detected an abnormality of the ink tank sensor.	<ul style="list-style-type: none"> Make sure the ink supply unit is connected to the machine. Check if any weight or load is taken on the ink tank. Implement the "Tank Calibration" of the Maintenance menu, and perform the correction of the balance. If displaying again, contact a distributor in your district, our office, or our call center to call for service.
ERROR538 CHECK MEDIA SET POS.	The media is not set in the correct position.	<ul style="list-style-type: none"> Check the media set position.
ERROR 607 CAP CLEANING	Time to clean the cap	<ul style="list-style-type: none"> Clean the cap. (☞ P.4-7)
ERROR 617 SubtankSens : 1234	Detected an abnormality of the liquid level sensor of the sub tank.	<ul style="list-style-type: none"> Turn the main power off once and turn it back on after some time. If displaying again, contact your local distributor to call for service.
ERROR 618 TANKlevelH : 1234	The sub tank sensor High does not change though a certain amount of ink has been consumed.	<ul style="list-style-type: none"> Perform "SUBTANK" of the Maintenance menu. (☞ P.5-4) Even if you perform, it may be displayed, contact your local distributor to call for service.
ERROR 619 TANKlevelH : 1234	The sub tank sensor Low does not change though a certain amount of ink has been consumed.	
ERROR 61a InkOverflow : 1234	It was detected that the overflow of subtank.	
ERROR 61b SUPPLY INK : 1234	Ink could not be supplied to the subtank.	<ul style="list-style-type: none"> Perform "SUBTANK" of the Maintenance menu. (☞ P.5-4) Also make sure the ink remaining in the ink bottle. (☞ P.1-11) Even if you perform, it may be displayed, contact your local distributor to call for service.
ERROR 64b Nozzle Missing	The automatic nozzle check judged nozzles "No good".	<ul style="list-style-type: none"> Check the nozzle condition. If there is plenty of deflection and/or nozzle missing, clean and restore the affected nozzles. (☞ P.2-23) If displaying again, contact our service desk or your local distributor to call for service.
ERROR 64c NCU ERROR	Printing stopped because an error occurred during the nozzle check.	<ul style="list-style-type: none"> Turn the main power off once and turn it back on after some time. If displaying again, contact our service desk or your local distributor to call for service.
ERROR 650 NCU CONNECT	The NCU unit is not connected.?	
ERROR 651 REPLACE NCU	The NCU sensor sensitivity is too low to correctly judge nozzle missing. The nozzle check function cannot be used.	

Message	Cause	Solution
ERROR 652 NCU NZK CHK (HW)	The NCU cannot correctly recognize the ink discharge, because there are frequent nozzle missing and ink droplet misalignment.	<ul style="list-style-type: none"> • Check the nozzle condition. If there is plenty of deflection and/or nozzle missing, clean and restore the affected nozzles. (☞ P.2-23) • If displaying again, contact our service desk or your local distributor to call for service.
ERROR 653 NCU NZK CHK (MARK)		
ERROR 654 NCU CENTER POS		
ERROR 655 NCU FLUSH POS		
ERROR 656 NCU SN ADJST	Sensor sensitivity adjustment has failed.	
ERROR 657 REPLACE NCU INK PAD	The NCU ink pat is full.	<ul style="list-style-type: none"> • Contact our service desk or your local distributor to call for service.
ERROR 658 NCU SENSOR LV LOW	The NCU sensor sensitivity is falling.	<ul style="list-style-type: none"> • Replacement of the NCU is recommended. • Contact our service desk or your local distributor to call for service.
ERROR 702 THERMISTOR	The thermistor sensor of a heater is defective.	<ul style="list-style-type: none"> • Turn the main power off once and turn it back on after some time. • If displaying again, contact our service desk or your local distributor to call for service.
ERROR 703 ! PRE HEATER BRK	A pre-heater is disconnected.	
ERROR 705 WATER LACK	Water in the cooling water tank becomes less.	<ul style="list-style-type: none"> • Refill cooling water by referring to "Refill anti-freeze mixed water". (☞ P.4-27)
ERROR706 UV LAMP TEMP. HIGH	The LED lamp temperature is high.	<ul style="list-style-type: none"> • Stop printing, and wait until the temperature drops sufficiently.
ERROR 707 ! HD HEATER BREAK	A head heater is disconnected.	<ul style="list-style-type: none"> • Turn the main power off once and turn it back on after some time. • If displaying again, contact our service desk or your local distributor to call for service.
ERROR 710 HEATER TEMP ERROR	An abnormal temperature of the heater was detected. If the problem is not resolved after the occurrence of this error, the power to the machine is forced OFF.	
ERROR 714 INK HEATER COM ERR	There was a communication error in the ink heater board.	
ERROR 715 InkHeater Thr : 1234	The ink heater thermistor is defective.	
ERROR 716 InkHeater Tmp : 1234	The ink heater is too hot.	<ul style="list-style-type: none"> • Turn the main power off once and turn it back on after some time. <p>The following message is displayed at startup.</p> <div style="border: 1px solid black; padding: 5px; text-align: center;"> I NK HEATER CONTROL CANCEL < > START </div> <p>Press [▶] and start ink heater control.</p> <ul style="list-style-type: none"> • If displaying again, contact our service desk or your local distributor to call for service.
ERROR 717 InkHeater Brk : 1234	The ink heater is disconnected.	<ul style="list-style-type: none"> • Turn the main power off once and turn it back on after some time. • If displaying again, contact our service desk or your local distributor to call for service.
ERROR 718 InkHeaterPCB Thr : 1234	The thermistor on the ink heater relay board is defective.	
ERROR 719 InkHeaterPCB Fuse : 1234	The fuse on the ink heater relay board was blown.	
ERROR 71a UV-DRV Fuse : 0**0**	The fuse on the UV-DRV board was blown.	

SYSTEM HALT

Message	Solution
SYSTEM HALT (*) 000 :MESSAGE	<ul style="list-style-type: none">• Turn the main power off once and turn it back on after some time.• If displaying again, contact our service desk or your local distributor to call for service. ("000" is the error No.)

Chapter 6

Appendix



This chapter

contains the lists of the specifications and functions of this machine.

Specifications	6-2
Machine specifications	6-2
Ink specifications	6-3
Supply item list	6-4
Setting orders of ink tanks	6-5
Sheet for inquiry	6-6

Specifications

Machine specifications			
Item		4-colors	6-colors + White
Print head	Method	Drop-on-demand piezoelectric print heads	
	Specification	4 heads: 2-layered staggered arrangement in 2-line	
Printing mode (scan x feed)	Tarpaulins	300x600 / 300x900 / 600x900 (dpi)	
	PVC film	300x600 / 300x900 / 600x900 / 900x1200 (dpi)	300x600 / 300x900 / 600x900 / 900x1200 / 1200x1200 (dpi) ^{*1}
	Backlit tarpaulin	600x600 / 600x900 (dpi)	
	Film	_____	300x900 / 600x600 / 600x900 / 900x1200 / 1200x1200 (dpi) ^{*1}
Usable inks		LUS-120 ink (M,C,Y,K)	LUS-120 ink (M,C,Y,K,Lm,Lc,W)
Ink supply		4-colors: Supplying 3L x 4 bottles	6-colors + White: Supplying 3L x 7 bottles
Capacity of ink tank		3L-bottle x 1 for each color	
Media type		PVC film/ tarpaulins/ FF/ transparency film	
Max. printing width		3200mm (126.0 in) ^{*2 *3}	
Roll Media size	Maximum	3250mm (1524 mm each when twin rolls are set. 1620 mm when roll holders are used.) (128.0 in (60.0 in each when twin rolls are set. 63.8 in when roll holders are used.))	
	Minimum	210mm (8.3in)	
	Thickness	1 mm or less (0.04 in or less)	
	Roll outside diameter	When using take-up unit and feeding unit:Φ250 mm or less (Φ9.8 in or less)	
	Roll weight ^{*4}	When using feeding unit:100kg or less (220.4lb or less) When using roll holder:18kg or less (39.6lb or less)	
	Roll inside diameter	When using take-up unit and feeding unit:3 inches When using roll holder:2 or 3 inches	
	Printing surface	Regardless of inside and outside	
	Roll end treatment	The roll end is gently fixed to the core with weak-adhesive tape or weak glue for easy removal.	
Leaf media size	Maximum	3250mm (128.0in)	
	Minimum	210mm (8.3in)	
Margin	Leaf media	Left end and right end : 15 mm (Default) Front : 1400 mm Rear : 1300 mm (Left end and right end : 0.6 in (Default) Front : 55.1 in Rear : 51.2 in)	
	Roll media	Left end and right end : 15 mm (Default) Front : 1600 mm Rear : 1300 mm (Left end and right end : 0.6 in (Default) Front : 63.0 in Rear : 51.2 in)	
Distance accuracy	Reproducibility	Whichever the larger one of ± 1.5 mm or ± 0.3 % of the designated ^{*5 *6 *7} (Whichever the larger one of ± 0.1 in or ± 0.3 % of the designated ^{*5 *6 *7})	
Perpendicularity		± 0.5 mm / 1000 mm (± 0.01 in / 39.4 in)	
Media skew		5 mm or less / 10 m variable (0.2 mm or less / 32.8ft variable)	
Head height adjustment		1.7, 1.9, 2.6, 3.3 mm (0.06, 0.07, 0.10, 0.12 in)	
Media delivery		Take-up device supplied as a standard accessory (switching possible between face in and face out ^{*8}).	
Waste ink tank		Tank type (10 liter)	
Interface		USB 2.0 / Ethernet 1000BASE-T	
Command		MRL V	
Noise ^{*9}	during standby	58 dB or less (FAST-A, Front & Rear & Left & Right 1 m)	
	during continuous printing	65 dB or less	
	during discontinuous printing	70 dB or less	
Power		AC200 - 240 ± 10 % , 50/60Hz ± 1 Hz , 18A or less	
Power consumption		4.3 KW or less	

Item		4-colors	6-colors + White
Recommended Environment	Available temp.	20 °C to 30 °C (68°F to 86°F)	
	Humidity	35 to 65% Rh (No condensation)	
	Guaranteed temp.	20 °C to 25 °C (68°F to 77°F)	
	Temperature change	± 10 °C / h or less (± 50 °F / h or less)	
	Dust	0.15mg/m ³ (Equivalent to normal office level)	
	Highest operation height	2000 m (6561.7 ft)	
Weight	Printer main unit	850 kg (1873.9 lb)	
Outside dimensions	Printer main unit	5410 mm(W) x 995 mm(D) x 1440mm(H) (17.7 in(W) x 3.3 in(D) x 4.7in(H))	

*1. The maximum print width of 1200x1200dpi is up to 2700mm width.

*2. When print in the print mode 1200x1200dpi, the maximum print range will be "2700mm".

*3. When use twin roll and print in the print mode of 1200x1200dpi, it is possible to print until 2700mm from the print start position of the media that is set on the right-hand side.

*4. Without deflection of the roll when it is retained at both ends.

*5. The expansion and/or contraction of media is excluded.

*6. The initial meandering of the media which is just set is excluded.

*7. Only if all the following conditions are met:

The media is set in the center of the machine.

The Logical Seek is set to Quality.

When roll holders are used, printing is started on a roll having no deflection.

The take-up device is used.

One roll media is used (except for twin rolls).

*8. "Involved" for the media take-up direction is recommended.

*9. 65.1dB(A), Operating Condition: Full load Measuring Method: According to clause 1.7.4.2 of Machinery Directive 2006/42/EC

Ink specifications

Item		Specifications
Supply		1L Ink bottle
Color		Black ink Cyan ink Magenta ink Yellow ink Light cyan ink Light magenta ink White ink
Ink capacity		1 liter
Shelf life		The period is printed on the ink bottle. Within three months after opening the package even in the available period.
Storage temperature	Storage	5 to 30°C (41 to 86°F)
	Transportation	1 to 60°C (Storage at temperature of 60°C (140°F) is only permitted within 120 hours, and at temperature of 40°C (104°F) is permitted within a month.)



- Do not disassemble the ink bottle.
- Ink could freeze if kept in a cold place for an extended period.
- If the ink freezes, thaw it at room temperature (25°C) spending more than three hours before use. However, when you use the frozen ink, the printing quality becomes degraded due to altered ink. Store ink in the environment where ink may not freeze.

Supply item list

Product No.	Name
I-LUS12-K-BA	UV ink LUS-120 Black ink (1liter)
I-LUS12-C-BA	UV ink LUS-120 Cyan ink (1liter)
I-LUS12-M-BA	UV ink LUS-120 Magenta ink (1liter)
I-LUS12-Y-BA	UV ink LUS-120 Yellow ink (1liter)
I-LUS12-LC-BA	UV ink LUS-120 Light cyan ink (1liter)
I-LUS12-LM-BA	UV ink LUS-120 Light magenta ink (1liter)
I-LUS12-W-BA	UV ink LUS-120 White ink (1liter)
SPC-0766	H fan filter
SPC-0527	Clean stick for the surroundings of the head 50pcs
SPC-0568	Maintenance washing liquid
SPA-0193	Wiper kit
SPA-0263	Cap ink absorber kit
SPA-0266	3L ink bottle
SPA-0283	3L W ink tank Assy
SPC-0569	F-200/LF-200 CLEANING KIT
SPC-0769	Replacement tube for Air Purge Jig

Setting orders of ink tanks

The setting value and the setting orders of the ink tanks differ depending on the ink type you use.



- Refill the ink matching the label.
Do not refill the ink different in color from the label.

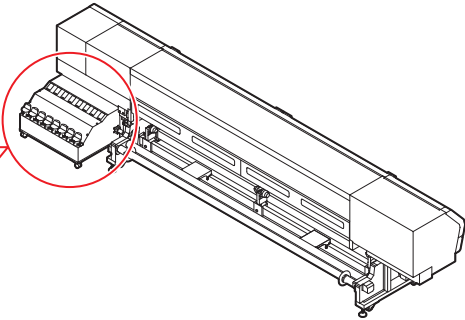
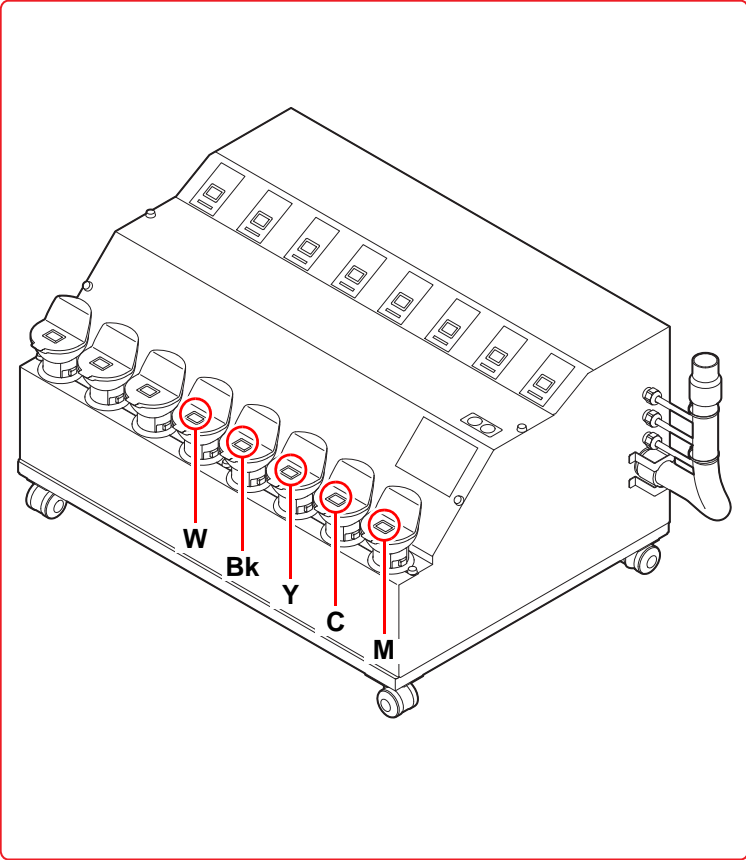
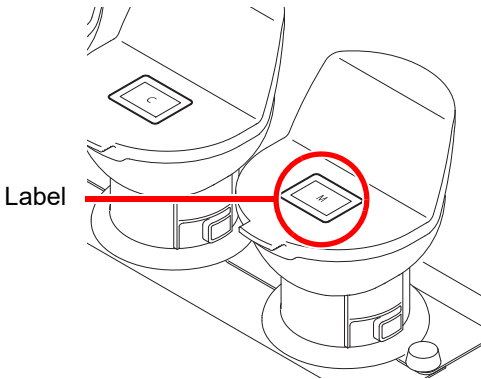

Sheet for inquiry

Use this sheet for troubles and abnormal functions of the machine.
Fill in the following necessary items, and fax the sheet to our sales office.

Company name	
Person in charge	
Telephone number	
machine model	
Operating OS	
Machine information *1	
Error message	
Contents of inquiry	

*1. Refer to "Confirming Machine information" of "About Information MENU" then fill in necessary information. (☎ P.3-25)

UJV55-320 Operation Manual

October, 2023

MIMAKI ENGINEERING CO.,LTD.

2182-3 Shigeno-otsu, Tomi-shi, Nagano 389-0512 JAPAN

D202964-16-26102023

