

CFX *Series*

Operation Manual

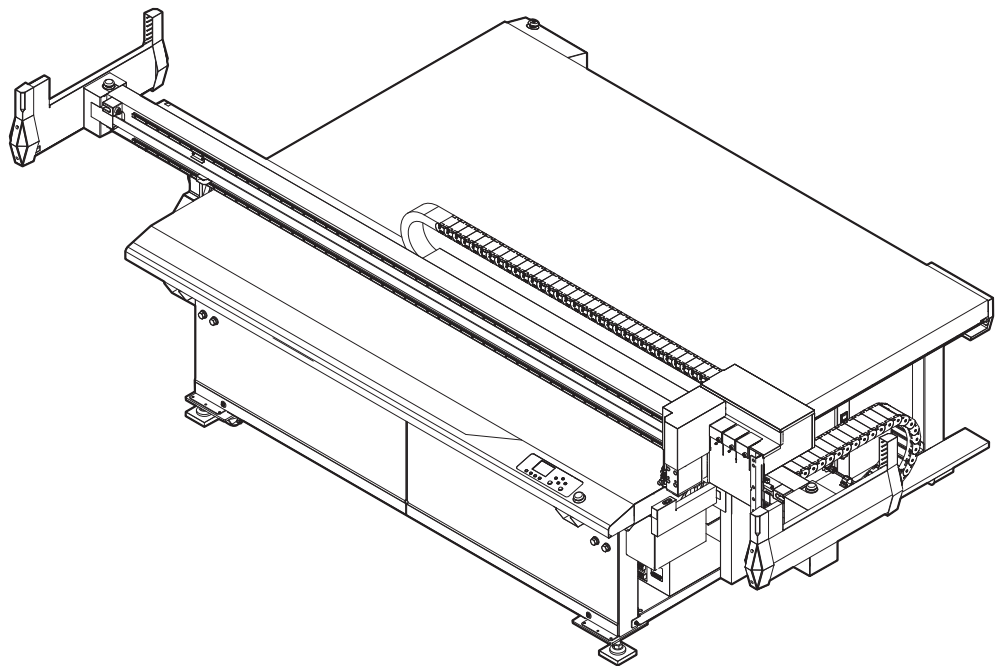

Download the latest version of the operation manual from our website.

MIMAKI ENGINEERING CO., LTD.

Table of Contents

CAUTION	vi
DISCLAIMERS	vi
TV and Radio Interference	vi
Usage Restrictions	vi
Introduction	ix
About This Operation Manual	ix
Accessories	ix
Safety Precautions	x
Symbols	x
Warning Labels	xiv

Chapter 1 Setup

Installation	1-2
Vacuum (Optional) Installation Position	1-5
Moving the Machine	1-5
Part Names and Functions	1-6
Main Unit	1-6
Head	1-7
Electrical Box Side	1-8
Vacuum Unit Electrical Box (Optional)	1-9
Head Side (When Equipped with Option/R10)	1-9
Operating Panel	1-10
Display	1-11
Cable Connections	1-14
Connecting the Power Cable	1-14
Connecting Interface Cables	1-14
Local/Remote Mode	1-15
Local Mode and Corresponding Display	1-15
Remote Mode and Corresponding Display	1-15
Emergency Stop	1-16
Using Emergency Stop	1-16
Resetting an Emergency Stop	1-16
Preparing the Cutting Panel	1-18
Attaching the Work Guides	1-18
Matching the Plotter Specifications	1-21
Setting Automatic Head Retraction	1-22
Setting the Vacuum	1-23
What is a vacuum unit?	1-23
Enabling/Disabling Auto Vacuum Off	1-23
Interlock between Remote Key and Vacuum	1-25
Setting the Camera Unit	1-26
Camera Unit Overview	1-26
Camera Settings	1-26
Adjusting Camera Image Quality	1-26

Chapter 2 Tools

Using a Combination of Units	2-2
Combining Stations and Units	2-2

Unit and Tool Combinations	2-2
Mounting Tools (Standard Unit)	2-4
Pen	2-4
Mounting a Pen Adapter	2-5
Swivel cutter (optional)	2-8
Mounting Tools (Tangential Unit)	2-10
Tangential Unit (TUT) Structure	2-10
Mounting the Tangential Unit	2-11
Mounting the Flat Blade Tool	2-14
Mounting a Reciprocating Cutter	2-17
Mounting a Creasing Tool	2-22
Mounting a V-cut Tool	2-26
Mounting the Work Holder	2-34

Chapter 3 Basic Operations

Basic Operation Flow	3-2
Turning the Power On	3-3
Moving the Head	3-4
Moving the Head with the [Move to View Pos.] Function	3-4
Moving the Head with the Jog Keys	3-5
Setting Underlay Thickness	3-6
Selecting whether or not underlay is used	3-6
Setting underlay thickness	3-7
Securing Works	3-9
Securing Works with Adhesive Tape	3-9
Securing Works with Vacuum	3-10
Setting Work Thickness	3-12
Cutting Edge Detection	3-14
Configuring Tool Settings	3-17
Selecting Tools	3-17
Changing Cutting Conditions	3-18
Setting items	3-19
Adjusting Tools	3-22
Adjusting Cutters	3-22
Circle Ø Correction	3-36
Test Cutting	3-38
Checking tool status	3-39
Checking Status Between Tools (Standard Unit, TUT)	3-42
Setting the Drawing Origin	3-45
Moving the Head to the Current Drawing Origin	3-46
Cutting or Drawing	3-47
Effective Cutting Area	3-47
Cutting or Drawing	3-47
Interrupting Processing	3-48
Resuming Processing	3-48
Stopping Processing (Data Clear)	3-49
Restarting After Safety Sensor Detection	3-50
Restart procedure after an emergency stop	3-50
Power OFF	3-51

Chapter 4 Helpful Tips

Function Setting List	4-2
Jog Mode Functions	4-4
2-point Axis Correction	4-5
Cutting Area Settings	4-6
Moving the Head to a Corner of the Cutting Area	4-7
Manual Cutting	4-8
Aligning the Pointer Position	4-9
Boot origin set	4-10
Assigning Pen Numbers	4-12
Cutting the Same Data Again (Copy)	4-13
Changing the Cutting Order	4-14
Setting Up Sorting	4-14
Setting the Cutter Stroke	4-15
Dummy Cutting with a Swivel Cutter (Only Standard Unit)	4-16
Setting the Close Time	4-17
Continuous Cutting	4-18
Continuous Cutting Function (Continue Mode)	4-18
Toggle Cutting (Toggle Mode)	4-18
Setup	4-20
Cutting	4-23
Restrictions in Continuous and Toggle Modes	4-27
Settings Initialized by Enabling/Disabling Continue Mode	4-27
Flat Follow-Up Function	4-28
About the flat follow-up function	4-28
Setting the flat follow-up function	4-29
Setting the felt mat flatness	4-30
Setting Felt Mat Thickness	4-31
Set by measuring flatness	4-31
Entering values manually	4-33
Other Useful Functions	4-34
Setting Cutting Quality	4-34
Setting the Speed of Head Movement	4-35
Setting an Offset for Adjusted Blade Pressure (Standard Unit)	4-36
Eliminating Pieces Left Uncut in Works (Standard Unit)	4-37
Setting Up a Double Roller Effect	4-39
Setting the Display Language	4-40
Setting the Display Unit	4-41
Setting the Key Buzzer	4-42
Setting Startup Mode	4-43
Setting Commands	4-44
Setting Computer Connection Conditions	4-46
Setting the Network	4-48
Copying Setting Values from Another User's Settings	4-50
Restoring Default Settings	4-51
Setting the Reciprocating Cutter Blade Position	4-52
Checking the Cutting Area in Advance	4-53
Switching Users	4-54
Checking Machine Information	4-55
Updating the Machine Firmware	4-56

Chapter 5 Register Mark Reading Functions

Precautions When Preparing Data with Register Marks	5-2
Register Mark Size	5-2
Supported Arrangements of Register Marks and Patterns	5-4
No-Drawing Areas Around Register Marks	5-6
Register Mark Color	5-9
Blurry or Smudged Register Marks	5-9
Setting Mark Detection Operation	5-10
Precautions on Mark Detection	5-10
Setting Mark Detection Operation	5-11
Mark Detection Camera Adjustment	5-13
Mark Detection Mode	5-14
Detecting the Mark Origin	5-15
Setting Mark Origin in Teaching Mode	5-16
Aligning the Register Mark Detection Position	5-17
Continuous Cutting with Register Marks	5-19
Linking Cutting and Printing (ID Cut)	5-20
Setting Up ID Cut	5-20
Backside Cutting Using Mark Chips	5-21
Surface Cutting Using Edge Detection	5-23
Backside Cutting Using Edge Detection	5-24

Chapter 6 Router unit R10

Mounting Tools (Router Unit)	6-2
Attaching the router unit R10	6-2
Adjusting the Router Unit R10	6-11
Creating Router Cutting Programs	6-14
Precautions When Using FineCut	6-14
Materials	6-15
Note about end mills	6-16
Recommended cutting conditions	6-16
End mill type	6-17
Mounting Conditions	6-18
End Mill and Collet Chuck Combinations and Positioning	6-19
Machining Procedure (Router Unit)	6-20
Machining Materials for the First Time or Materials Not Listed in Recommended Conditions	6-20
Machining Problems and Corrective Action	6-22
Basic Information on Router Machining	6-24
Check and clean inside the dust collection box.	6-26
Check inside the dust collection box	6-26

Chapter 7 Routine Maintenance

Routine Maintenance	7-2
Cutting Panel Surface	7-2
Operating Panel Surface	7-2

Covers	7-2
Cutter Blade Maintenance	7-2
Units	7-3
Cleaning the Vacuum Filter	7-5
Cleaning the Camera Unit	7-6
Cleaning the Photoelectric Sensors and LED Pointer	7-6
Cleaning the Mark Sensor/Y-Bar Rail	7-7
Dust-Collector Hose Maintenance (Only R10)	7-8
Cleaning with Auxiliary Air (Only R10)	7-9
Cleaning the Router Blade (End Mill) (Only R10)	7-9

Chapter 8 Troubleshooting

Troubleshooting Scenarios	8-2
Troubleshooting	8-3
Does not work when power is turned on	8-3
Sending data from software does not work	8-3
An error occurs when data is sent	8-3
The tool lifts up works (only standard unit)	8-4
Drawn lines are broken or faint	8-4
No reciprocating movement (only TUT)	8-4
Warning/Error Messages	8-5
Resolvable Errors	8-5
System Halt and Other Errors	8-13
Status Messages	8-13
Mark Origin Detection Errors	8-14
Error numbers displayed on spindle controller	8-15
Sample Cutting	8-16
Cutting Samples to Troubleshoot Issues	8-17

Chapter 9 Appendix

Specifications	9-2
Optional accessories	9-3
Options	9-3
Optional accessories	9-4
Accessories	9-8
OPT-C0248 Additional Table Unit for CFX	9-8
OPT-C0250 / OPT-C0271 Tangential Unit TUT-15	9-9
OPT-C0256 Flat Blade Tool - FBT	9-10
OPT-C0264 V-Cut Tool: 45° - V45	9-11
OPT-C0277 V-Cut Tool: 45° - V45 TYPE-S	9-11
OPT-C0265 V-Cut Tool: Angle Selection Type - VAS	9-12
OPT-C0265 V-Cut Tool: Angle Selection Type - VAS TYPE-S	9-12
OPT-C0249 5.5 kw / 6.3 kw Vacuum Unit Assy.	9-13
OPT-01035 7.5 kw / 8.6 kw Vacuum Unit 200 V Assy.	9-14
OPT-01036 7.5 kw / 8.6 kw Vacuum Unit 400 V Assy.	9-15
OPT-01037 toggle unit Assy.	9-16
OPT-C0252 Camera Unit - CAMERA	9-18
OPT-C0251 Router Unit: 1 kW - R10	9-19

Supplies	9-21
Supplies List	9-21
Supplies	9-23
Marker Pens Compatible with the CFX Series	9-31
License Library (EPL5 StarterWare)	9-33

DISCLAIMERS

- MIMAKI ENGINEERING REJECTS ALL LIABILITY FOR DAMAGE ARISING DIRECTLY OR INDIRECTLY FROM THE USE OF THE CFX (“THIS MACHINE” HEREINAFTER), WHETHER OR NOT THE PRODUCT IS FAULTY.
- MIMAKI ENGINEERING REJECTS ALL LIABILITY FOR DAMAGE, DIRECT OR INDIRECT, TO MATERIALS CREATED WHILE USING THIS MACHINE.
- USING THIS MACHINE IN CONJUNCTION WITH DEVICES OTHER THAN THOSE RECOMMENDED BY MIMAKI ENGINEERING MAY RESULT IN FIRE OR ACCIDENTS. SUCH INCIDENTS ARE NOT COVERED BY THE PRODUCT WARRANTY. MIMAKI ENGINEERING REJECTS ALL LIABILITY FOR DAMAGE, DIRECT OR INDIRECT, ARISING FROM SUCH INCIDENTS.
- USE ONLY GENUINE MIMAKI ENGINEERING TOOLS AND PARTS. USE OF OTHER PRODUCTS MAY RESULT IN FAILURES OR REDUCE CUT QUALITY. SUCH INCIDENTS ARE NOT COVERED BY THE PRODUCT WARRANTY. MIMAKI ENGINEERING REJECTS ALL LIABILITY FOR DAMAGE, DIRECT OR INDIRECT, ARISING FROM SUCH INCIDENTS.

TV and Radio Interference

In use, the machine emits high-frequency electromagnetic radiation. If installed or used incorrectly, this may result in TV or radio interference. Accordingly, there is no assurance that the machine will not affect special radio or TV equipment.

If you believe the machine is interfering with radio/TV reception, turn it off to investigate. If the interference disappears when the power is turned off, the machine is likely to be the cause of the interference.

Try any of the following solutions or combinations of these solutions:

- Change the orientation of the TV or radio antenna to find a position where interference does not occur.
- Place TVs or radios away from the product.
- Plug TVs or radios into outlets on a different power supply path than the product.

Usage Restrictions

Usage Restrictions

The machine can be dangerous due to parts that move at high speeds and parts with high temperature. This machine is to be used only by those having complete understanding of dangers associated with these parts.

User Restrictions

Users of the machine must be properly trained. Restrict the operation of the machine to properly trained users.

Area Restrictions

- Only adequately trained and versed individuals are allowed to come closer to the equipment. Set area restrictions within the ranges shown in the figures for “CFX-2513”, “CFX-2531” on page vii, and “CFX-2550” on page viii. As for the method of area restriction, the machine should be installed in a dedicated room or enclosed for everyone to understand that it is a hazardous area.
- Follow EN ISO13857 standards when securing the area with safety fence.
- When installing the setup in a dedicated room, install locks and interlocks on the door of the room, and lastly conduct risk assessment at the installation site before use.

Voluntary restraint of electromagnetic interference

This product is VCCI Class A information technology equipment. Use of the machine in a residential environment may cause interference.

Such incidents may require the user to take appropriate measures.

VCCI-A

CFX-2513

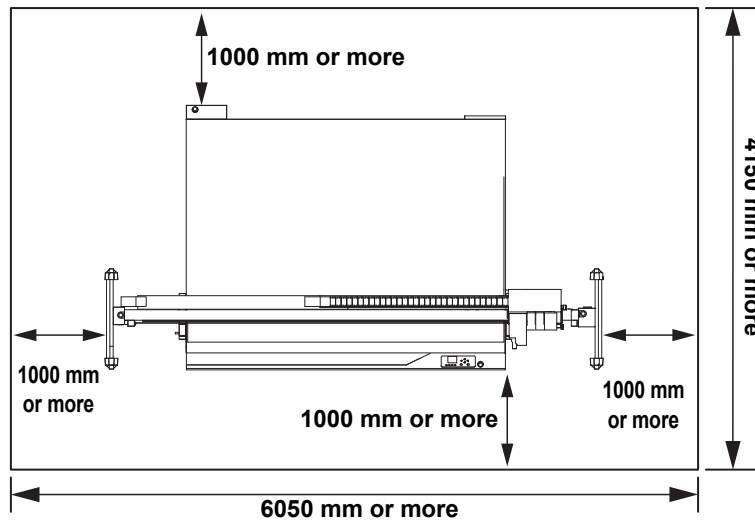

CFX-2531

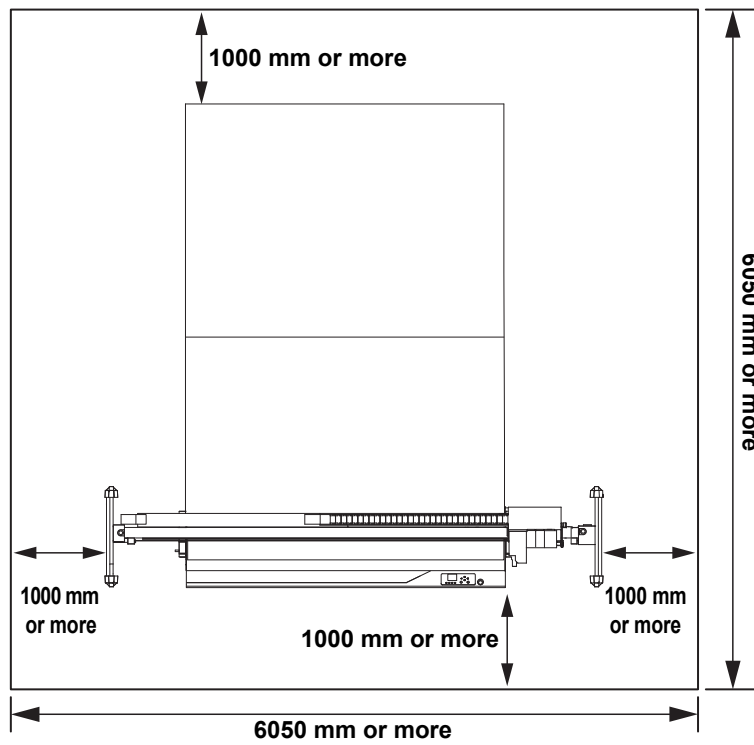

CFX-2550

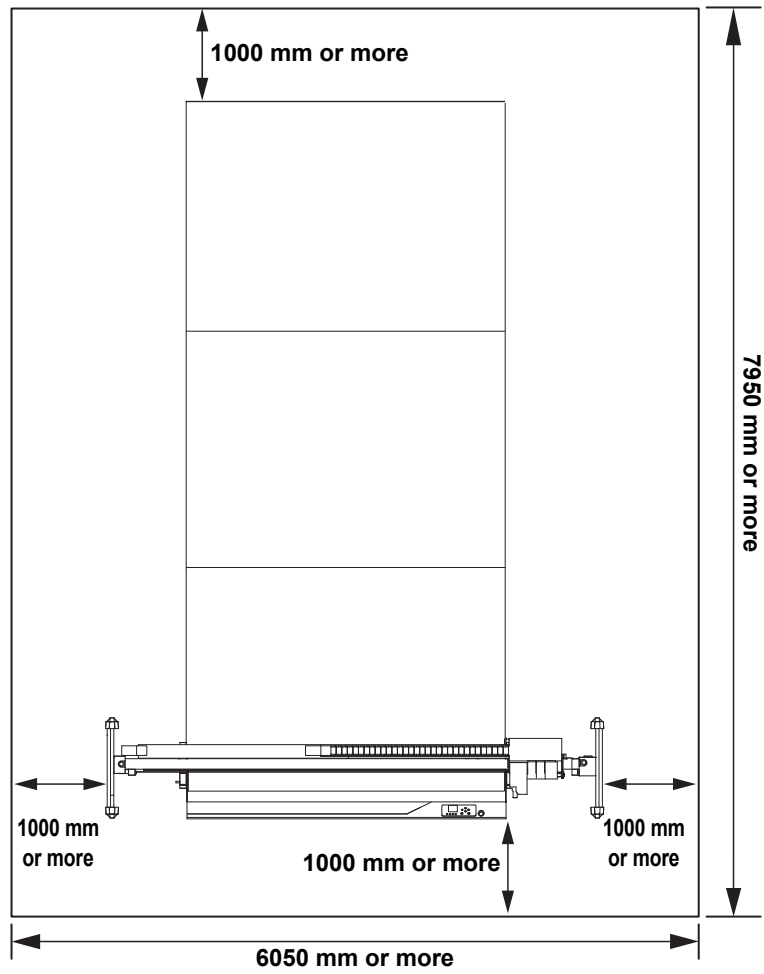

Introduction

Thank you for purchasing a CFX Series flatbed cutting plotter.

This manual describes the CFX Series.

Read this manual carefully and make sure you understand it before use. Keep the manual in a convenient place for reference as needed.

About This Operation Manual

- This manual describes the operation, maintenance, and other handling of CFX Series flatbed cutting plotters (“the machine”).
- Read this manual carefully and make sure you understand it before use. Keep the manual in a convenient place for reference as needed.
- Ensure that the manual reaches the person using the machine.
- Although every effort has been made to ensure the accuracy of the information in this manual, if you find any issues, contact our service office.
- This manual is subject to change without notice for improvement.
- You can also download the latest manual from our website.



- The machine uses sharp blades. It can be very hazardous during operation. Never put your hands or head near the machine head. There is a risk of injury.

Unit abbreviations

The following abbreviations may appear in titles and elsewhere in the manual.

No.	Abbreviation	Name
(1)	TUT-15	Tangential unit
(2)	TUT-30	High-pressure tangential unit
(3)	R10	Router unit

Accessories

Confirm that all accessories have been included. (☞ P.9-8)

If any accessories are missing or damaged, contact a dealer or our sales office.

Unauthorized reproduction of any portion of this document is strictly prohibited.

© Mimaki Engineering Co., Ltd.











All rights reserved.



















Safety Precautions

Symbols

In this manual, symbols indicate and explain precautions. The indicated symbol varies depending on the nature of the precaution. Make sure you understand the meaning of each symbol and use the machine safely and correctly.

Examples of symbols

	Explanation
	Failure to observe the instructions given with the [Warning] symbol may result in death or serious injuries to personnel. Be sure to read the precaution carefully and use the machine correctly.
	Failure to observe the instructions given with the [Caution] symbol may result in injury to personnel or damage to property.
	Important notes regarding use of the machine are given with the [Important] symbol. Use as reference information.
	Useful information is given with the [Tip] symbol. Use as reference information.
	Indicates the corresponding page for related information.
	The  symbol indicates precautions (including danger and warning items) that must be followed. Specific precautions are shown in the figure, as in the warning of electric shock shown at left.
	The  symbol indicates prohibited actions. Specifically prohibited actions are shown in or near the figure, as in the prohibition of disassembly shown at left.
	The  symbol indicates actions that must be taken or instructions that must be followed. Specific instructions are shown in the figure, as in holding cords by the plug when unplugging them, shown at left.

 Warning	
<p>Do not disassemble or modify</p>  <ul style="list-style-type: none"> • Never disassemble or modify plotter main unit or vacuum unit. Disassembling or modifying will result either in electric shock or malfunction of this machine. 	<p>Handling of cables</p>  <ul style="list-style-type: none"> • Do not attempt to modify power or communication cables, and avoid damaging or breaking them. Placing heavy objects on, heating, or pulling the cable may damage it, which may result in fire or electric shock.
<p>Do not use in humid environments</p>  <ul style="list-style-type: none"> • Do not use in humid environments, and do not splash water on the equipment. Failure to observe these instructions may result in fire, electric shock, or failure. 	<p>Handling of tools</p>  <ul style="list-style-type: none"> • Store cutter holders and blades out of the reach of children. Do not place cutter holders or blades on the tray by the operating panel.
<p>When a problem occurs</p>   <ul style="list-style-type: none"> • Use of the machine under an abnormal condition, as when it is emitting smoke or fumes, may result in fire or electric shock. Turn off the power switch immediately, and then be sure to unplug the machine from the outlet. Once you have confirmed that smoke is no longer being emitted, request repair from your dealer or service office. Never attempt to repair the machine yourself, which is hazardous. 	<p>Power supply and voltage</p>   <ul style="list-style-type: none"> • The machine contains parts that generate high voltage. Electrical work by individuals other than licensed electricians is prohibited. • To prevent electric shocks during maintenance, always turn the main power switch off, and remove the power plug. Capacitors of some units may take one minute to discharge. Before maintenance, always wait 3 minutes after turning off the main power supply switch and disconnecting the power inlet. • Always ground the machine to prevent electric shock, because there is significant leakage current. • Use a power supply that meets the power supply specifications. Always plug the power cable into a grounded socket. Failure to observe these instructions may result in fire or electric shock. • The task of turning on the main power supply switch of the machine should be performed only by personnel who are thoroughly familiarity with using the machine.
<p>Entrust maintenance to service engineers</p>  <ul style="list-style-type: none"> • In the event of failure, entrust maintenance work to service engineers. Never perform maintenance work by yourself, which poses risks including electric shock. 	 
<p>Handling of the power cable</p>  <ul style="list-style-type: none"> • Use the power cable provided. • Do not attempt to modify the cable, and avoid damaging or breaking it. Placing heavy objects on, heating, or pulling the cable may damage it, which may result in fire or electric shock. 	 <ul style="list-style-type: none"> • The task of turning on the main power supply switch of the machine should be performed only by personnel who are thoroughly familiarity with using the machine.
<p>Preventive measures against dust</p>  <ul style="list-style-type: none"> • When handling dust-producing substance that pose health hazards, wear a mask or take other protective measures. 	<p>Grounding work</p>  <ul style="list-style-type: none"> • The machine must be grounded to protect against electric shock. • Ground in accordance with Class C grounding work, formerly Type 3 grounding work.
<p>Handling of grease</p>  <ul style="list-style-type: none"> • If grease enters a user's eyes, wash with clean water for 15 minutes and seek medical attention. • If grease gets on skin or clothing, wipe it off well and wash thoroughly with water and soap. • If you feel ill after inhaling a large amount of vapor, go to a place with fresh air, rest under a blanket or the like to stay warm, and seek medical attention. • If grease is accidentally ingested, seek medical attention immediately without inducing vomiting. • In case of fire involving grease, initially use extinguishing agents such as powder, carbon dioxide, or dry sand. For large fires, use foam extinguishers to block out air around the fire. Evacuate people not involved in firefighting to a safe place. • Do not use water to extinguish grease fires, because this is hazardous and may cause the fire to spread. • Wear protective equipment when fighting fires. Fight fires from upwind. 	
<p>Safety measures</p> <p>Take the following safety measures when working with flammable materials.</p> <ul style="list-style-type: none"> • Before working with these materials, make sure that wood chips or other remains are removed. • Do not leave the machine unattended while it is in use. • Keep a fire extinguisher nearby. • Keep flammable materials away from the machine. 	



Warning

Machine disposal



- Request an industrial waste disposal company to dispose of the machine.
- Dispose of in accordance with local regulations.

Other usage precautions



- Keep children away from this machine.

For safe operation



Caution

Do not place heavy objects on cables



- Do not use force to bend the power or communication cable, and do not place heavy objects on them. Failure to observe these instructions may break the cables, cause electric shock, generate heat, or cause fires.

Wait 30 seconds before restoring power



- Wait 30 seconds before turning the machine on again after it is turned off. Failure to observe these instructions may result in malfunctioning.

Do not sit on the main unit



- Do not sit on the main unit. This may lead to failure.

Keep your face away from the cutting panel during use



- Keep your face and hands away from the cutting panel during cutting or drawing. Failure to observe this precaution poses a risk of injury from the cutter.

Do not work while wearing baggy clothing or jewelry



- Do not wear baggy clothes or fashion accessories while working. Keep long hair bound.

Contact Mimaki before moving the plotter to another location



- Plotters are precision instruments. Contact Mimaki in advance if you will move the plotter to another location.

Do not operate the vacuum when all suction area range selection valves are closed



- Do not operate the vacuum when all suction area range selection valves are closed. Doing so may result in failure.

Use hearing protection when operating in reverberant environments or for extended periods of time



- The operating noise level may increase during use, exceeding 70 dB near the vacuum unit. We recommend using hearing protection, such as earplugs or earmuffs, in reverberant environments or during prolonged use.

For safe installation



Caution

Caution	
Exposed to direct sunlight	Where vibration occurs
<ul style="list-style-type: none"> Do not install where direct sunlight or the like will cause the cutting panel surface temperature to exceed 60°C. Failure to observe this precaution may result in deformation of the cutting panel or failure. 	<ul style="list-style-type: none"> Normal results cannot be obtained where vibration occurs.
Exposed to significant changes in temperature or humidity	Dusty, dirty, or smoky environments
<ul style="list-style-type: none"> Use the machine under the following environmental conditions: Operating environment: 10° to 35°C, 35% to 75% (RH) 	<ul style="list-style-type: none"> Plotters are precision instruments. Do not use in areas filled with dust or dirt.
Exposed to direct air flow from an air conditioner or similar location	Near flammable materials
<ul style="list-style-type: none"> Cutting quality may be adversely affected. 	<ul style="list-style-type: none"> Do not place flammable materials near the vacuum or in front of the exhaust area, because exhaust air becomes very hot when the vacuum is used.
Places with uneven surfaces	Places with open flame
<ul style="list-style-type: none"> Normal results cannot be obtained unless the plotter is level. Failure to observe these instructions may also result in failure. 	<ul style="list-style-type: none"> Do not place vases, pot plants, cups, cosmetics, containers of chemicals or water, or small metal objects on top of this machine. There is a risk of failure, electric shock, or fire if liquids or items drop inside the machine.

Warning Labels

Warning labels have been applied to the machine. Make sure you fully understand the details indicated on the various warning labels.

If a warning label is illegible due to stains or has come off, purchase a new one from a dealer or our service office.

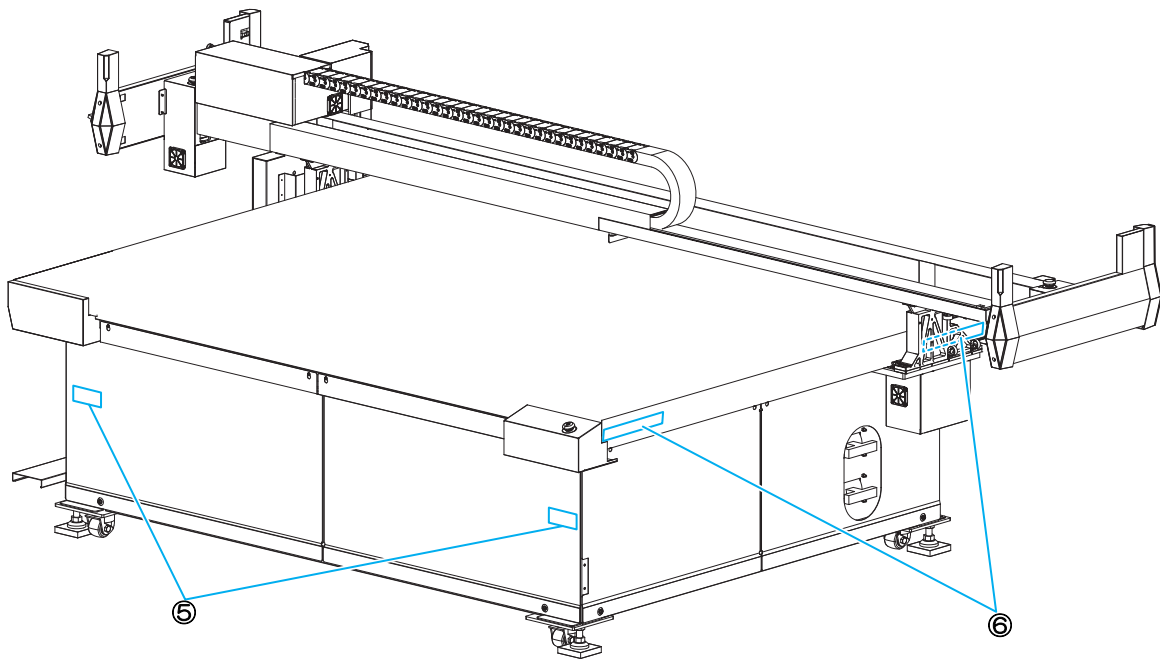
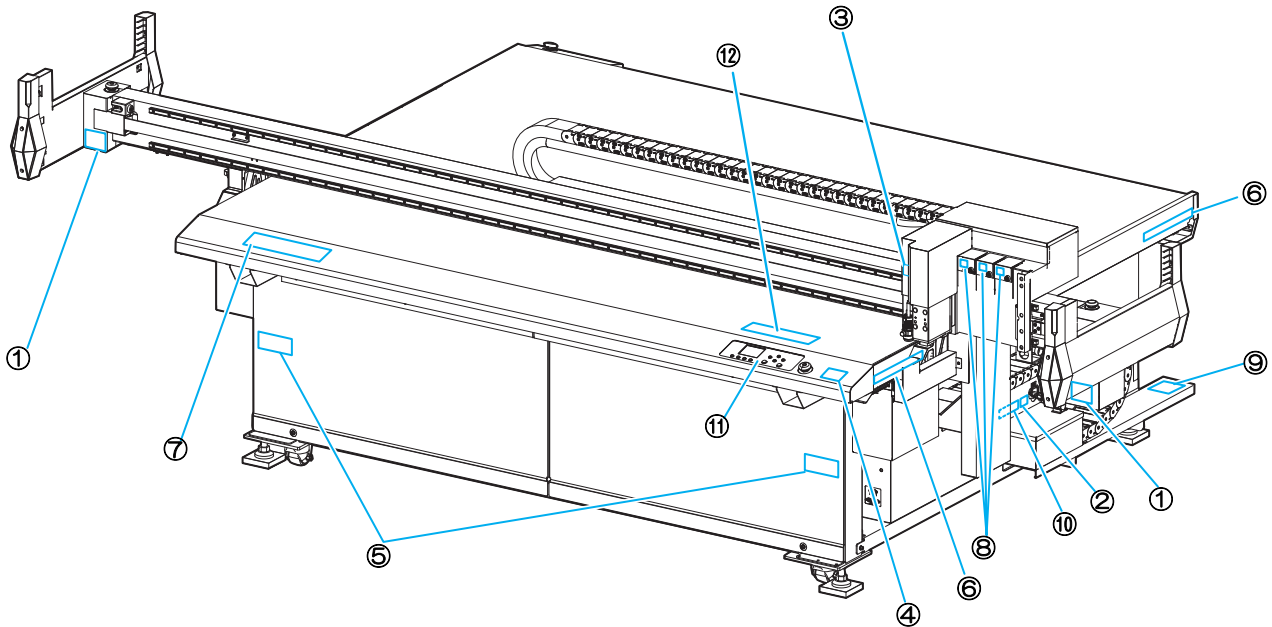

Optional accessories

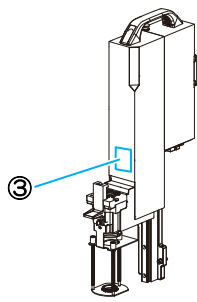

Tangential unit (TUT-15)

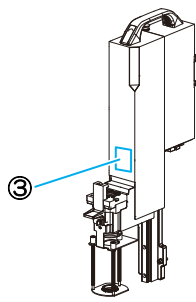

High-pressure tangential unit (TUT-30)

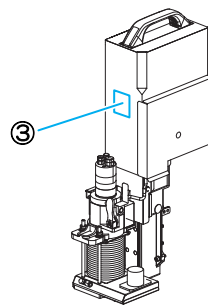



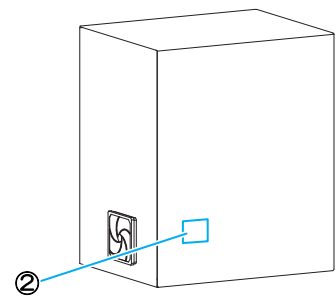

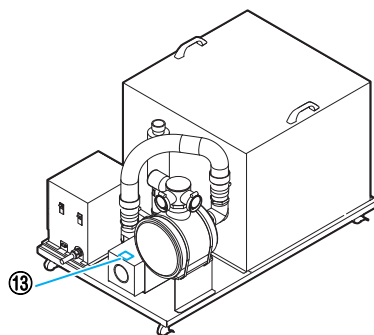

Router unit (R10)



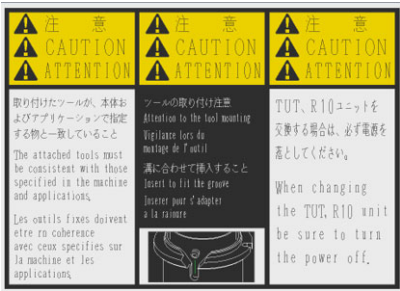

Router unit electrical box

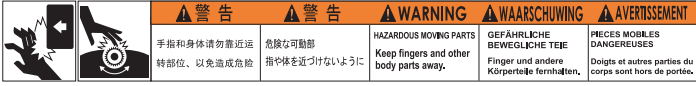

7.5kW / 8.6kW Vacuum Unit

No.	Order code	Label	Details
1	M902667		PL label Be careful around moving parts. Failure to observe these instructions may result in injury.
2	M907935		Hazardous high voltage inside.
3	M905694		Be careful around the blade.
4	M919761		Advises cautions regarding tool installation.
5	M909381		Keep fingers and body away from moving parts to avoid injury.
6	M906115		Keep fingers and body away from moving parts to avoid injury.
7	M902663		Keep fingers and face away from the machine when the head is moving and when the machine is in remote mode, to avoid injury.
8	M918910		Attach the cover if an optional unit is not used.

9	M909385		Prohibits putting feet on the indicated place.				
10	M905624	<table border="1" data-bbox="485 394 1015 524"> <tr> <td>⚠ 警告 漏えい電流大 電源へ接続する前に 接地接続が必要</td> <td>⚠ WARNING HIGH LEAKAGE CURRENT EARTH CONNECTION ESSENTIAL BEFORE CONNECTING SUPPLY</td> </tr> <tr> <td>⚠ AVERTISSEMENT COURANT DE FUITE ELEVE CONNECTER LA MISE A LA TERRE AVANT DE CONNECTER L'ALIMENTATION</td> <td>⚠ WARNUNG HOHER KRIECHSTROM BITTE ERDKABEL ANSCHLIESSEN BEVOR SIE STROMZUFUHR ANSCHLIESSEN</td> </tr> </table>	⚠ 警告 漏えい電流大 電源へ接続する前に 接地接続が必要	⚠ WARNING HIGH LEAKAGE CURRENT EARTH CONNECTION ESSENTIAL BEFORE CONNECTING SUPPLY	⚠ AVERTISSEMENT COURANT DE FUITE ELEVE CONNECTER LA MISE A LA TERRE AVANT DE CONNECTER L'ALIMENTATION	⚠ WARNUNG HOHER KRIECHSTROM BITTE ERDKABEL ANSCHLIESSEN BEVOR SIE STROMZUFUHR ANSCHLIESSEN	Be sure to ground the machine, in consideration of the high leakage current.
⚠ 警告 漏えい電流大 電源へ接続する前に 接地接続が必要	⚠ WARNING HIGH LEAKAGE CURRENT EARTH CONNECTION ESSENTIAL BEFORE CONNECTING SUPPLY						
⚠ AVERTISSEMENT COURANT DE FUITE ELEVE CONNECTER LA MISE A LA TERRE AVANT DE CONNECTER L'ALIMENTATION	⚠ WARNUNG HOHER KRIECHSTROM BITTE ERDKABEL ANSCHLIESSEN BEVOR SIE STROMZUFUHR ANSCHLIESSEN						
11	M918881		Standby label				
12 ^{*1}	M915322	<table border="1" data-bbox="416 730 1082 860"> <tr> <td>⚠ 警告 可燃性の材料を加工する際は、以下の安全対策を必ずしてください。 • 未燃の加工残屑は、加工開始前に排棄し取り除いてください。 • 稼働中の機械から離れないでください。 • 近くに消火器を用意してください。 • 機械の近くに可燃性の材料を置かないでください。</td> <td>⚠ WARNING When processing flammable materials, please take the following safety measures. - Be sure to remove processing residues such as wood chips before starting processing. - Do not leave the machine in operation without operator. - Prepare a fire extinguisher nearby. - Do not place flammable materials near the machine.</td> </tr> <tr> <td>⚠ AVERTISSEMENT Lors du traitement de matériaux inflammables, veuillez prendre les mesures de sécurité suivantes. - Essayer de retirer les résidus de traitement, dès que les copeaux de bois ont commencé à tomber. - Ne pas laisser la machine en fonctionnement sans opérateur. - Préparer un extincteur à proximité. - Ne pas placer de matériaux inflammables à proximité de la machine.</td> <td>⚠ WARNUNG Bitte treffen Sie bei der Verarbeitung von brennbaren Materialien die folgenden Vorkehrungen. - Entfernen Sie unbedingt Rückstände wie etwa Holzspäne, bevor Sie die Verarbeitung beginnen. - Lassen Sie die Maschine nicht ohne Bediener in Betrieb. - Halten Sie einen Feuerlöscher in der Nähe bereit. - Lagern Sie keine brennbaren Materialien in der Nähe der Maschine.</td> </tr> </table>	⚠ 警告 可燃性の材料を加工する際は、以下の安全対策を必ずしてください。 • 未燃の加工残屑は、加工開始前に排棄し取り除いてください。 • 稼働中の機械から離れないでください。 • 近くに消火器を用意してください。 • 機械の近くに可燃性の材料を置かないでください。	⚠ WARNING When processing flammable materials, please take the following safety measures. - Be sure to remove processing residues such as wood chips before starting processing. - Do not leave the machine in operation without operator. - Prepare a fire extinguisher nearby. - Do not place flammable materials near the machine.	⚠ AVERTISSEMENT Lors du traitement de matériaux inflammables, veuillez prendre les mesures de sécurité suivantes. - Essayer de retirer les résidus de traitement, dès que les copeaux de bois ont commencé à tomber. - Ne pas laisser la machine en fonctionnement sans opérateur. - Préparer un extincteur à proximité. - Ne pas placer de matériaux inflammables à proximité de la machine.	⚠ WARNUNG Bitte treffen Sie bei der Verarbeitung von brennbaren Materialien die folgenden Vorkehrungen. - Entfernen Sie unbedingt Rückstände wie etwa Holzspäne, bevor Sie die Verarbeitung beginnen. - Lassen Sie die Maschine nicht ohne Bediener in Betrieb. - Halten Sie einen Feuerlöscher in der Nähe bereit. - Lagern Sie keine brennbaren Materialien in der Nähe der Maschine.	Take safety measures when working with flammable materials.
⚠ 警告 可燃性の材料を加工する際は、以下の安全対策を必ずしてください。 • 未燃の加工残屑は、加工開始前に排棄し取り除いてください。 • 稼働中の機械から離れないでください。 • 近くに消火器を用意してください。 • 機械の近くに可燃性の材料を置かないでください。	⚠ WARNING When processing flammable materials, please take the following safety measures. - Be sure to remove processing residues such as wood chips before starting processing. - Do not leave the machine in operation without operator. - Prepare a fire extinguisher nearby. - Do not place flammable materials near the machine.						
⚠ AVERTISSEMENT Lors du traitement de matériaux inflammables, veuillez prendre les mesures de sécurité suivantes. - Essayer de retirer les résidus de traitement, dès que les copeaux de bois ont commencé à tomber. - Ne pas laisser la machine en fonctionnement sans opérateur. - Préparer un extincteur à proximité. - Ne pas placer de matériaux inflammables à proximité de la machine.	⚠ WARNUNG Bitte treffen Sie bei der Verarbeitung von brennbaren Materialien die folgenden Vorkehrungen. - Entfernen Sie unbedingt Rückstände wie etwa Holzspäne, bevor Sie die Verarbeitung beginnen. - Lassen Sie die Maschine nicht ohne Bediener in Betrieb. - Halten Sie einen Feuerlöscher in der Nähe bereit. - Lagern Sie keine brennbaren Materialien in der Nähe der Maschine.						
13	M903239		Indicates hot parts.				

*1. Included with purchase of R10 option.

Chapter 1

Setup



About this chapter

This chapter describes information essential before use, such as part names.

Installation.....	1-2	Setting the Vacuum.....	1-23
Vacuum (Optional) Installation Position	1-5	What is a vacuum unit?	1-23
Moving the Machine	1-5	Enabling/Disabling Auto Vacuum Off	1-23
Part Names and Functions	1-6	Interlock between Remote Key and Vacuum	1-25
Main Unit	1-6	Setting the Camera Unit.....	1-26
Head	1-7	Camera Unit Overview	1-26
Electrical Box Side	1-8	Camera Settings	1-26
Vacuum Unit Electrical Box (Optional)	1-9	Adjusting Camera Image Quality	1-26
Head Side (When Equipped with Option/R10)	1-9		
Operating Panel	1-10		
Display	1-11		
Cable Connections.....	1-14		
Connecting the Power Cable	1-14		
Connecting Interface Cables	1-14		
Local/Remote Mode.....	1-15		
Local Mode and Corresponding Display ...	1-15		
Remote Mode and Corresponding Display	1-15		
Emergency Stop	1-16		
Using Emergency Stop	1-16		
Resetting an Emergency Stop	1-16		
Preparing the Cutting Panel.....	1-18		
Attaching the Work Guides	1-18		
Matching the Plotter Specifications.....	1-21		
Setting Automatic Head Retraction.....	1-22		

Installation

Install the machine in a location where the following installation space is available.



- Keep the installation space free of other objects. These may cause you to trip.
- The exhaust from the vacuum unit can get very hot. Do not place any objects near the exhaust outlet.

Model	Width	Depth	Height	Gross weight	Installation space
CFX-2513	4050 mm	2150 mm	1500 mm	Approximately 440 kg	4,150mm×6,050mm or more
CFX-2531	4050 mm	4050 mm	1500 mm	Approximately 660 kg	*6,050mm×6,050mm or more
CFX-2550	4050 mm	5950 mm	1500 mm	Approximately 880 kg	*6,050mm×7,950mm or more

* In toggle mode, it can be set to any position. However, please note the following:

- Do not set it within the Y-bar's range of motion.
- Install it in a location that allows for easy piping connection.
- Install it on the manual valve side.
- Position it so that the exhaust does not affect the surrounding area.

For CFX-2513

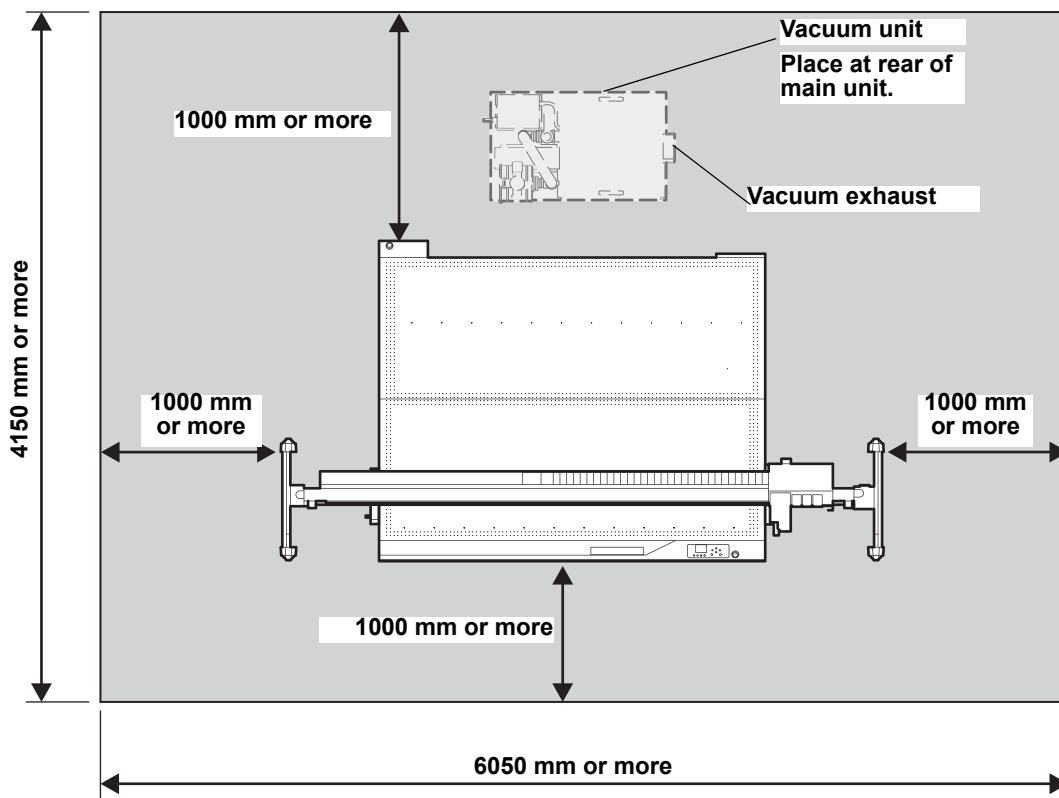

For CFX-2531

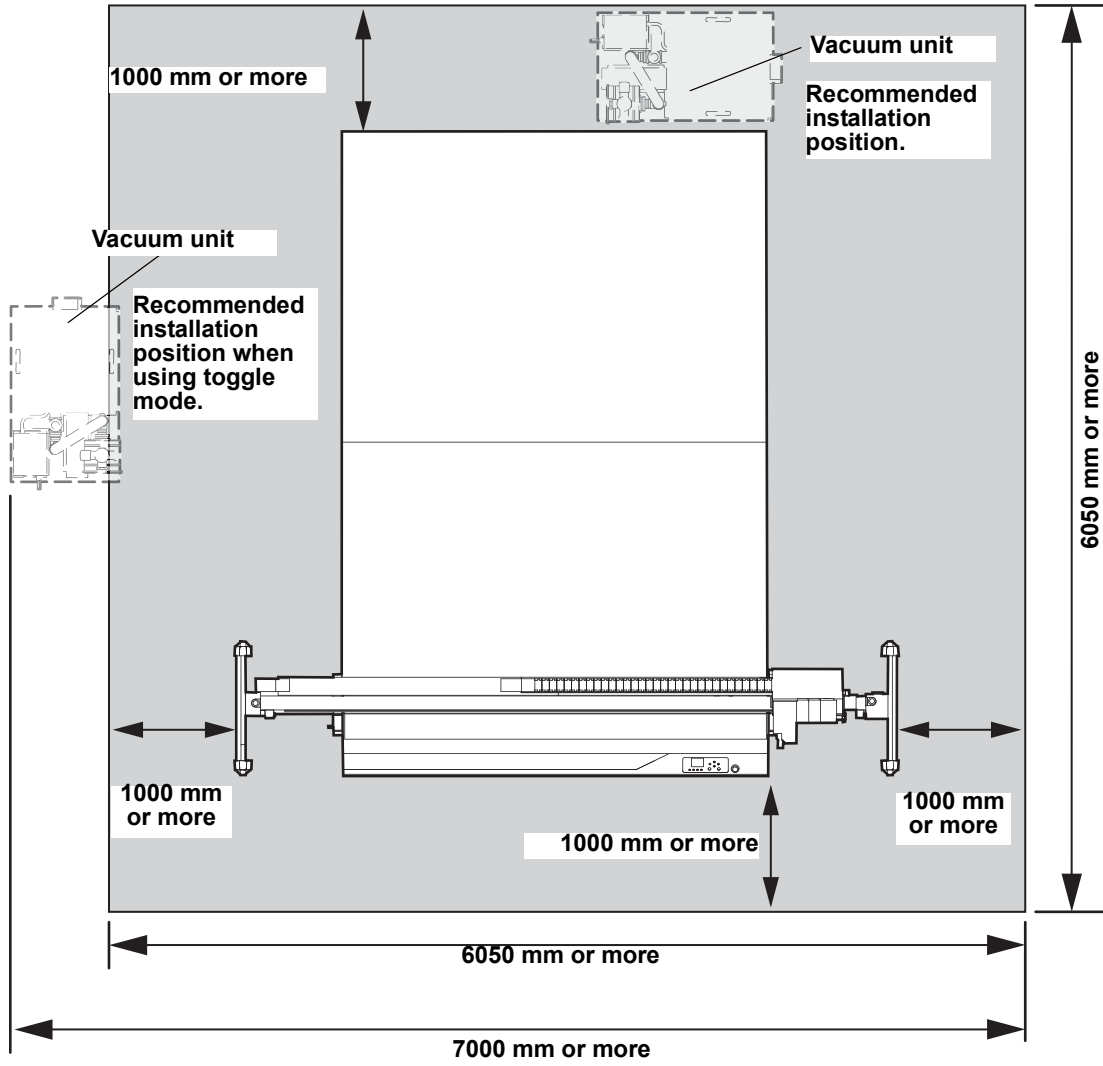

1

For CFX-2550

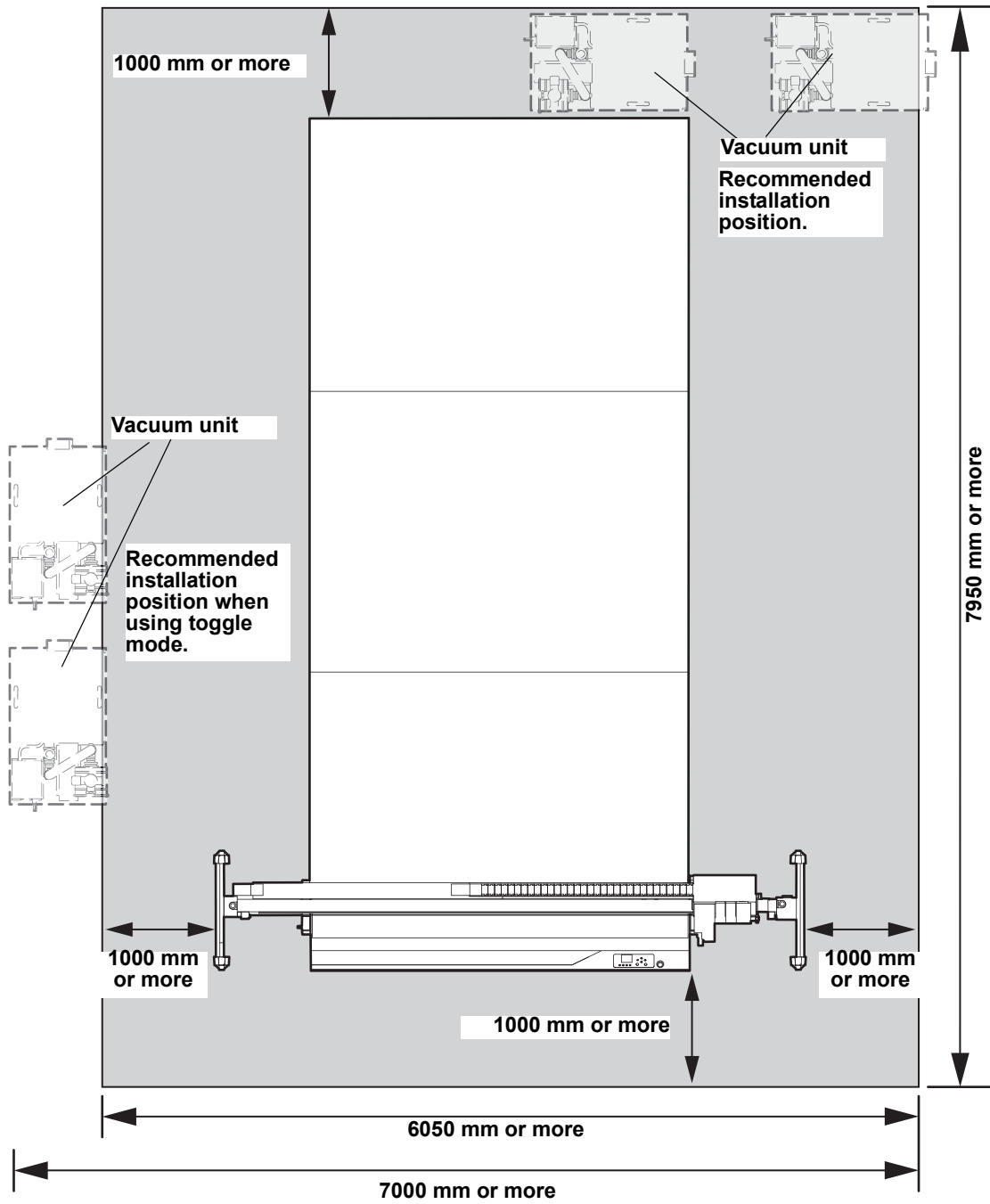

Vacuum (Optional) Installation Position

As shown in the diagram on the previous page, install the vacuum at the rear of the main unit.



- The vacuum unit body and exhaust air become hot. Do not place flammable objects or material near the vacuum unit or in the direction of exhaust.
- Be careful to avoid burns, because the vacuum unit will remain hot for a while even after it is stopped.
- Turn off the vacuum unit when pausing work.
- Avoid blocking the vacuum exhaust port or placing objects near the exhaust port, which will increase the internal temperature and may lead to failure.
- Do not operate the vacuum when all suction area range selection valves are closed. Doing so may result in failure.
- For the OPT-01035 7.5 kW Vacuum Unit (200 V) and the OPT-01036 7.5 kW Vacuum Unit (400 V), the soundproof box's cooling fan operates for ten minutes after vacuum operation stops. Ensure that the cooling fan operates normally during vacuum operation. If the cooling fan does not operate during vacuum operation, discontinue use immediately. There may be a malfunction in the equipment.
- The intake noise from the vacuum unit's relief valve increases as the suction area for work on the cutting panel increases.
- The operating noise level may increase during use, exceeding 70 dB near the vacuum unit. We recommend using hearing protection, such as earplugs or earmuffs, in reverberant environments or during prolonged use.
- When using the OPT-1037 Toggle Unit, you may hear a high-pitched airflow noise when you stop the vacuum operation. This is normal.

Moving the Machine

If you must move the machine on the same floor (assuming that the floor is flat), do the following.



- Before moving the machine, contact our sales office or your dealer. Attempting to move the machine by yourself may lead to failure or damage. Entrust moving the machine to professionals.



- Avoid significant vibration when the machine is moved.
- After the machine is moved, use the level foot to level the machine.

Part Names and Functions

Main Unit

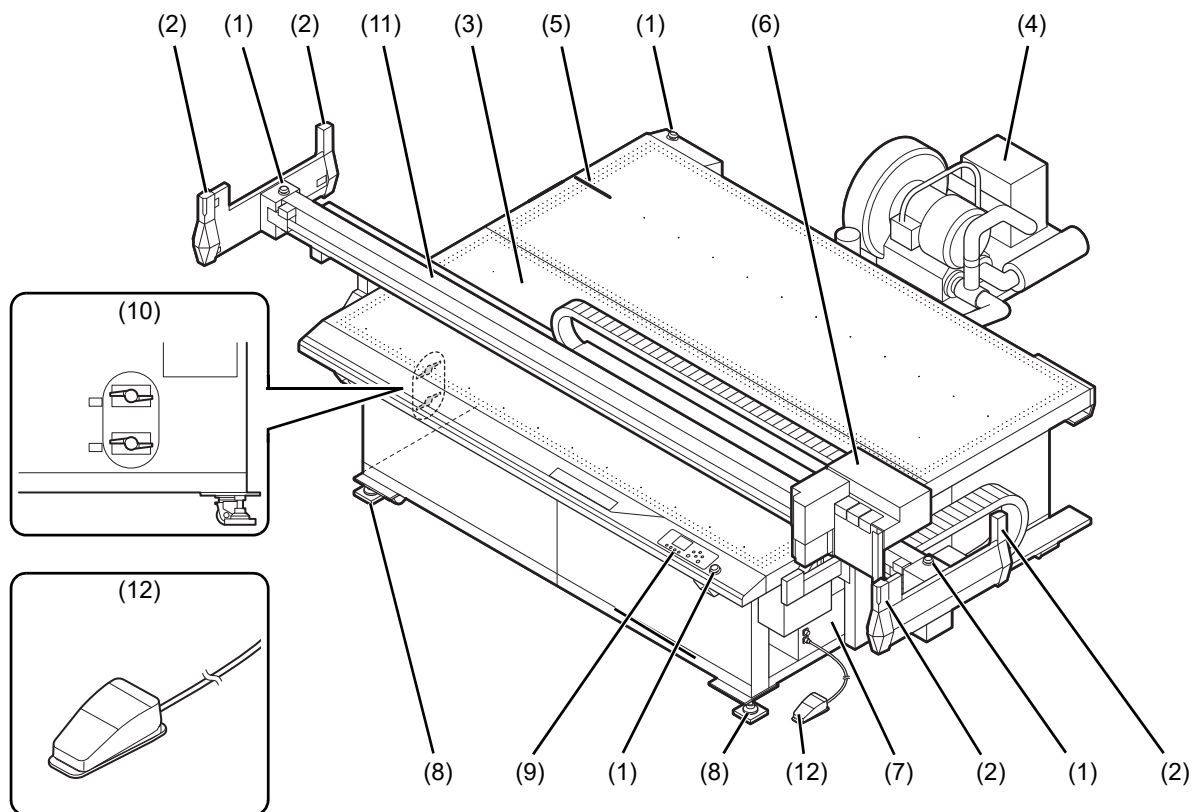

No.	Name	Function
(1)	Emergency switch	Press in case of emergency. Forces the power off and stops operation.
(2)	Safety sensors	Detects operators or obstructions within the head range of motion.
(3)	Cutting panel (felt mat)	Holds the work. Features a regular array of small holes for vacuum adhesion. The felt mat is placed here.
(4)	Vacuum unit (optional)	The work is held by suction against the cutting panel.
(5)	Work guide	Place the work against the guide to set it up straight.
(6)	Head	Holds various tools. Tools you can install vary depending on the unit.
(7)	Electrical box	Contains PCBs and other components.
(8)	Adjuster foot	Used to adjust the height of the legs as needed to keep the cutting panel surface level.
(9)	Operating panel	Used to configure necessary settings for the machine.
(10)	Suction area range selection valve	Used to select the suction area, by opening or closing the valve.
(11)	Y-bar	Moves the head in the Y direction.
(12)	Foot switch ^{*1}	Depressed with your foot to switch the vacuum suction on and off.

*1: For CFX-2513, an optional part. Included with CFX-2531/2550.

Head

Front

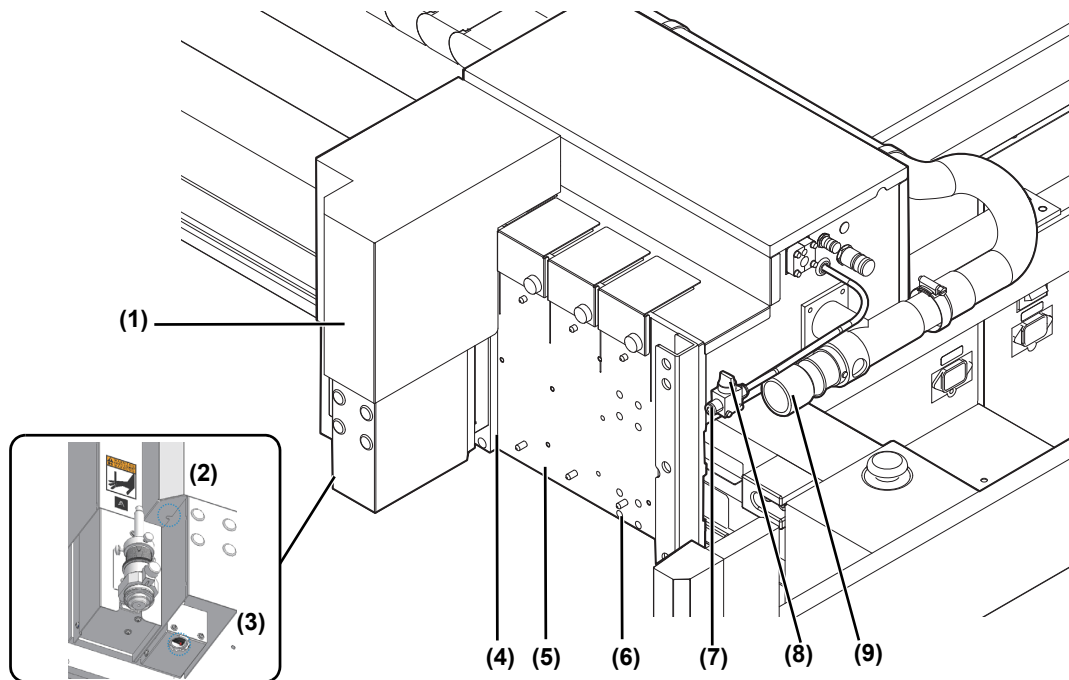

1

	Name	Function
(1)	Station A	A pen or swivel cutter is mounted on the standard unit.
(2)	LED pointer	Used for alignment or setting the origin for reading register marks.
(3)	Mark sensor	Sensor for detecting register marks.
(4)	Station B	Used for mounting a tangential unit.
(5)	Station C	Used for mounting a tangential unit.
(6)	Station D	Used for mounting a tangential unit and router unit.
(7)	Auxiliary air connection port ^{*1}	For attaching a cleaning hose to supply auxiliary air.
(8)	Auxiliary air valve ^{*1}	Switches auxiliary air on/off (simple duster).
(9)	Router vacuum connection port ^{*1}	Vacuum connection port for router unit.

*1. Only included with R10.

Electrical Box Side

Interfaces

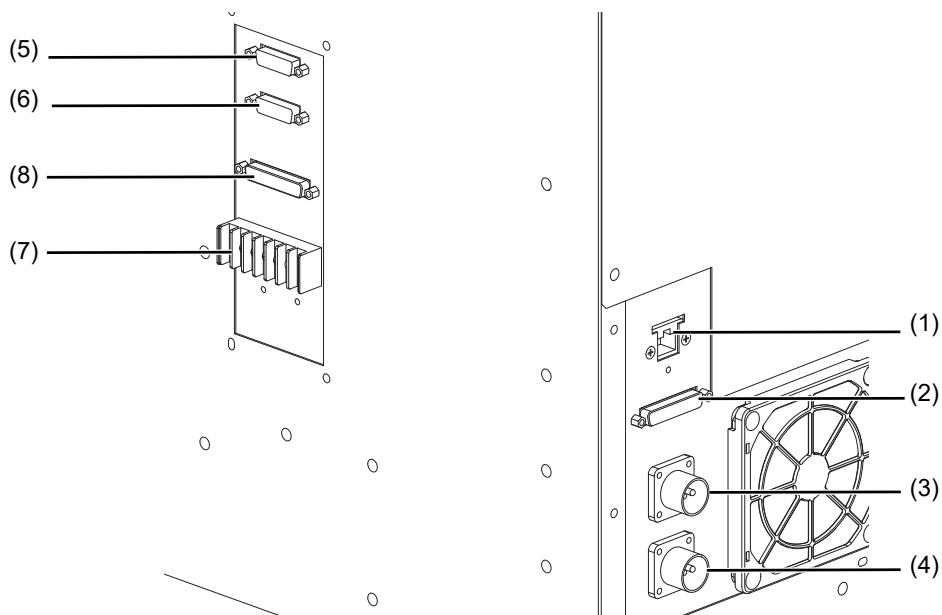

	Name	Function
(1)	Ethernet connector	Connect a computer using a LAN cable.
(2)	RS-232C interface	Connect a computer using an RS-232C interface cable.
(3)	Foot switch 1 port	Connect a foot switch.
(4)	Foot switch 2 port	Connect a foot switch.
(5)	Signal line connector 1 for vacuum	Connect an optional vacuum unit.
(6)	Signal line connector 2 for vacuum	Connect an optional vacuum unit.
(7)	External I/O terminal block	This is not used. Do not change the wiring.
(8)	Connector for optional accessories	Connect other optional units.

Main power supply

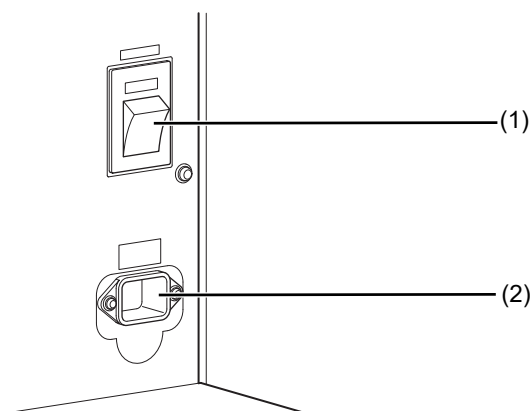

	Name	Function
(1)	Main power supply switch	For turning the machine's main power supply on/off. Normally, leave in the on position. Switch to off for maintenance.
(2)	Power inlet	Connect the plotter power cable.

Vacuum Unit Electrical Box (Optional)

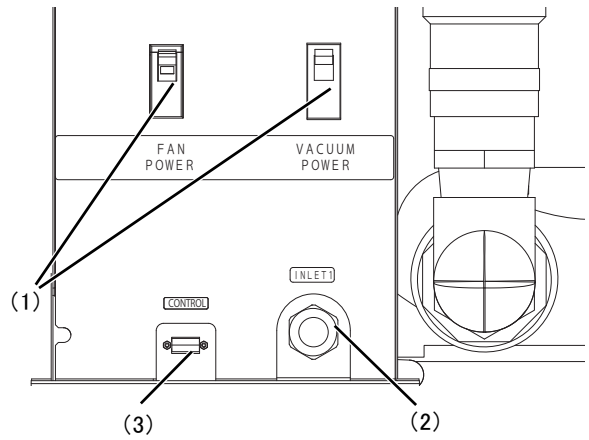

	Name	Function
(1)	Power switch	For turning the vacuum unit on/off. Normally, leave in the on position. Switch to off for maintenance. * The vacuum will not operate if the fan power switch is turned off.
(2)	Power Cable Ground	Connect the vacuum power cable.
(3)	Connector for control	Connect to the vacuum connector on the electrical box.

Head Side (When Equipped with Option/R10)

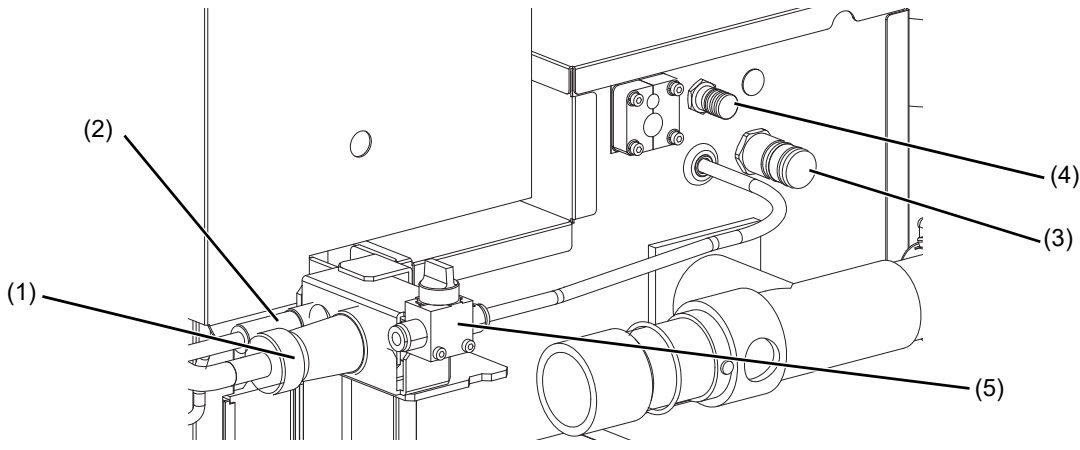

	Name	Function
(1)	Power Cable Ground	Connects the motor cable for R10.
(2)	Control connector	Connects the control cable for R10.
(3)	Cooling air tube connector	Connects the R10 cooling air tube.
(4)	Dust collector nozzle tube connector	Blows air inside the R10 dust collector brush.
(5)	Service air tube connector	Allows an air gun or similar to be connected.

Operating Panel

This is used to control the product and make/change settings.

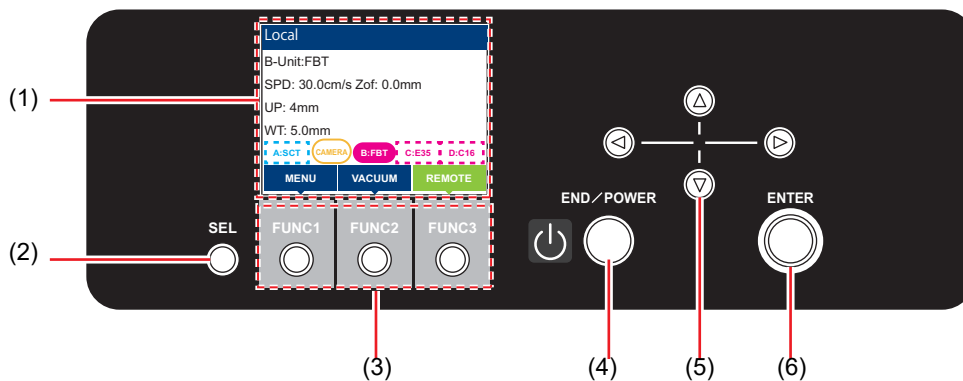

No.	Name	Overview
(1)	Display	☞ P.1-11 "Display"
(2)	[SEL] key	Selects the function for the corresponding [FUNCTION] key.
(3)	[FUNCTION] keys	Used for operations such as making test cuts, turning the vacuum on/off, or configuring various settings. ☞ P.1-13 "[FUNCTION] keys"
(4)	[END/POWER] key	Used to cancel the last setting entered, return to the previous level of the setting menu, or to turn power on/off. • To turn off the power, hold down the key. ☞ P.3-51 "Power OFF"
(5)	[JOG] key ▲ ▼ ◀ ▶	Used to move the head, enter values, or select various setting items.
(6)	[ENTER] key	Used to move to the next level menu and to confirm settings. • Lit in blue when the power is on. ☞ P.3-3 "Turning the Power On"

Display

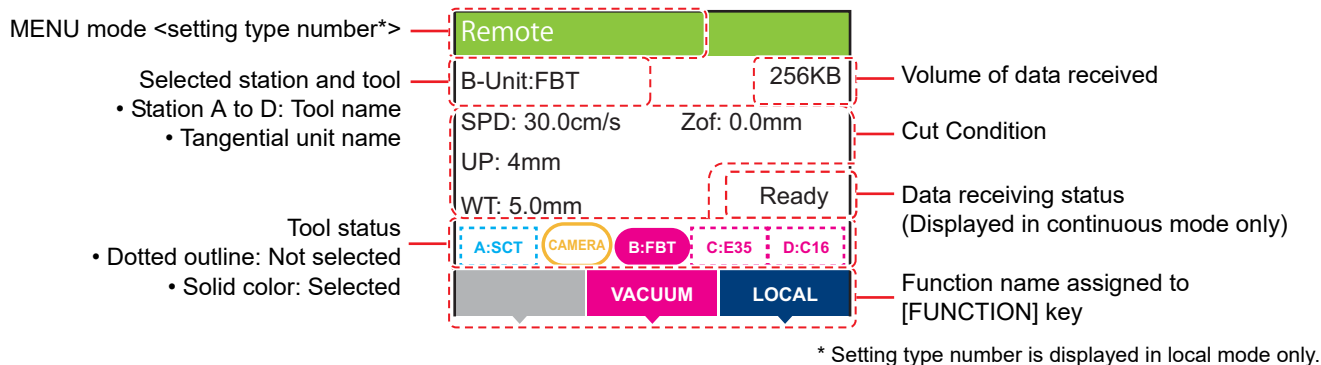

MENU mode

Four menu modes are available.

Name	Overview
LOCAL mode	Used to make test cuts, copy elements, or set various functions.
REMOTE mode	Used to cut the cut data received from a computer.
MENU mode	Press the [MENU] on the LOCAL mode screen to switch to MENU mode. This is used to set various functions.
JOG mode	Jog keys are used for plot origin setting, mark origin detection, work thickness setting, 2-point line correction, cut area setting, and other operations.

Tool status

Station A

Status	Tool	
	Eccentric Cutter	Pen
Not selected	A:SCT	A:PEN
Selected	A:SCT	A:PEN

Station B

Status	Tool							
	Flat blade tool	Reciprocating cutter E12	Reciprocating cutter E35	Reciprocating cutter E60	Crease roller C16	Crease roller C26	Crease roller C60	Crease tool C6A
Not selected	B:FBT	B:E12	B:E35	B:E60	B:C16	B:C26	B:C60	B:C6A
Selected	B:FBT	B:E12	B:E35	B:E60	B:C16	B:C26	B:C60	B:C6A

Status	Tool	
	V-cut V45	V-cut VAS
Not selected	B:V45	B:VAS
Selected	B:V45	B:VAS

Station C

Status	Tool							
	Flat blade tool	Reciprocating cutter E12	Reciprocating cutter E35	Reciprocating cutter E60	Crease roller C16	Crease roller C26	Crease roller C60	Crease tool C6A
Not selected	C:FBT	C:E12	C:E35	C:E60	C:C16	C:C26	C:C60	C:C6A
Selected	C:FBT	C:E12	C:E35	C:E60	C:C16	C:C26	C:C60	C:C6A

Status	Tool	
	V-cut V45	V-cut VAS
Not selected	C:V45	C:VAS
Selected	C:V45	C:VAS

Station D

Status	Tool							
	Flat blade tool	Crease roller C16	Crease roller C26	Crease roller C60	Crease tool C6A	V-cut V45	V-cut VAS	Router
Not selected	D:FBT	D:C16	D:C26	D:C60	D:C6A	D:V45	D:VAS	D:R10
Selected	D:FBT	D:C16	D:C26	D:C60	D:C6A	D:V45	D:VAS	D:R10

Mark detection selection tool

Status	Mark Detect
Mark sensor	SENSOR
Camera	CAMERA

Unit not installed

Status	Unit		
	B-Unit	C-Unit	D-Unit
Not installed	B-unit none	C-unit none	D-unit none

Data receiving status

This is displayed when using continuous mode.

Name	Overview
Not Ready	Waiting for work or data.
Ready	Work and data is ready, and waiting for a cutting queue number.
ID Reading	Detecting the data ID code. The status changes to "DataWaiting" once it is correctly detected. An error occurs if detection fails.
Drawing	Drawing has started. This also includes work thickness measurement.
DataWaiting	Waiting to receive the cut data after the data ID code has been detected. Or waiting for subsequent data after receiving an inquiry command, such as OH;. An error occurs if no data is received within 30 seconds after the data ID code was detected.
Work Change	Waiting for the work to be replaced after cutting has ended. Turning off the vacuum changes the status to "Not Ready".
Error	The error status is displayed if any of the following errors have occurred. New drawing is not possible in that area until the data has been cleared. <ul style="list-style-type: none"> •If a mark detection error or data ID code detection error occurs •If data is not sent after the data ID code has been detected •If the received data is too large

[FUNCTION] keys

This section describes the functions and roles assigned to the [FUNCTION] keys.

Icon	Name
MENU	Displays the various menu screens.
VACUUM	Turns vacuum operation on/off.
REMOTE	Used to switch from LOCAL mode to REMOTE mode screen.
TEST CUT	Displays the test cut selection screen.
COPY	Displays the screen for copying elements.
DATA CLEAR	Clears received data.
LOCAL	Used to switch from REMOTE mode to LOCAL mode
JOG SPEED	Changes the speed of movement as activated by jog keys. (Auto / Low / Middle / High)
JOG UNIT	Changes the unit of movement as activated by jog keys. (1.0 mm / 0.1 mm) (1/16 inch / 1/160 inch)
<<	Used to move to the previous menu screen
>>	Used to move to the next menu screen
POSITION SELECT	Sets the final head position.
PLOT ORIGIN	Moves to the drawing origin.
CUT AREA	Moves to the specified point at the edge of the cut area.

Cable Connections



- Turn off the power (☞ P.3-51) before connecting the vacuum signal line cable, RS-232C interface cable, cable for optional accessories, or Ethernet cable. Otherwise, there is a risk of electric shock or damage to the machine.

Connecting the Power Cable

After connecting interface cables, connect the power cable. Plug the power cable into an outlet with the following power supply specifications.

- Voltage: 200–240 V AC $\pm 10\%$, single phase
- Frequency: 50/60 Hz

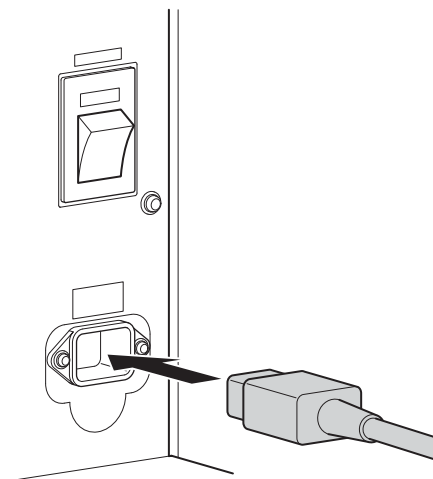

- **Be sure to ground the machine**
- It is extremely dangerous to use the machine without grounding it, due to the risk of electric shock or machine damage.

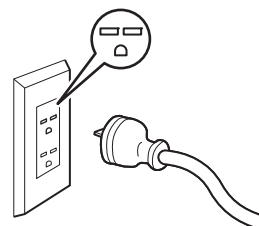

Connecting Interface Cables

The unit is equipped with an RS-232C compliant interface and a LAN port. Use the RS-232C interface cable recommended by Mimaki or a suitable cable for your computer. The communication conditions must be set to suit the interface used. For details, refer to “Setting Computer Connection Conditions” (☞ P.4-46).

- **Turn off the plotter and computer before connecting cables.**

Connect the vacuum cable.

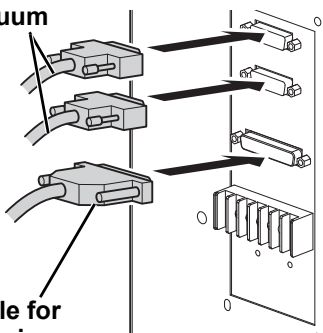

Connect the cable for optional accessories.

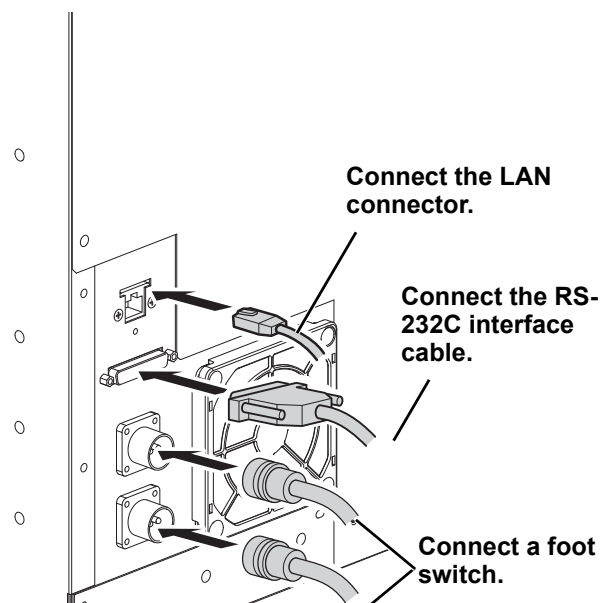

Connect the LAN connector.

Connect the RS-232C interface cable.

Connect a foot switch.

Local/Remote Mode

Each press of [LOCAL] [REMOTE] on the operating panel switches between local and remote mode.

Local Mode and Corresponding Display

In local mode, you can move the head, set various machine functions, and receive data from the computer. All keys are available in local mode.

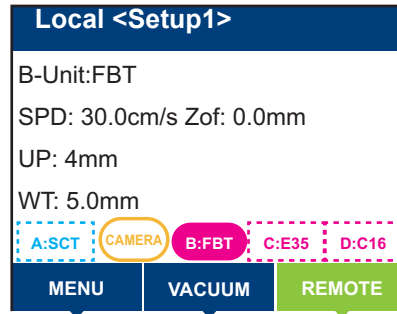

Remote Mode and Corresponding Display

Remote mode enables cutting or drawing of the data received.

The display shows the cutting (or drawing) conditions and the amount of data received. The amount of data indicated decreases with each cut (or stroke).

The [END/POWER] key, [VACUUM], and [LOCAL] on the operating panel are enabled.

In remote mode, the following seven screens are displayed.

Swivel cutter selected (standard unit)

This is the remote mode screen when A-Unit is selected in [Tool Select] on the local mode screen and the swivel cutter (SCT) is selected as the tool.

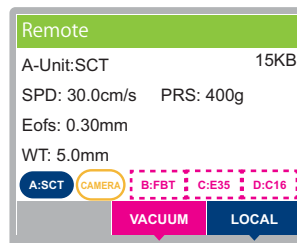

SPD: Cutting speed
PRS: Cutting pressure
Eofs: Offset value
WT: Work thickness

Pen selected (standard unit)

This is the remote screen when A-Unit is selected in [Tool Select] on the local mode screen and the pen is selected as the tool.

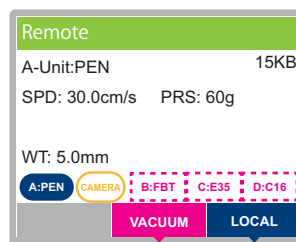

SPD: Cutting speed
PRS: Cutting pressure
WT: Work thickness

Emergency Stop

In emergencies, the machine can be stopped on an emergency basis.
Emergency switches are located at four positions at the front and rear of the machine.

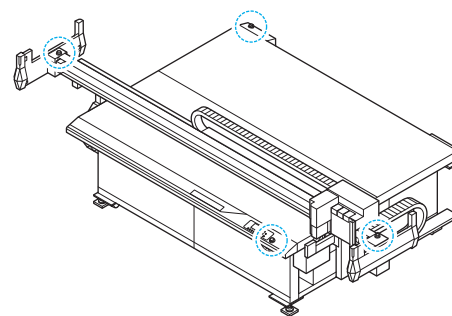

Using Emergency Stop

- 1** Press an emergency switch.
 - The machine stops operating.

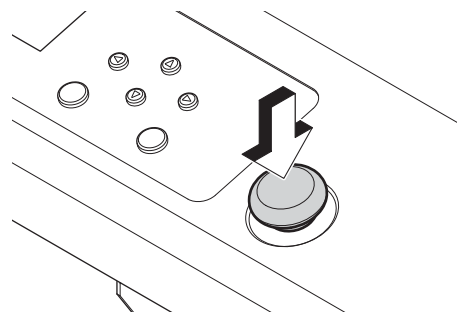

Resetting an Emergency Stop

- 1** Turn the emergency switch clockwise to unlock it.

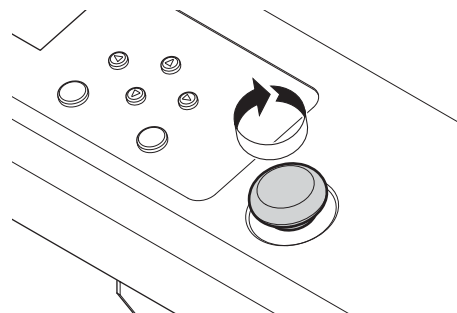

- 2** Press the [ENTER] key.
 - The machine starts up.

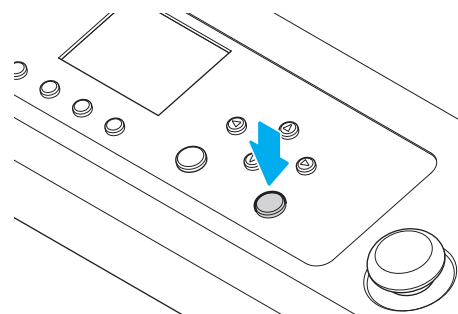



- If any unit from B to D remains lowered after resetting, a confirmation message is displayed. Confirm that there will be no problem if the tool is raised, and then press the [ENTER] key.
- If a V-cut cutter is in a work, remove the V-cut holder.

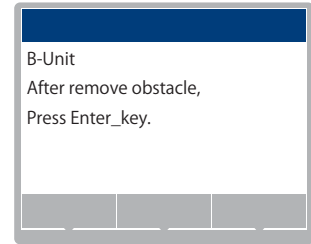

Removing the V-cut holder following an emergency stop

Use the following procedure to restore operation in cases where an emergency stop was made with the cutter blade left inserted into the work.

1

Hold the V-cut holder still with your hand and turn the V-cut tool knob on the top of the bearing holder counterclockwise as viewed from above.

- Turn to the position of the unlock mark.

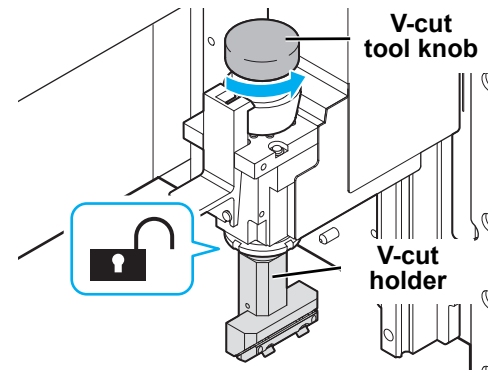

● When using the V45 tool TYPE-S or VAS tool TYPE-S

- Pull out and turn the index plunger knob to unlock, then turn the V-cut tool knob.

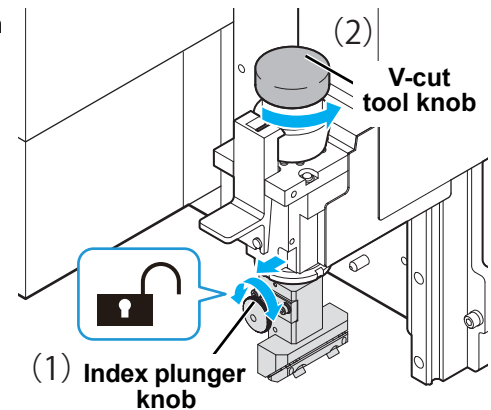

2

After turning until unlocked, press the [ENTER] key to start the resetting operation.

- After the Z-axis rises and stops, remove the unlocked V-cut holder.
- Press the [ENTER] key again to move the head to the final position.

Preparing the Cutting Panel

Attaching the Work Guides

Attach the work guides as guides to keep works straight.
Attach guides to suit the work size, at the position desired.

Important!

- Make sure the work guides are securely attached in the holes on the cutting panel surface. The head may come into contact with loose work guides that are not attached securely when the machine is turned on, which may cause damage.
- These are only guides for setting up works straight. Perfect accuracy is not ensured.



- Be sure to check the orientation of the work guides when attaching them. (Attach so that the indented side faces the inside of the table.)
Attaching the work guides incorrectly may damage the tool.

- Attach the work guides in the holes at the following positions on the cutting panel surface.
- Attach the work guides along the edges of the mat.
- Attach the work guides at two locations near the origin (fixed) and at the far end on the long side (for movement) to suit the media used. Guiding as much as possible toward the outer side will make it easier to minimize tilting.

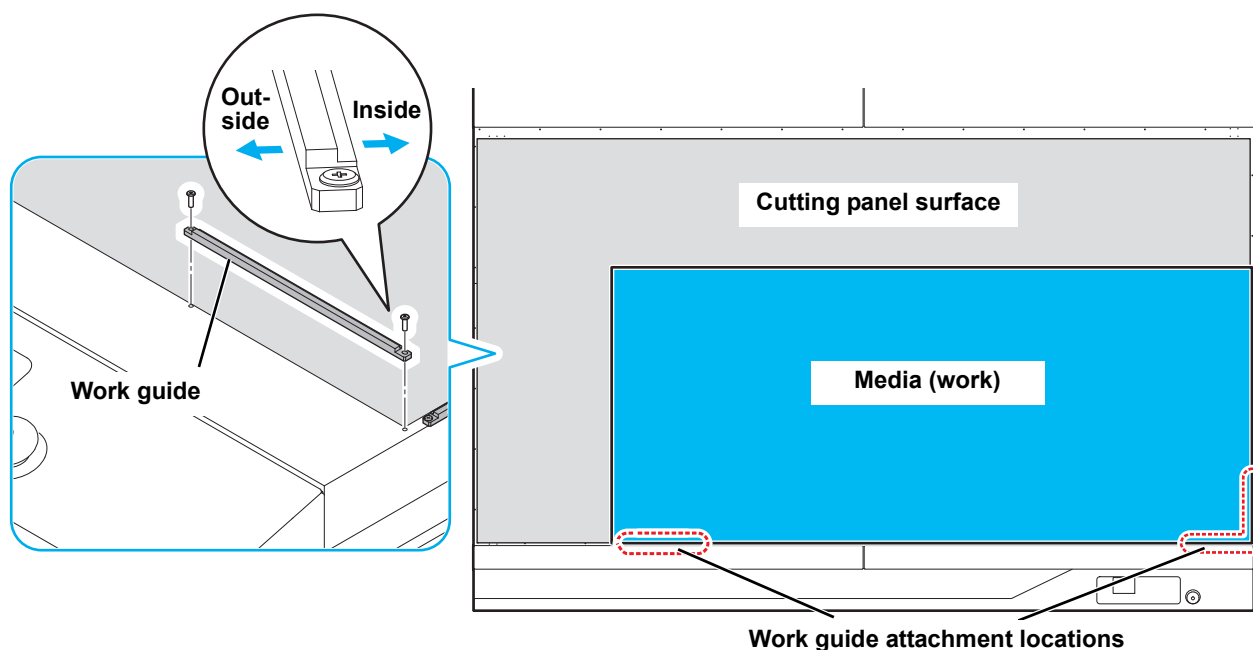

Flat Blade Tool selected (TUT)

This is the remote screen when the unit selection is B, C, or D in [Tool Select] on the local mode screen and the Flat Blade Tool (FBT) is selected as the tool.

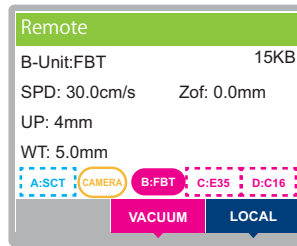

SPD: Cutting speed
Zof: Z origin offset value
UP: Up height
WT: Work thickness

Electric reciprocating tool selected (TUT)

This is the remote screen when the unit selection is B or C in [Tool Select] on the local mode screen and the electric reciprocating tool (E12, E35, E60) is selected as the tool.

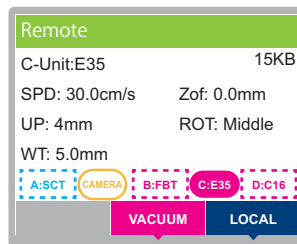

SPD: Cutting speed
Zof: Z origin offset value
UP: Up height
ROT: Reciprocating vibration level
WT: Work thickness

Crease tool selected (TUT-15, TUT-30)

This is the remote screen when the unit selection is B, C, or D in [Tool Select] on the local mode screen and the crease tool (C16, C26, C60, C6A) is selected as the tool.

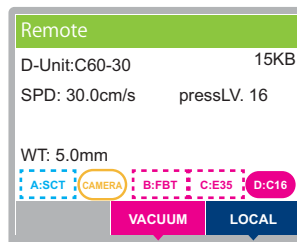

For pressure mode levels 1 to 31
Pressure level:
 With TUT-15 mounted: OFF, LV. 1 to 16
 With TUT-30 mounted: OFF, LV. 16 to 31
WT: Work height

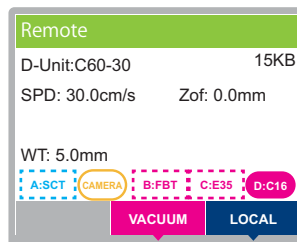

With pressure mode off
SPD: Cutting speed
Zof: Z origin offset value

V-cut tool selected (TUT)

This is the remote screen when the unit selection is B, C, or D in [Tool Select] on the local mode screen and the V-cut tool (V45, VAS) is selected as the tool.

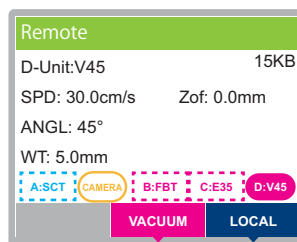

SPD: Cutting speed
Zof: Z origin offset value
ANGL: Edge angle
WT: Work thickness

Hint!

- Because V-cut up height cannot be changed from 5 mm, this information is not shown.

Router unit select (R10)

This is the remote screen when D-Unit is selected in [Tool Select] on the local mode screen and the router unit (R10) is selected as the tool.

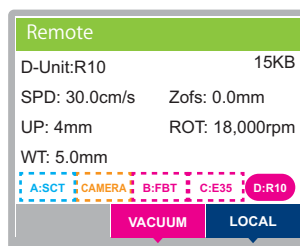

SPD: Cutting speed
Zof: Z origin offset value
UP: Up height
ROT: Rpm
WT: Work thickness

Matching the Plotter Specifications

The machine uses MGL-3C commands.

Set the commands of the software that is connected to the machine to MGL-3C.



- The machine only uses MGL-3C commands. Commands cannot be changed from the plotter.

Setting Automatic Head Retraction

Set the final head position after cutting (or drawing) the data from the computer is finished.

Item	Setting value
(1) Off	No automatic retraction.
(2) Lower right	Retract to the lower right.
(3) Lower left	Retract to the lower left.
(4) Upper right	Retract to the upper right.
(5) Upper left	Retract to the upper left.
(6) Middle right	Retract to the middle right (not applicable for CFX-2513).
(7) Middle left	Retract to the middle left (not applicable for CFX-2513).
(8) Drawing origin	Retract to the drawing origin.

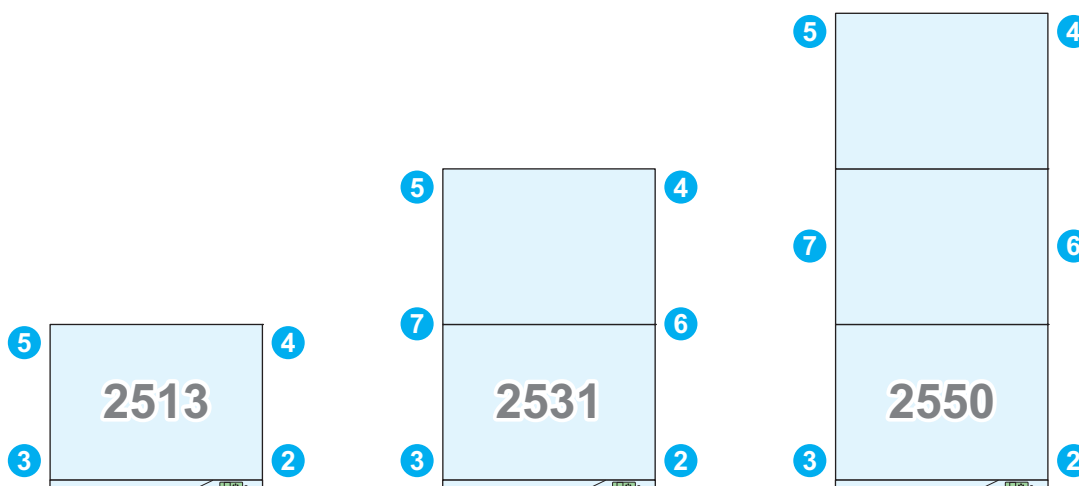
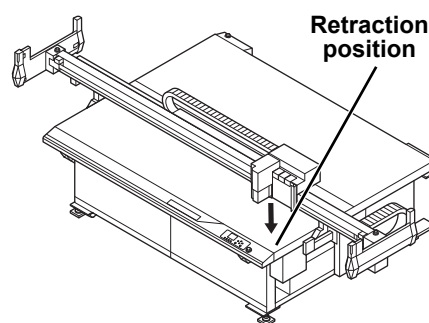

Important!

- Retract to the middle in toggle mode.
- Middle right and middle left are only available on CFX-2531 and CFX-2550 models (not on CFX-2513 models).

1

On the local mode screen, press [MENU].

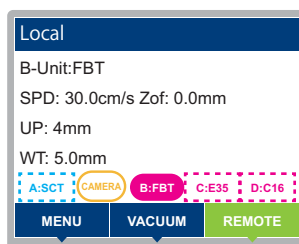

2

Press \triangle ∇ to select [Setup] > [Draw] > [Auto View], then press the [ENTER] key.

3

Press \triangle ∇ to select the retraction position, then press the [ENTER] key.

- Setting values: OFF, lower right, lower left, upper right, upper left, middle right, middle left, drawing origin

4

To exit, press the [END/POWER] key several times to return to the local mode screen.

Setting the Vacuum

This section explains how to adjust the settings when the optional vacuum unit is connected.

What is a vacuum unit?

The vacuum unit is an optional attachment that connects to the cutting panel. When attached, the vacuum unit enables the following:

- The work on the cutting panel can be suctioned to prevent movement during cutting.
- Suction area selection valves can be used, enabling suction according to the size of the work.

Restrictions regarding the vacuum unit

- Do not operate the vacuum when all suction area range selection valves are closed. Doing so may result in failure.
- For the OPT-01035 7.5 KW Vacuum Unit (200 V) and the OPT-01036 7.5 KW Vacuum Unit (400 V), the soundproof box's cooling fan operates for ten minutes after vacuum operation stops. Ensure that the cooling fan operates normally during vacuum operation. If the cooling fan does not operate during vacuum operation, discontinue use immediately. There may be a malfunction in the equipment.
- The intake noise from the vacuum unit's relief valve increases as the suction area for work on the cutting panel increases.
- The operating noise level may increase during use, exceeding 70 dB near the vacuum unit. We recommend using hearing protection, such as earplugs or earmuffs, in reverberant environments or during prolonged use.
- When using the OPT-01037 Toggle Unit, you may hear a high-pitched airflow noise when you stop the vacuum operation. This is normal.



- This product is a filter designed exclusively for intake applications.
- The filter element is made of paper and is flammable; therefore, it must not be used with substances that reach high temperatures capable of igniting it.
- Do not use with water or oil.
- When the differential pressure reaches approximately 1.0 kPa, clean the element with soapy water, dry it thoroughly, and then reinstall it.

Enabling/Disabling Auto Vacuum Off

Set vacuum auto-off operation.

Item	Setting value
Enable *1	If the automatic head retraction setting is enabled, the vacuum automatically turns off after the head is retracted.
Disable	The vacuum remains on even after head retraction.

*1. The vacuum is not automatically turned off when automatic head retraction is set to off.



- When a work is replaced during continuous cutting of register marks, the vacuum is automatically turned off regardless of the automatic head retraction setting.

1

On the local mode screen, press [MENU].

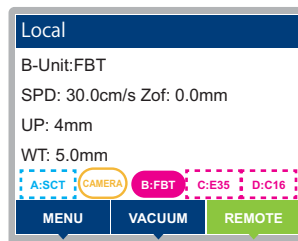

2

Press \uparrow \downarrow to select [Setup] > [Draw] > [Vacuum Auto-Off], then press the [ENTER] key.

3

Press ▲ ▼ to select a setting option, then press the [ENTER] key.

- Setting values: Disable, Enable
- To exit without saving, press the [END/POWER] key.

4

To exit, press the [END/POWER] key several times to return to the local mode screen.

Interlock between Remote Key and Vacuum

The vacuum can be turned on/off automatically using the remote key. (The remote key is [REMOTE] when in local mode and [LOCAL] when in remote mode.)

Cutting without the vacuum on may cause works to rise and interfere with cutting.

This can be prevented by setting [Vacuum Auto-On] to [Enable].

Item	Setting value
Enable	Vacuum is automatically turned on when remote mode is selected with the remote key. Note that vacuum is turned off when the remote key is used to switch to local mode.
Disable	The vacuum key on the operating panel turns the vacuum on/off.

Hint!

- Has no effect in continuous or toggle mode (remains on or off).

1

On the local mode screen, press [MENU].

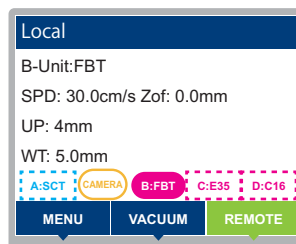

2

Press ▲ ▼ to select [Setup] > [Draw] > [Vacuum Auto-On], then press the [ENTER] key.

3

Press ▲ ▼ to select [Setup], then press the [ENTER] key.

- Setting values: Disable, Enable
- To exit without saving, press the [END/POWER] key.

4

To exit, press the [END/POWER] key several times to return to the local mode screen.

Hint!

- If the Vacuum Auto ON is enabled, when the vacuum is switched from OFF to ON, there will be a time delay before the workpiece is automatically adsorbed. In the time delay state, the following display will appear (firmware version 1.8.0 or later).

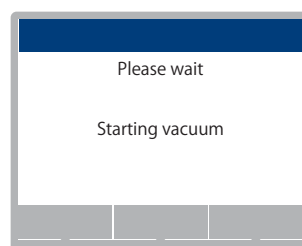

When shifting from local mode to remote mode

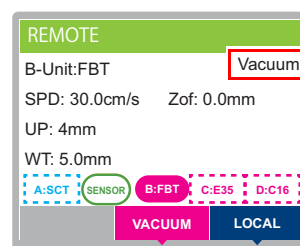

In remote mode "Vacuum" will be displayed on the right side

Setting the Camera Unit

Setting instructions for a connected camera unit (optional) are as follows.

Camera Unit Overview

This optional unit enables mounting of a camera on the head. The following operations are available when the unit is linked to the camera app (OBSCURAS). Also refer to the OBSCURAS instruction manual.

- Detection of freely placeable register marks
- Work edge detection
- Detection of register marks even for works that are significantly tilted

Register mark limitations

Register marks with the following specifications can be detected by the camera unit.

- Length of each side: 10 mm
- Line width: 1 mm

Camera Settings

Set up the camera in the optional settings of the machine.

- 1** On the local mode screen, select [MENU].

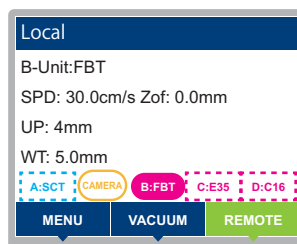

- 2** Select [Machine Setup] > [TP Detect Setup] > [Mark Detect], then press the [ENTER] key.

- 3** Press \triangle ∇ to select [Camera], then press the [ENTER] key.

Adjusting Camera Image Quality

If peripheral brightness or work coloring prevent detection, the camera image quality must be adjusted. For details of image quality adjustment, refer to the camera application (OBSCURAS) function guide.

Chapter 2

Tools



About this chapter

This chapter describes how to mount tools.

Using a Combination of Units	2-2	Mounting a Reciprocating Cutter	2-17
Combining Stations and Units	2-2	Mounting a Creasing Tool	2-22
Unit and Tool Combinations	2-2	Mounting a V-cut Tool	2-26
Mounting Tools (Standard Unit)	2-4	Mounting the Work Holder	2-34
Pen	2-4		
Mounting a Pen Adapter	2-5		
Swivel cutter (optional)	2-8		
Mounting Tools (Tangential Unit)	2-10		
Tangential Unit (TUT) Structure	2-10		
Mounting the Tangential Unit	2-11		
Mounting the Flat Blade Tool	2-14		

Using a Combination of Units

This chapter describes the procedures for attaching units (standard and tangential) to each of the stations A to D, and for setting the tools.

Combining Stations and Units

The tangential units can be mounted on stations B, C, or D only. However, if electric reciprocating tools E12, E35, or E60 are mounted on a tangential unit, the unit can be mounted only on station B or C.

The router unit can be mounted only on station D.

Hint!

- The standard unit cannot be removed. It can be started regardless of whether or not a holder is mounted.
- Stations B, C, and D can be started even when no unit is installed. (A cover should be fitted to stations that are not used.)

Unit and Tool Combinations

The following tools can be used in combination with the machine's units.

Unit		Mountable tools	
Standard unit [1]		Swivel cutter holder, ballpoint pen holder, commercially available pen holder (☞ P.2-4)	
Tangential unit [3] (optional)	TUT-15, TUT-30	Flat Blade Tool FBT [5]	Flat cutter blade holder [10] T04, T06 (☞ P.2-14)
		Electric reciprocating tool E12, E35, E60 [6]	Reciprocating cutter blade holder [11] S06, M06, L06, S10 (☞ P.2-17)
		Creasing tool C16, C26, C60 [7]	Crease roller tool [12] C16, C26, C60 (☞ P.2-22)
	TUT-30 only	V-cut tool V45, VAS [8]	V-cut holder [13] V45, VAS (☞ P.2-26)
Router unit [4] (optional)		End mill [15]	R10 (☞ P.2-32)

Station

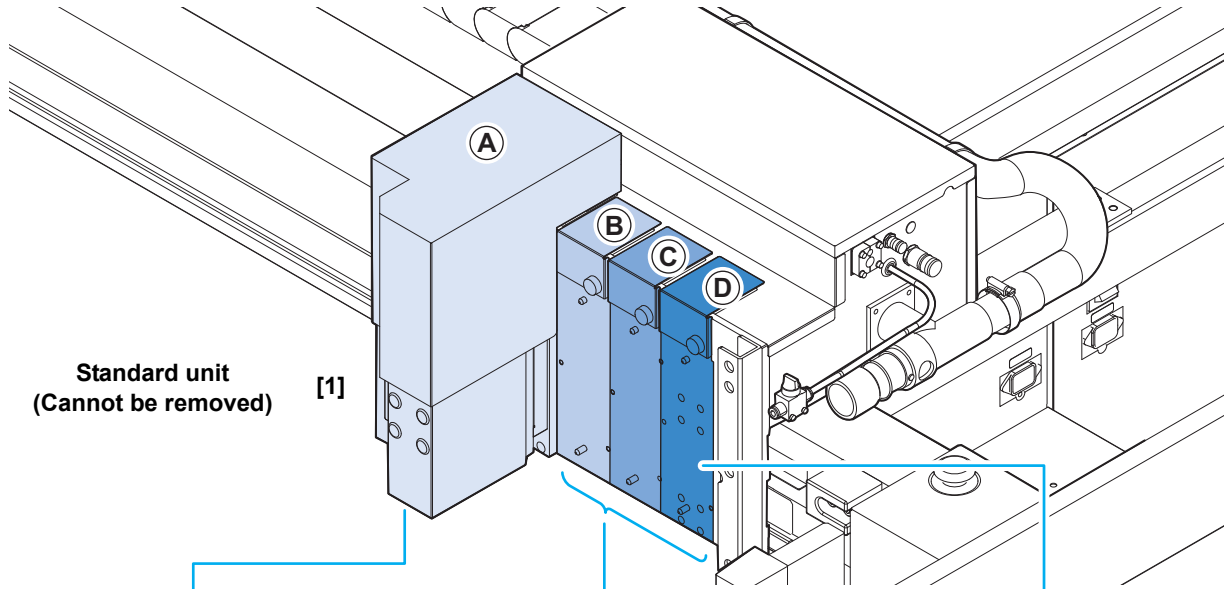

Units

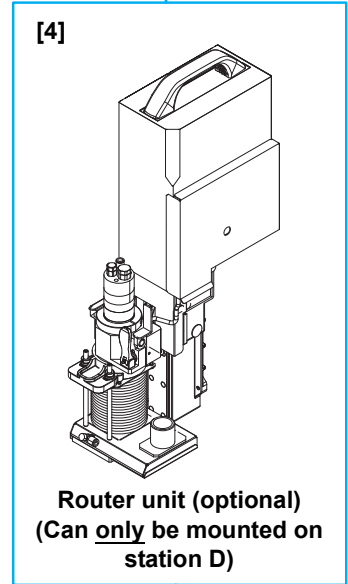
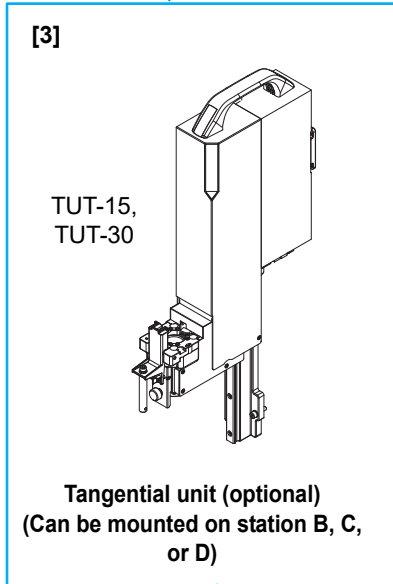
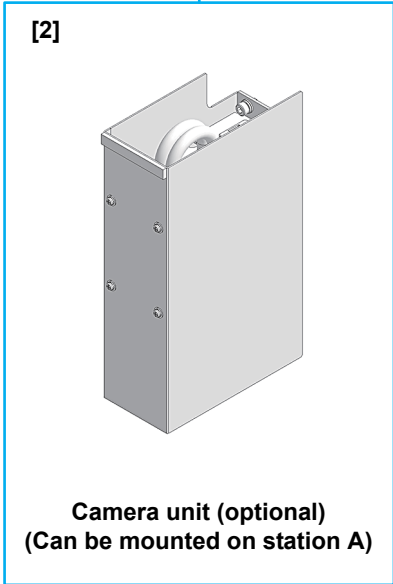

Tools

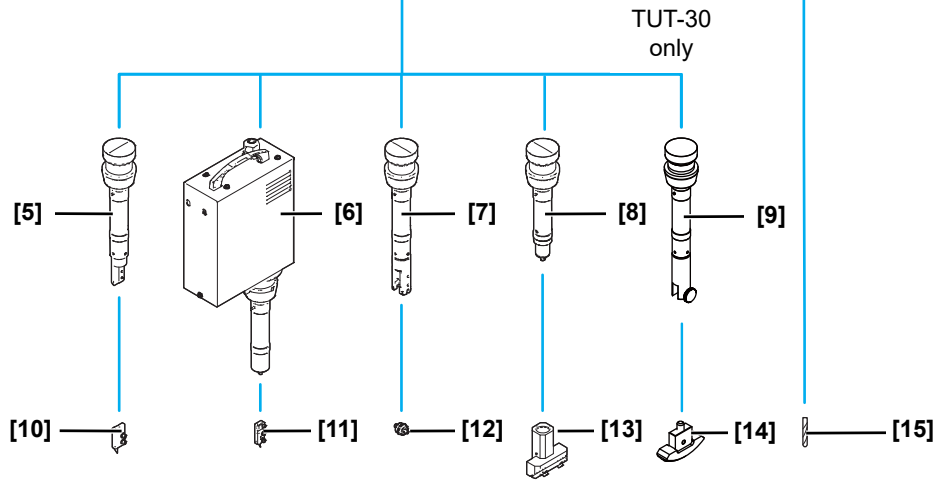





Mounting Tools (Standard Unit)

The following tools can be mounted on the standard unit

- Pen
- Swivel cutter (supplied)

Pen adapter

- This should always be left on.
- Adjustment must be repeated in the following sequence if the pen adapter has been removed or mounted. This is essential if positional and dimensional accuracy is required.

- (1)  P.4-9 “Aligning the Pointer Position”
- (2)  P.5-17 “Aligning the Register Mark Detection Position”
- (3)  P.3-28 “Offset adjustment (tangential unit)”
 P.6-11 “Adjusting the Router Unit R10”



- Failure to perform offset adjustment may result in issues such as offset between the tool cutting positions and offset of the cutting position when using register marks.

Pen

Mounting a pen on the ballpoint pen holder

Mount the standard included pen as follows.

1

Fit the spring over the pen tip.

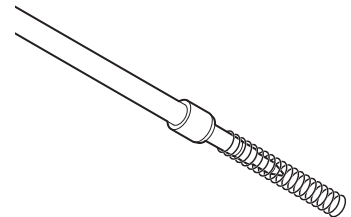

2

Mount on the pen holder while pressing the spring into the cap.

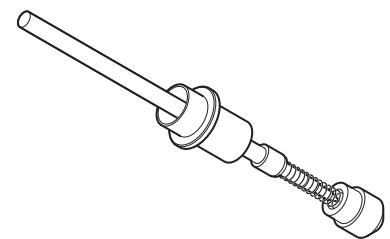

3

With the pen holder mounted on the pen adapter, mount on station A ( P.2-5)

Mounting a Pen Adapter

- 1** Insert the ballpoint pen holder or swivel cutter holder in pen adapter A.

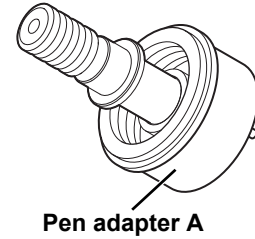

- 2** Attach pen adapter B.

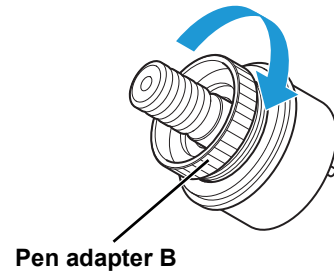

- 3** Turn the station A screw to loosen the holder for the pen holder.

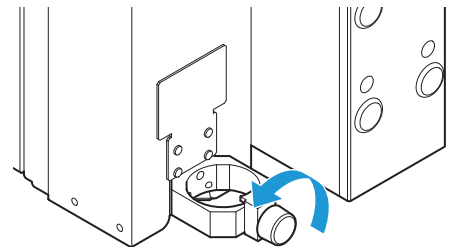

- 4** Load the pen adapter and turn the screw to tighten.

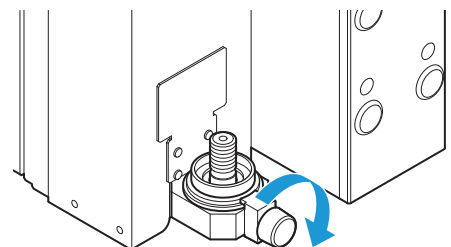

Attaching caps

Caps are used to protect works and tables.
Remove caps in the following cases.

- When using pens
- When using swivel cutters
- During tool adjustment

Important!

- Be sure to leave caps attached when thickness measurement is automatically detected.

1

Attach the cap from below.

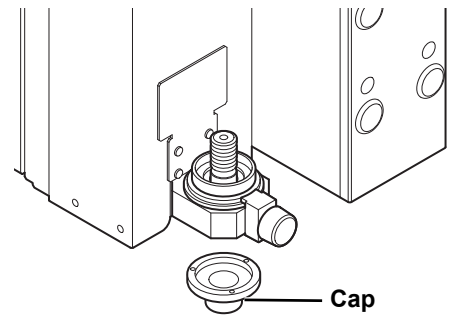

Mounting a pen on the universal pen adapter (optional)

The universal pen adapter (optional) enables use of commercially available pens.

1

Remove the cap of the pen to mount.

2

Loosen the lock nut (silver part),
then extend universal pen adapter.

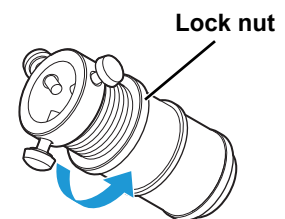

3

Loosen the set screws (3) and insert the pen.

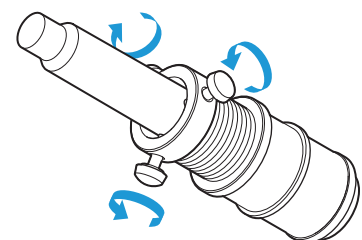

4 Tighten each set screw the same amount, so that the pen is held in place with the tip centered.

- Adjust the pen as needed to center it, as viewed from directly above.

Important!

- Use the guide inside the adapter for pens with a small diameter (12 mm or less).

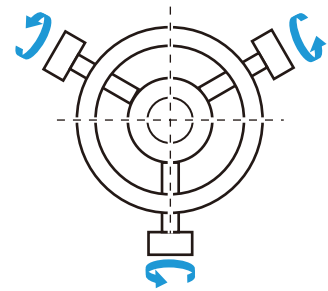
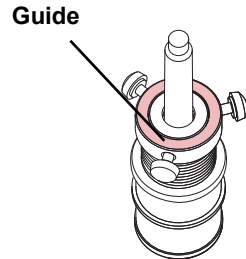

5 Retract the universal pen adapter, so that the tip is extended until it comes into contact with the lid.

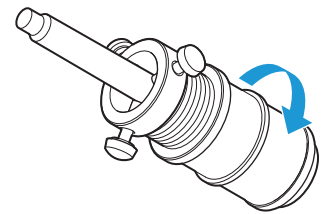

6 Tighten the lock nut.

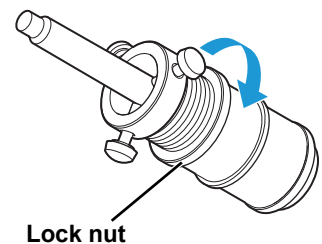

7 Mount the universal pen adapter on station A.

- See step 3 and later in P.2-5 “Mounting a Pen Adapter”.

Important!

- Remove the cap before use. Also refer to the following instructions. (P.2-6)

Marker pens compatible with CFX series

For details, see “Marker Pens Compatible with the CFX Series” (P.9-31).

Swivel cutter (optional)



- Handle with care to avoid injury from the blade. For safety, use the included tweezers.
- The swivel cutter is suited to cutting where the adhesive sheet or base paper needs to be left behind. If the cutter blade is inserted as far as the felt surface, there is a risk of it being left inside the felt, resulting in injury or damage.
- It is recommended that the flat blade tool (FBT) is used for cutting where the cutter blade is inserted as far as the felt surface.

Attaching swivel cutter blades

Attach the swivel cutter blade to the swivel cutter holder.

1

Remove the cap from the cutter holder.

- Turn in the direction indicated by the arrow in the picture.

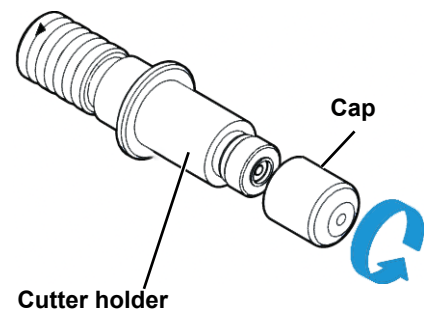

2

Insert the cutter into the cutter holder.

- Use tweezers to insert the blade.

Important!

- Be sure to load the blade with the blade tip pointing up.

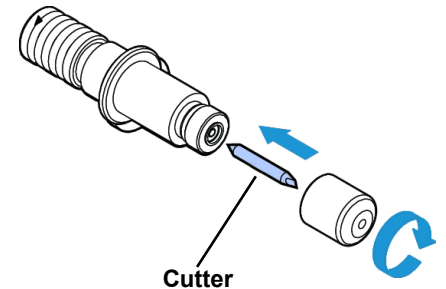
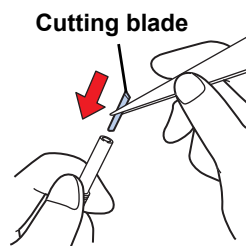

3

Fix the cap by turning in the direction indicated by the arrow in the picture.

4

Turn the adjusting knob to adjust the amount of protrusion of the blade tip.

- Turn the adjusting knob in the direction indicated by the arrow in the picture to have the blade protrude. (0.5 mm per turn)

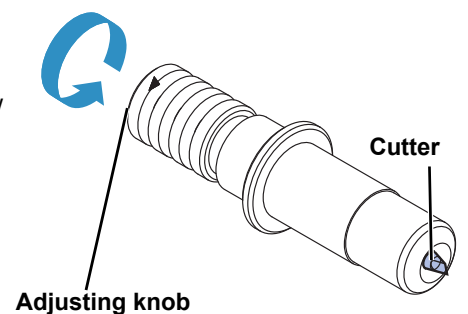

5

Attach the swivel cutter holder to the pen adapter and mount it on the standard unit
(☞ P.2-5 “Mounting a Pen Adapter”).

Mounting Tools (Tangential Unit)

Tangential Unit (TUT) Structure

Any of the following tools can be mounted on the tangential unit.

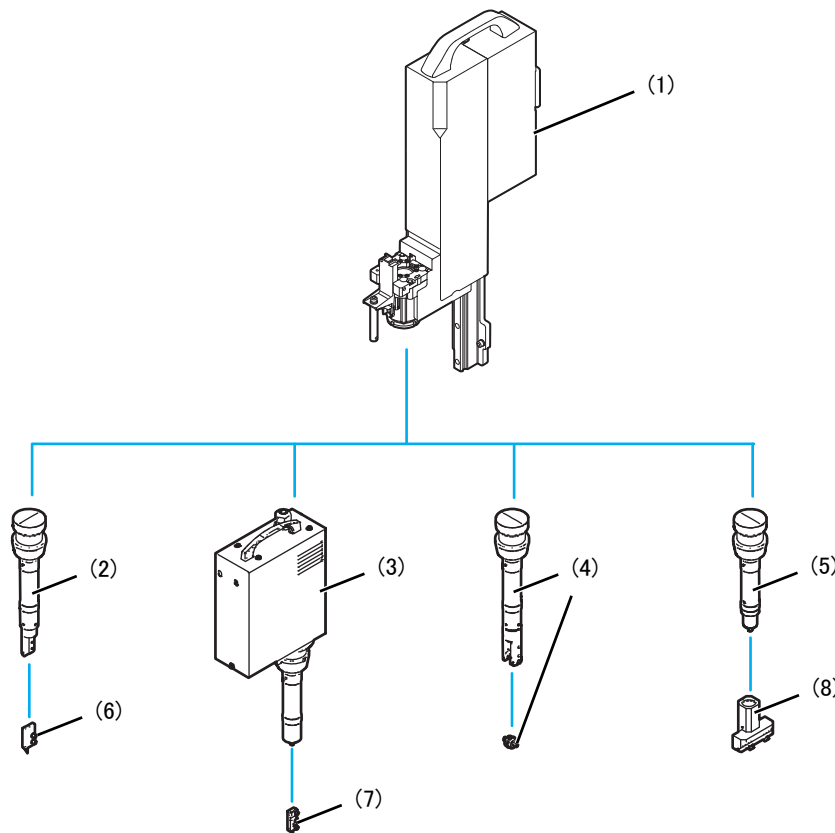

No.	Name	Abbreviation or type	Reference page
(1)	Tangential unit	TUT-15, TUT-30	P.2-11
(2)	Flat Blade Tool	FBT	P.2-16
(3)	Electric reciprocating tool	E12, E35, E60	P.2-19
(4)	Creasing tool	C16, C26, C60, C6A	P.2-22
(5)	V-cut tool	V45, VAS	P.2-27
(6)	Flat cutter blade holder	T4, T6	P.2-14
(7)	Reciprocating cutter blade holder	S06, M06, L06, S10	P.2-17
(8)	V-cut cutter holder	V45, VAS	P.2-26

Mounting the Tangential Unit

For blades to mount, use only genuine Mimaki tools. Use of other tools may result in inaccurate cutting edge detection.

Tool	Corresponding blade length
FBT	24.8 to 45 mm
E12	28 to 65.2 mm
E35	28 to 65.2 mm
E60	28 to 65.2 mm



- For safety, be sure to turn off the power to the main unit before this work. (Do not attempt mounting or removal when the power is on. Failure to observe these instructions may damage the equipment.)
- For safety, be sure to remove the tool before removing or attaching the unit. (There is a risk of injury if the blade is left on.)
- Wait at least 30 seconds before turning the machine on again after it has been turned off. Failure to observe these instructions may result in malfunctioning.

Attaching the tangential unit

1

Turn the main unit off.

2

Remove the station terminal cover mounting the tangential unit.

- Remove the retaining screw.

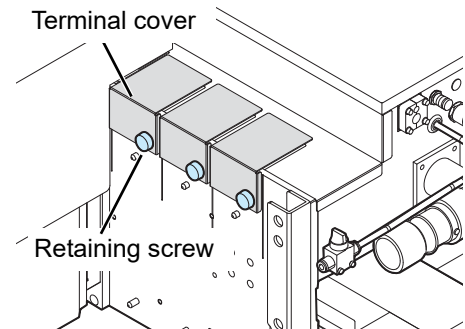

3

Using the head groove as a guide, insert the tangential unit into the station from above and slowly lower it.

- Fit the positioning pin (1) on the rear of the tangential unit into the station.
- Fit the positioning pins (2) on the station into the grooves of the tangential unit.

Important!

- Make sure the mounting surface is free of dust and other debris.

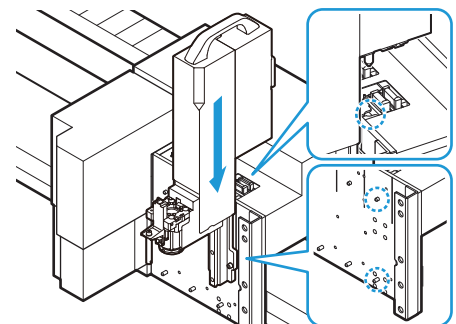

4

Using the included hex wrench, turn the two screws on the unit to secure in place.

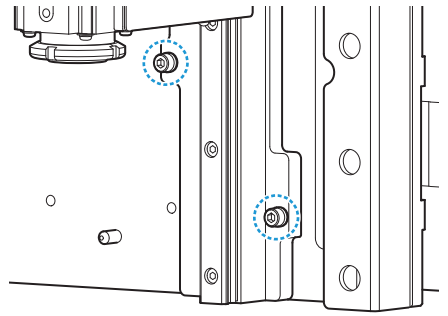

Removing the tangential unit

1 Turn the main unit off.

2 Using the included hex wrench, turn the two screws on the unit to remove it.

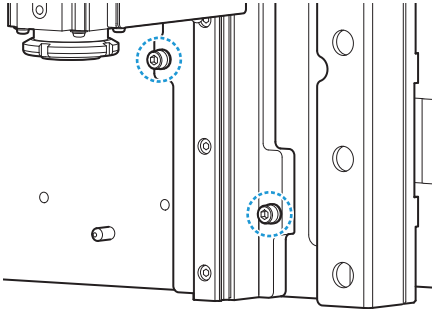

3 Pull the tangential unit off the station while supporting with both hands, and slowly lift it up.

- The tangential unit is heavy. Be sure to support it with both hands and lift it up slowly.



- Take great care when performing this task to ensure that the unit does not come into contact with the A unit or adjacent tangential units resulting in accidents.

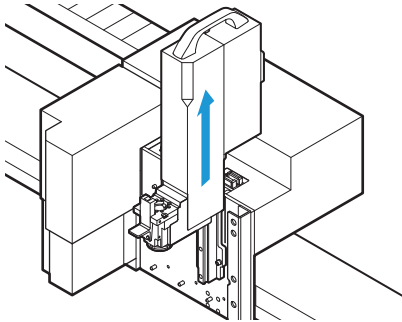

4 Mount the terminal cover to the station from which the tangential unit has been removed.

- Secure with the retaining screw.

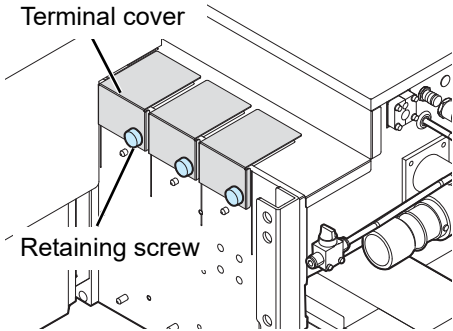

Mounting the Flat Blade Tool



- Always wear safety gloves when handling tools and cutter blades. Failure to observe these instructions may result in injury from the blade.
- Be sure to repeat cutting edge detection (☞ P.3-14) if the blade has been replaced.



- Mount the blade so that it faces in the direction shown in the figure below.

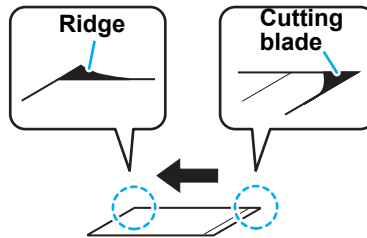

- When mounting an NT high-speed steel blade, use the hand lapper provided to grind down the cutting edge and ridge. Grinding down the ridge allows it to be properly mounted in the holder. Grinding (rounding) the cutting edge increases durability. Grind down the cutting edge approximately 5 to 20 times, checking the amount ground.

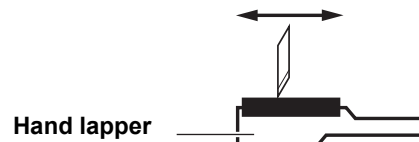

Mounting the flat blade



- A flat blade holder is required in order to mount a flat blade.
- Flat blade holders are available for T4 and T6 types. (For T4, the holder has a groove as viewed from the side. If the wrong holder is used, the blade will not stay in place and cutting will be unstable.)

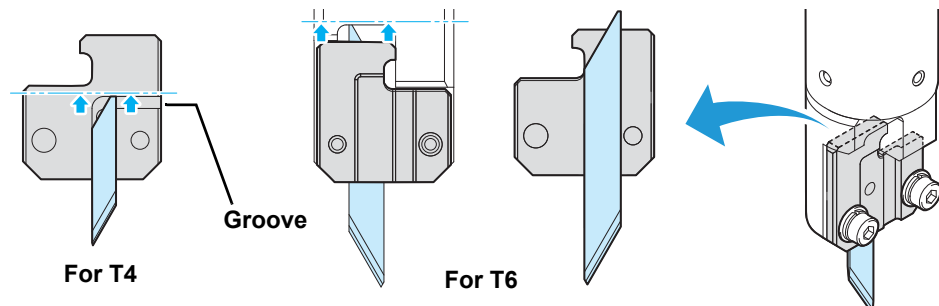

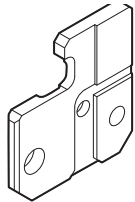
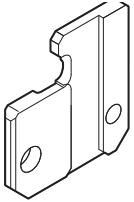
Form		
holder	Blade holder T4	Blade holder T6
Blades used	SPB-0030 blade for low-pressure PVC sheet/SPB-0047 titanium-coated blade 30°/SPB-0050 titanium-coated blade 30°/SPB-0045 carbide blade 30°/SPB-0043 high-speed steel blade 30°/SPB-0080 carbide blade 30° DLC/SPB-0093 carbide blade 45° (25L)	Carbide design blade 30°/Joint sheet blade

1

Using the included hex wrench (2.5 mm), temporarily tighten the set screws to secure the flat blade holder to the Flat Blade Tool.

- Select a holder that suits the blade you will mount.

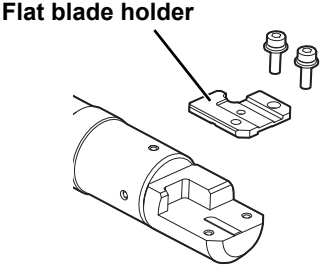

2

Insert the flat cutter blade into the flat cutter blade holder until it rests firmly against it.

- For safety, use the included tweezers.
- Note the direction of the blade.



Retaining screw

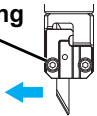

Insert so that the blade edge is facing the left when viewing the flat blade tool as shown in the figure.

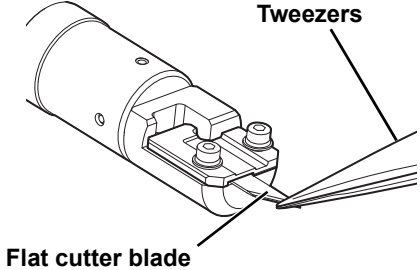

3

Make sure the blade does not ride over the groove.



- Mistakenly tightening the set screws while the blade is riding over the groove may deform the blade.

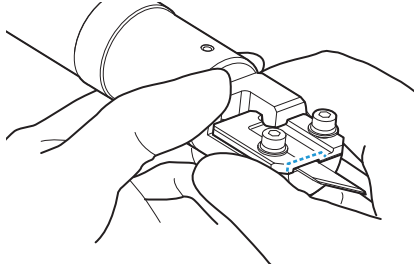

4

Using the supplied hex wrench (2.5 mm), tighten the set screws to secure the blade.



- When replacing the blade, the blade can be removed by loosening only the right-hand screw. There is no need to loosen the left-hand screw. Both screws only need to be removed when replacing the cutter blade retainer.

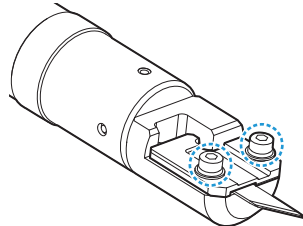

For blade replacement

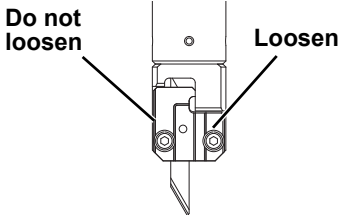

2

Mounting the Flat Blade Tool



- Even when only the cutting blade was replaced, be sure to use [Tool Exchange] to detect the cutting blade (☞ P.3-14). If the procedure is not followed, there is a risk of the cutting depth changing, possibly damaging the cutter blade or equipment, or causing injury.

1

Attach a flat blade to the flat blade holder (☞ P.2-14).

2

Mount the tangential unit on the station (☞ P.2-11).

3

Select [Menu] > [Tool] > [Tool Exchange].

- [Move the head to the Right edge.] is displayed. (This screen does not appear if the head is already at the right end.)

4

Press the [ENTER] key.

- The head moves to the right end.

5

Once the head has stopped, mount the flat blade tool on the tangential unit from above.

- Fit the control pin of the Flat Blade Tool into the groove at the rear of the tangential unit.

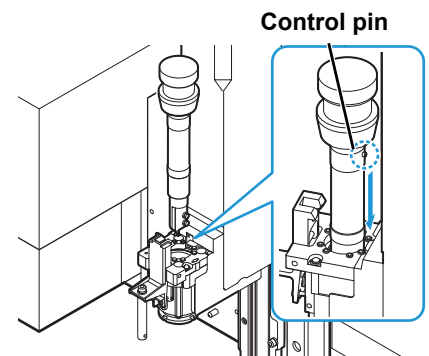

6

Lower the tangential unit tool lock lever and insert the Flat Blade Tool into the opening, all the way down.

- Once it is inserted all the way down, raise the tool lock lever to secure the Flat Blade Tool.

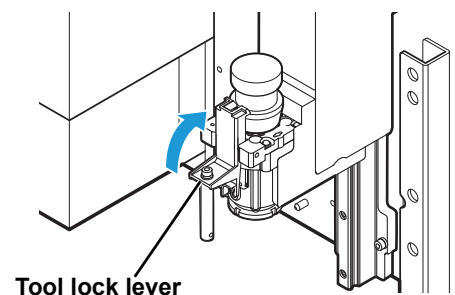

7

Once the tool has been mounted, press the [ENTER] key.

- The resetting operation starts.

8

Perform cutting edge detection (☞ P.3-14).



- Exiting the [Tool Exchange] menu changes all of the tools to cutting edge undetected.

Mounting a Reciprocating Cutter

The reciprocating cutter can be mounted on the B or C station.
For details, see “Combining Stations and Units” on page 2.”



- Always wear safety gloves when handling tools and cutter blades.
Failure to observe these instructions may result in injury from the blade.
- Be sure to repeat cutting edge detection (☞ P.3-14) if the blade has been replaced.

Attaching a reciprocating cutter blade



- A reciprocating cutter holder is required in order to mount a reciprocating cutter.
- The various types of reciprocating cutter holders are distinguished by their shape and the number of indentations on the side. Refer to the table below to select the appropriate holder for the blade used.

Form	 One indentation	 One indentation	 One indentation	 Two indentations
holder	SPA-0343 Reciprocating cutter holder S06	SPA-0344 Reciprocating cutter holder M06	SPA-0345 Reciprocating cutter holder L06	SPA-0346 Reciprocating cutter holder S10
Blades used	SPB-0075 carbide blade 7 × 15 SPB-0064 carbide blade 2°	SPB-0055 20 mm blade SPB-0065 carbide blade 17°	SPB-0077 carbide blade 25 × 5 SPB-0078 carbide blade 25 × 5_DLC	SPB-0094 S10 reciprocating cutter blade carbide 2° × 50 mm
Notes	For 0.6 mm thick blade: One indentation	For 0.6 mm thick blade: One indentation	For 0.6 mm thick blade: One indentation	For 1.0 mm thick blade: Two indentations

1

Using the included hex wrench (2.5 mm), loosen the cutter holder set screws.



- Do not tighten the upper screws until attached to the reciprocating tool. Accidentally tightening may deform or damage the clamp.

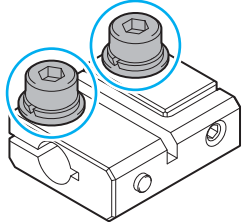

2

Insert the reciprocating cutter blade fully into the cutter holder.

- For safety, use the included tweezers.
- Note the direction of the blade.

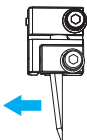

Insert the blade so that it is to the left of the screws.

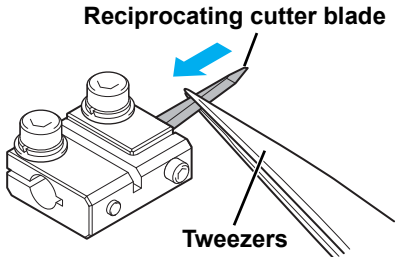

3

Hold the cutter blade with tweezers as you temporarily tighten the screws.

- Temporarily tighten the screws so that only a little pressure is applied to the spring washers of the screws.

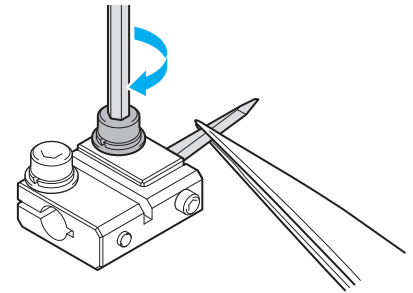

- Do not tighten the upper screws until attached to the reciprocating tool. Accidentally tightening may deform or damage the clamp.

**4**

Tighten the side hex socket set screws (1 mm).

- The side set screw is not included on the M06/L06 holders. This step is performed only when using the S06/S10 holders.
- The cutter blade holder now holds down the blade.

Important!

- Use the hex head screwdriver provided. Using a hex wrench or other tools may damage the blade.

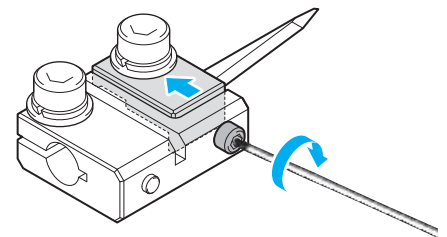
**5**

Fully tighten the screws temporarily tightened in step 3.

Important!

- Make sure the cutter blade holder is not rising up.

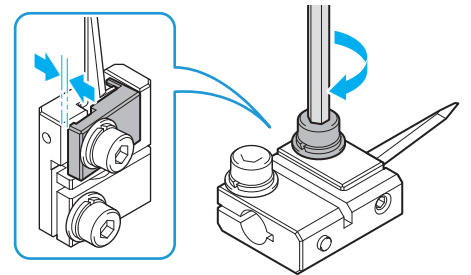
**6**

If the cutter blade holder is rising up, temporarily loosen the side hex socket set screws.

7

Press down on the holder as you tighten the hex socket set screws again, then fully retighten the screws.

- The side set screw is not included on the M06/L06 holders. This step is performed only when using the S06/S10 holders.

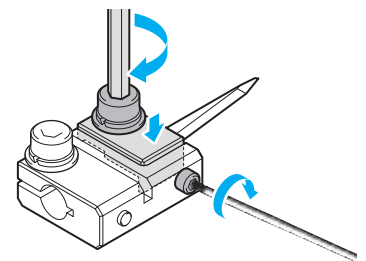

Mounting the Electric Reciprocating Tool and Reciprocating Cutter Holder

Important!

- Lightly apply the grease provided before mounting the electric reciprocating tool. Apply approximately 0.05 g of grease each to the upper and lower parts.

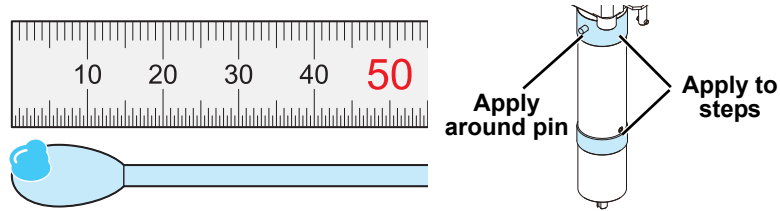

- Approximately once every two weeks, detach the electric reciprocating unit from the TUT, clean the greased areas, then reapply grease.



- Even when only the cutting blade was replaced, be sure to use [Tool Exchange] to detect the cutting blade (P.3-14). If the procedure is not followed, there is a risk of the cutting depth changing, possibly damaging the cutter blade or equipment, or causing injury.

1

Mount the tangential unit on the station (P.2-11).

2

Select [Menu] > [Tool] > [Tool Exchange].

- [Move the head to the Right edge.] is displayed. (This screen does not appear if the head is already at the right end.)

3

Press the [ENTER] key.

- The head moves to the right end.

4

Once the head has stopped, mount the electric reciprocating tool on the tangential unit from above.

- Fit the positioning pins of the electric reciprocating tool into the groove of the tangential unit.

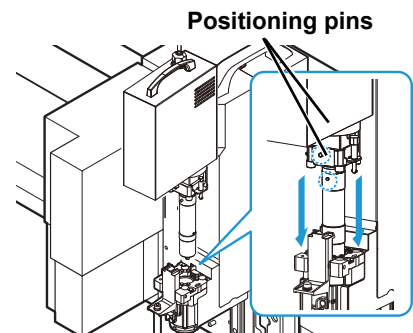

5

Lower the tangential unit tool lock lever and insert the electric reciprocating tool into the opening, all the way down.

- Once it is inserted all the way down, raise the tool lock lever to secure the electric reciprocating tool.
- Press down and turn the stopper pins on the side of both ends 90° to secure.
- If this procedure is difficult due to the closeness of the stopper pins to the other units, insert the hex head screwdriver into the upper holes on the stopper pins.

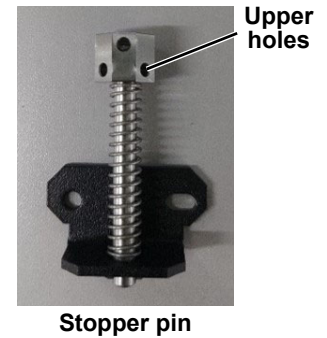
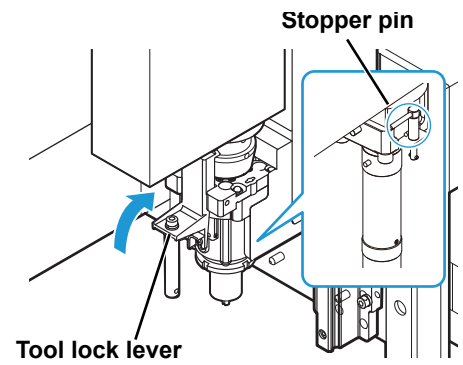
**6**

Connect the electric reciprocating tool connector cable to the tangential unit.

- Turn the connector cable lock to secure.

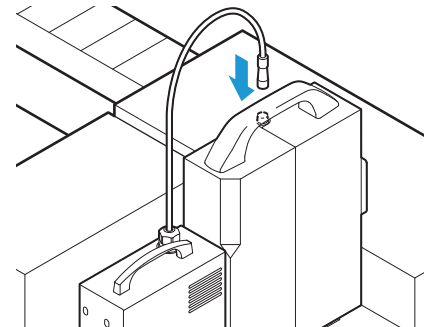
**7**

Attach the reciprocating cutter blade to reciprocating cutter holder (☞ P.2-17).

8

Mount the reciprocating cutter holder, aligning it with the groove on the end of the electric reciprocating tool.

- For safety, use the included tweezers.
- Note the direction of the blade.

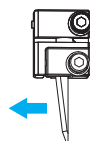

Insert the blade so that it is to the left of the screws.

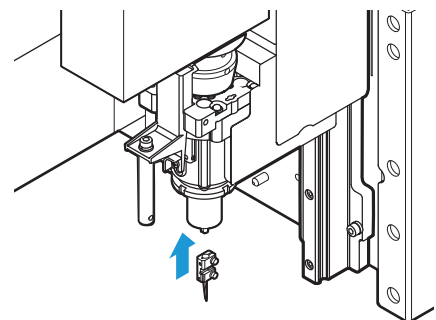

-
- 9** Using the supplied hex wrench, tighten the set screw to secure the reciprocating cutter holder.

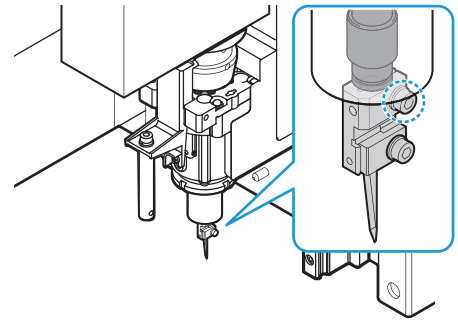

-
- 10** Once the tool has been mounted, press the [ENTER] key.
- The resetting operation starts.

-
- 11** Perform cutting edge detection (☞ P.3-14).

Important!

- Exiting the [Tool Exchange] menu changes all of the tools to cutting edge undetected.
-

Mounting a Creasing Tool

Refer to the table below for the initial setting conditions when using the creasing tool.



- If creasing is performed with an entry depth from the work surface significantly exceeding the recommended value, the creasing roller may become embedded in the media, detach from the tool holder, and damage the equipment or result in injury.
- In FW v3.0.0 or later, if an entry depth from the media surface becomes exceeded during creasing, the Z-down position limit will activate and temporarily pause creasing.

Creasing tool : Entry depth affecting the Z-down position limit	
Tool	Entry depth from the media surface[mm]
C16	1.9 or later
C26	6.9 or later
C60	23.9 or later
C6A	7.0 or later

- If the Z-down position limit is exceeded, Data Clear and cut condition review are strongly recommended, though resuming creasing is also possible. (☞ P.2-25)
- Please be careful that the tip of a boat-shaped tool may become hot under high-load cutting conditions for a long time.





- The table below shows recommended cutting conditions, but results may vary significantly depending on the operating environment and media condition. Set cutting conditions while confirming actual creasing results.
- For information on how to set creasing for each flute direction, refer to the following details in “Chapter 5 Helpful Tips” in the “FineCut Reference Guide”.
 - Cut objects by color
 - Cut objects by layer
 - Specify the output sequence and tools by color/layer
 - Set the output conditions by color/layer

Media	Thickness	Recommended tool	Position control				Pressure control		
			Speed [cm/s]	Flutes	Height from mat [mm]	Insert depth from media surface [mm]	Speed [cm/s]	Flutes	Pressure [Lv]
E flute	1.5 mm	C16	30	Parallel	0.8	0.7	-	-	-
			30	Perpendicular	0.5	1	-	-	-
B flute	3 mm		30	Parallel	2	1	-	-	-
			30	Perpendicular	1.4	1.6	-	-	-
A flute	5 mm	C26	30	Parallel	3.7	1.3	-	-	-
			30	Perpendicular	3	2	-	-	-
AB flute	8 mm	C60	30	Parallel	5	3	-	-	-
			30	Perpendicular	4.1	3.9	-	-	-
AA flute	10 mm		30	Parallel	6.5	3.5	30	Parallel	11
			30	Perpendicular	4.5	5.5	30	Perpendicular	13
Corrugated plastic	5 mm	C26	30	Parallel	2	3	-	-	-
			30	Perpendicular	0.5	4.5	-	-	-
AAA flute	15 mm	C6A	30	Parallel	11.2	3.8	-	-	-
			30	Perpendicular	9	6	-	-	-

Mounting a Creasing Tool

The combinations for each roller and roller tool are fixed. Use the same size items.

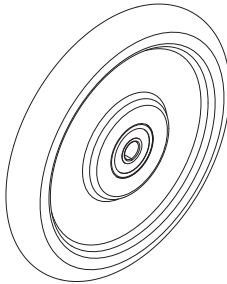
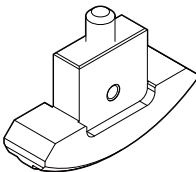
Roller			
	SPB-0098 creasing roller 16-CN SPB-0099 creasing roller 16-DN	SPB-0100 creasing roller 26-T1 SPB-0101 creasing roller 26-CR	SPB-0102 creasing roller 60-UN
Roller tool	OPT-C0261 creasing tool: 16 mm dia. - C16	OPT-C0262 creasing tool: 26 mm dia. - C26	OPT-C0263 creasing tool: 60 mm dia. - C60
Boat-shaped tool			
Tool	OPT-01021 creasing tool: 110mm dia. - C6A		

2

1 Mount the tangential unit on the station (☞ P.2-11).

重要!

- The boat-shaped tool C6A is only available on TUT-30. It cannot be used on TUT-15.

2 Select [Menu] > [Tool] > [Tool Exchange].

- [Move the head to the Right edge.] is displayed. (This screen does not appear if the head is already at the right end.)

3 Press the [ENTER] key.

- The head moves to the right end.

4 Once the head has stopped, mount the crease tool holder on the tangential unit from above.

- Fit the control pin of the crease tool holder into the groove at the rear of the tangential unit.

Important!

- Mount a crease tool holder for the diameter of roller to use.

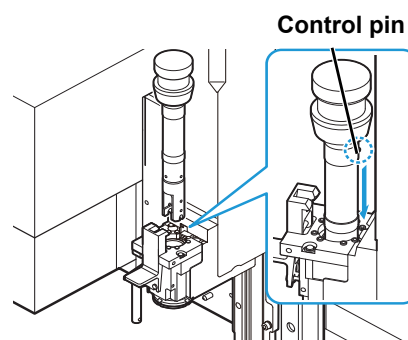

5

Lower the tangential unit tool lock lever and insert the crease tool holder into the opening, all the way down.

- Once it is inserted all the way down, raise the tool lock lever to secure the crease tool holder.

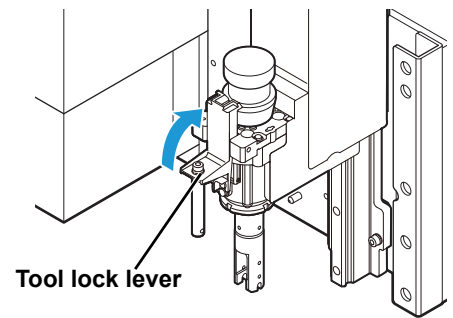
**6**

Attach a roller or a boat-shaped tool to the crease tool holder from below.

- For roller :Push the roller in until it clicks into place.

- For boat-shaped tools: Insert the positioning pin fully into the hole and secure it with a screw.

Hint!

- When securing the boat-shaped tool, use either the included knob screw or the included fixing screw.
- The included T-shaped hex wrench with the machine unit can be used to secure the fixing screw.

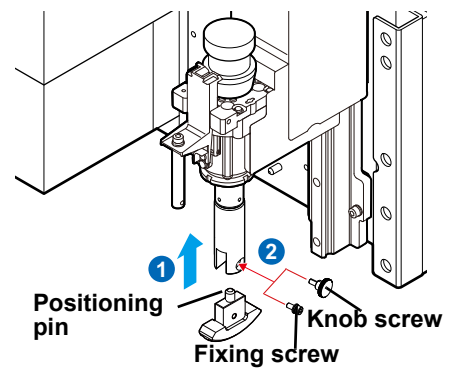
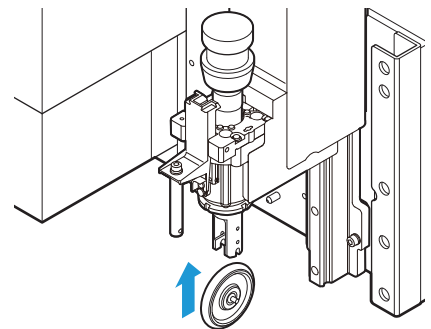
**7**

Once the tool has been mounted, press the [ENTER] key.

- The resetting operation starts.

Hint!

- If the boat-shaped tool C6A is mounted on TUT-15, a warning is displayed and the screen returns to the tool exchange page. Mount C6A on TUT-30 instead or remove the tool.

8

Perform cutting edge detection (☞ P.3-14).

Important!

- Exiting the [Tool Exchange] menu changes all of the tools to cutting edge undetected.

Z-down position limit for creasing tool

In FW v3.0.0 or later, if an entry depth from the media surface becomes exceeded during creasing, the Z-down position limit will activate and temporarily pause creasing.



- Initial settings for each media type and the entry amount at which the Z-down position limit applies for each creasing tool (P.2-22)

1

If the Z-down position limit is exceeded during creasing, the warning “ATTENTION cc6 Z-down Pos limit” is displayed and the guidance screen appears.

- On pages 1-3, press the [FUNC3] key to advance to the next page.

2

On page 4, select the method to resolve the restriction.

- Press the [ENTER] key to clear the data and return to the local mode. Review the operation conditions.
- Press the [END] key to display a confirmation message. The remote mode is displayed, and resume processing.

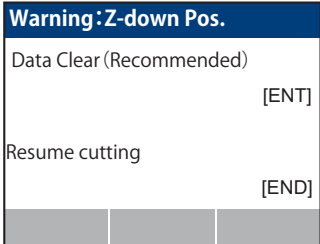

- If creasing is performed with an entry depth from the work surface significantly exceeding the recommended value, the creasing tool may become embedded in the media, detach from the tool holder, and damage the equipment or result in injury.
- When selecting resume processing, continue processing while carefully checking the entry depth of the creasing tool tip into the media and the tool/media condition.



- If resume processing is selected after a restriction occurs, the Z-down position limit is disabled until the currently cutting data is completed.
- However, the Z-down position limit may become enabled multiple times during cutting for data in the following cases:
 - Data that changes between position control and pressure control within a single plotting session
 - Data that uses multiple creasing tools within a single plotting session



- Pressure control may be limited even when the entry depth from the media surface is below the preset value due to media surface conditions or felt mat deflection depending on the specifications. Please check the actual media condition before resume processing.



Mounting a V-cut Tool



- Always wear cut-proof safety gloves when handling tools and cutter blades. Failure to observe these instructions may result in injury from the blade.
- Be sure to repeat cutting edge detection (☞ P.3-14) if the blade has been replaced.
- If the blade angle is changed, be sure to set the edge angle in the cutting conditions to the same value.

Attaching a V-cut blade



- A V-cut holder is required in order to mount a V-cut blade.
- Two types of V-cut holders are available, one for V45 (45°) and one for VAS (variable angle).

1

Align the slots on the V-cut blade with the set screws on the V-cut holder and insert the blade.



- Always wear safety gloves when handling tools and cutter blades. Failure to observe these instructions may result in injury from the blade.

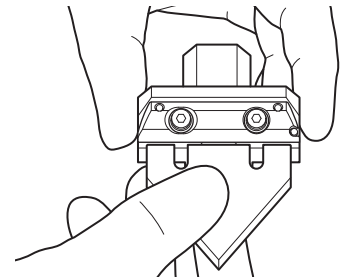

2

Fully insert the V-cut cutter blade.

- Push up against the three locations shown in the figure.

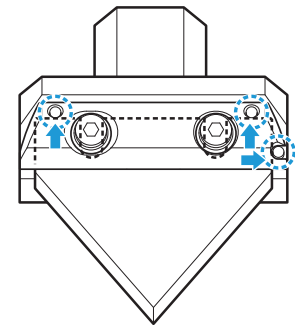

3

Using the supplied hex wrench (3 mm), tighten the set screws to secure the V-cut holder.

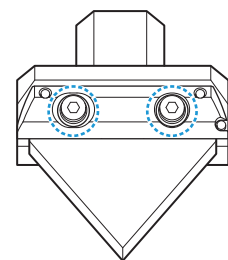

Mounting a V-cut tool



- Even when only the cutting blade was replaced or the VAS tool cutting edge angle was changed, be sure to use [Tool Exchange] to detect the cutting blade (☞ P.3-14). If the procedure is not followed, there is a risk of the cutting depth changing, possibly damaging the cutter blade or equipment, or causing injury.



- A V-cut cap is required in order to mount a V-cut holder.

1

Mount the tangential unit on the station (☞ P.2-11).

2

Attach the V-cut blade to the V-cut blade holder (☞ P.2-26).

3

Attach the V-cut cap to the V-cut tool.

- After attaching, turn the lever to secure the cap.

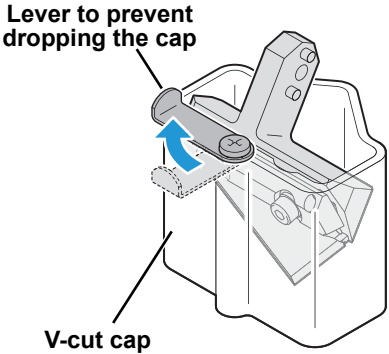

4

Select [Menu] > [Tool] > [Tool Exchange].

- [Move the head to the Right edge.] is displayed. (This screen does not appear if the head is already at the right end.)

5

Press the [ENTER] key.

- The head moves to the right end.

6

Once the head has stopped, mount the V-cut tool on the tangential unit from above.

- Fit the control pin of the V-cut tool into the groove on the tangential unit.



- Attach the V-cut tool for the V-cut holder used.

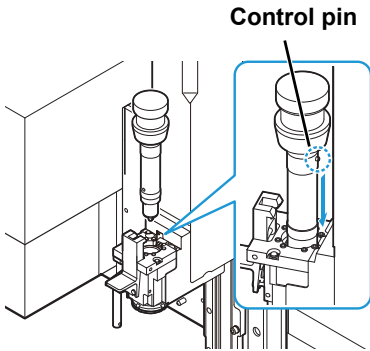

2

7 Lower the tangential unit tool lock lever and insert the V-cut tool into the opening, all the way down.

- Once it is inserted all the way down, raise the tool lock lever to secure the V-cut tool.

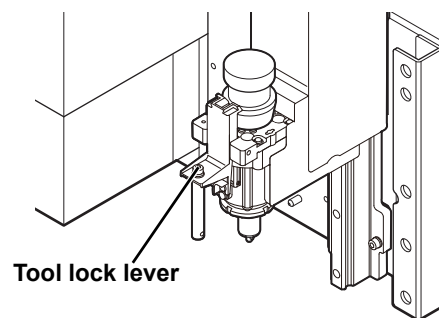

8 Mount the V-cut holder on the V-cut tool from below.

- Insert the V-cut holder into the V-cut tool, with the label aligned.



- Always wear safety gloves when handling tools and cutter blades. Failure to observe these instructions may result in injury from the blade.

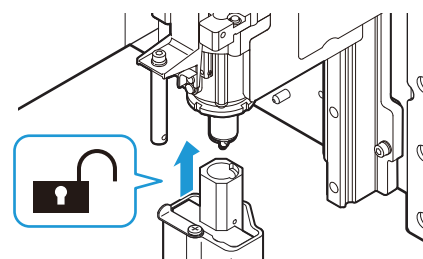

● When using the V45 tool TYPE-S or VAS tool TYPE-S

- Pull out and turn the index plunger knob to unlock, then insert the V-cut holder into the V-cut tool.

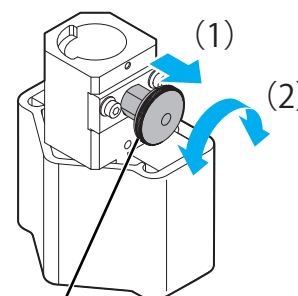

9 Hold the V-cut holder still with your hand and turn the V-cut tool knob on the top of the bearing holder clockwise as viewed from above.

- Turn to the position of the lock mark.
- After attaching, turn the lever to remove the V-cut cap.

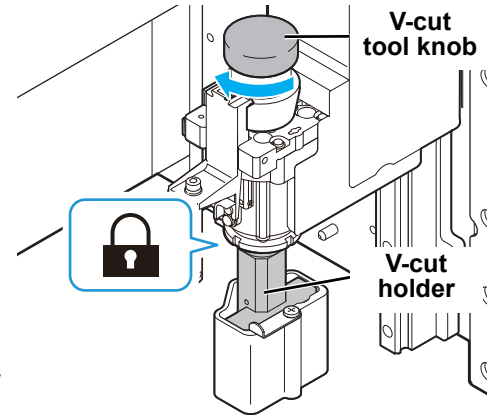

Important!

- Check to confirm that the mark on the V-cut holder is aligned with the lock mark before use. If they are not aligned, the cutter blade or cutting panel may be damaged, or cutting may not be performed correctly.
- Operating without removing the V-cut cap may damage the machine.

● When using the V45 tool TYPE-S or VAS tool TYPE-S

- After inserting the V-cut holder into the V-cut tool, turn the index plunger knob to lock in place.



- When mounting the cutter holder on the tool, turn and press down the index plunger knob, and check to confirm that it is locked before use. If used without locking, the tool may detach when the machine operates, damaging the equipment or causing injury.

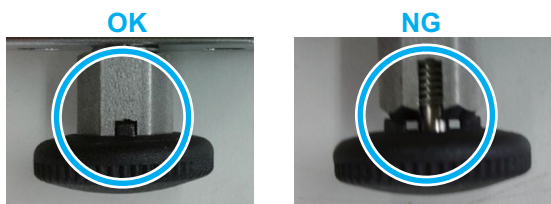
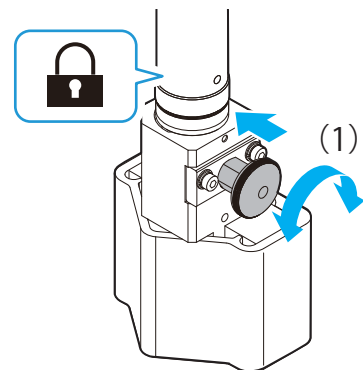

10 After attaching, turn the lever to remove the V-cut cap.

11 Once the tool has been mounted, press the [ENTER] key.

- The resetting operation starts.

12 If the VAS tool is mounted, press ▲ ▼ to select the blade angle, then press the [ENTER] key.

- Settings: 0.0°, 15.0°, 22.5°, 30.0°, 45.0°

13 Perform cutting edge detection (👉 P.3-14).

Important!

- Exiting the [Tool Exchange] menu changes all of the tools to cutting edge undetected.

Removing the V-Cut Holder

1 Select [Menu] > [Tool] > [Tool Exchange].

- [Move the head to the Right edge.] is displayed. (This screen does not appear if the head is already at the right end.)

2 Press the [ENTER] key.

- The head moves to the right end.

3 Once the head has stopped, mount the V-cut cap in the V-cut holder, then turn the lever to secure the cap in place.

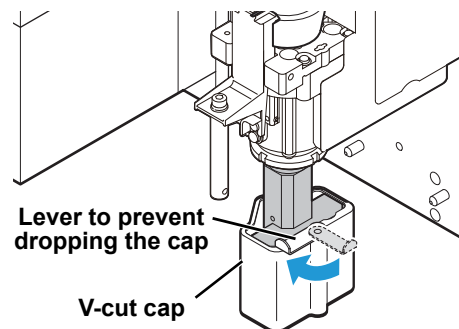

4 Hold the V-cut holder still with your hand and turn the V-cut tool knob on the top of the bearing holder counterclockwise as viewed from above.

- Turn to the position of the unlock mark.



- Always wear safety gloves when handling tools and cutter blades. Failure to observe these instructions may result in injury from the blade.

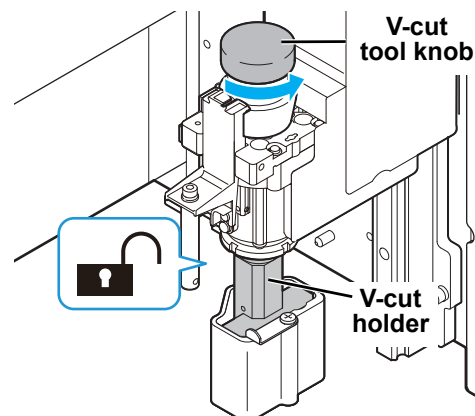

● When using the V45 tool TYPE-S or VAS tool TYPE-S

- Pull out and turn the index plunger knob to unlock, then turn the V-cut tool knob.

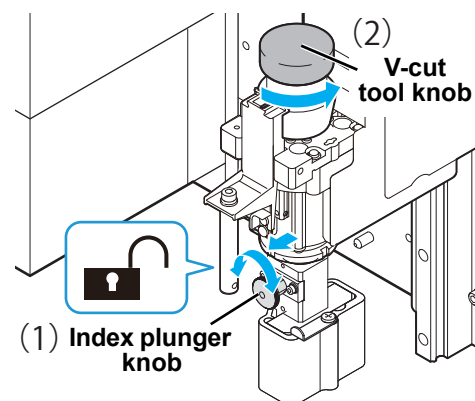

- 5** Pull down the V-cut holder to remove it.

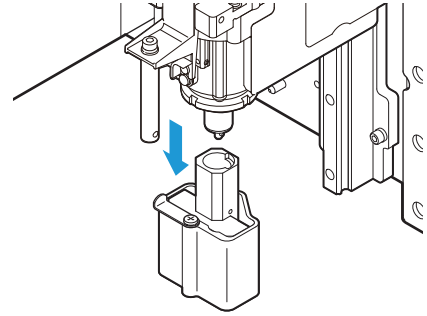

- 6** Lower the tangential unit tool lock lever, and pull up the V-cut tool.

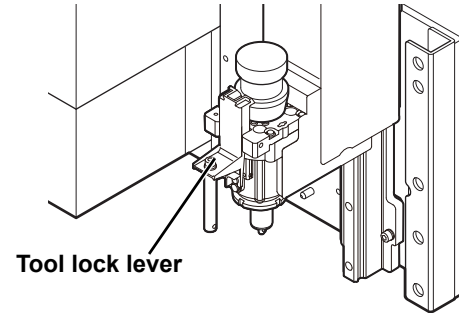

- 7** Once it has been removed, press the [ENTER] key.
• The resetting operation starts.

Changing the blade angle (VAS only)

On VAS (variable angle) V-cut holders, the angle can be changed. Depending on the angle, the mounting position varies as follows.

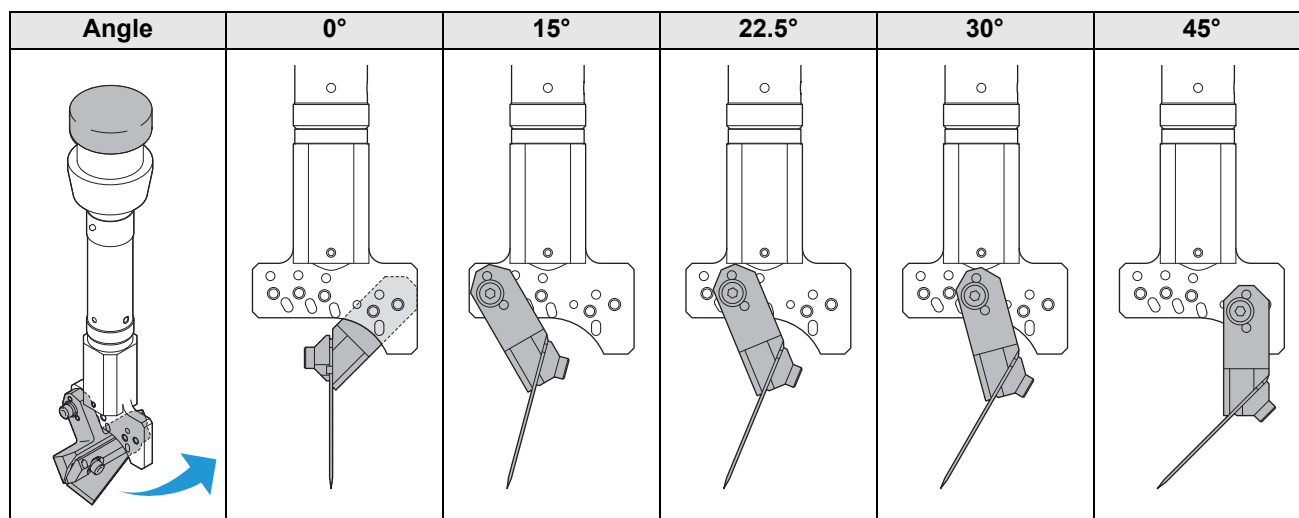

Important!

- When mounting the VAS or changing the blade angle, use the [Tool Exchange] menu as described in Mounting a V-cut Tool (☞ P.2-26), and be sure to set the blade angle and perform blade detection (☞ P.3-14).
- The cutter blade may become misaligned due to the cutting load, so secure it in the direction indicated by the arrow in the figure when clamping the V-cut angle adjustment holder.

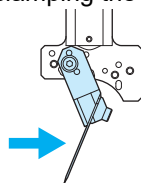

If the blade angle is changed, be sure to set the edge angle in the cutting conditions to the same value. If the blade angle differs from the edge angle in the cutting conditions, the following issues will occur:

- For VAS (0°) and (15°, 22.5°, 30°, 45°), the blade positions differ, so during automatic blade detection, detection may occur outside the ZS sensor, causing failure.
- The blade entry angle is different for V cutting, causing blade breakage or abnormal angles on the V-cut surface.

1

Using the supplied hex wrench (3 mm), loosen the set screw and remove the blade holder.

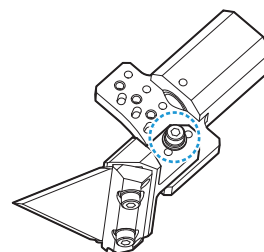

2

Change the blade holder mounting position as needed.

- The angle can be changed by shifting the position left or right.

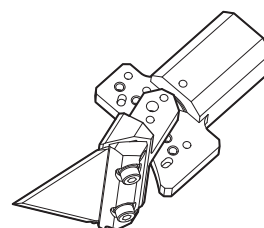

3

Using the supplied hex wrench (3mm), tighten the set screw.

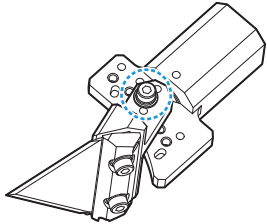

2

Mounting the Work Holder

The work holder prevents the work from rising up after it is cut.

Mount as needed when using the flat blade tool (FBT) or electric reciprocating tool (E12, E35, E60).



- Use the work holder for the following works.
S (provided): FBT, E12, E35 (up to 30 mm)
L (supply item): E60 (up to 54 mm)
Do not use the work holder with soft works (such as sponges). The work holder is designed for use when cutting corrugated cardboard or similar material.
- Use the work holder with the holding surface (indicated by an arrow) fully in contact with the work.
If the holding surface extends beyond the work, such as when you are cutting the edge of a work, the cutter may not be lowered, preventing correct cutting.
- When using work holder L, if there are cutouts or indentations on the work surface, failure to fully raise the tool may result in damage.
- The work holder should be used only when the work lifts up due to cutting, and should not be used in other cases.
- Using with thick work may cause catching on steps generated due to cutting, leading to damage.

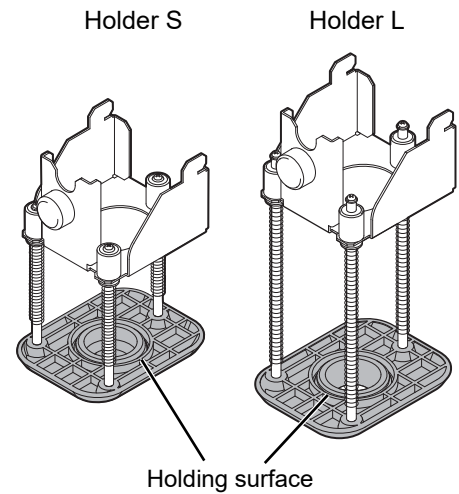

1 Insert the work holder hooks (x2) into the tangential unit slots

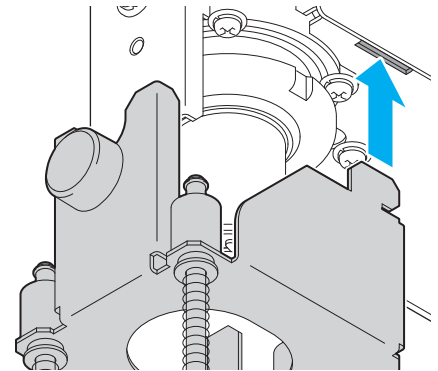

2 Confirm that the hooks are inserted, then tighten the screw.

- Important!**
- When mounting the work holder, hold its mounting surface against the supporter base, so that the work holder is not mounted crooked.

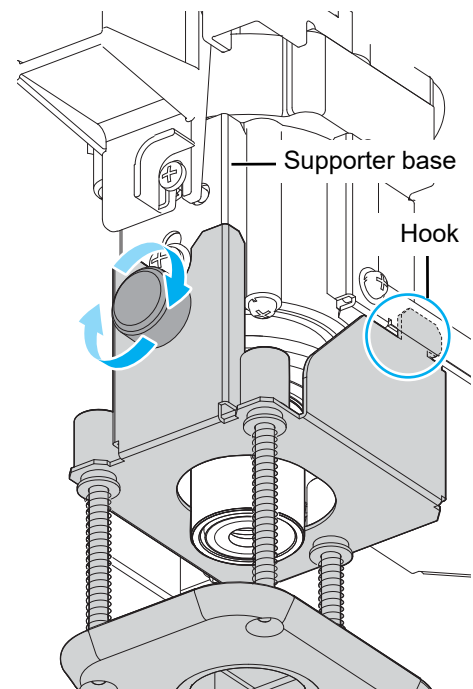
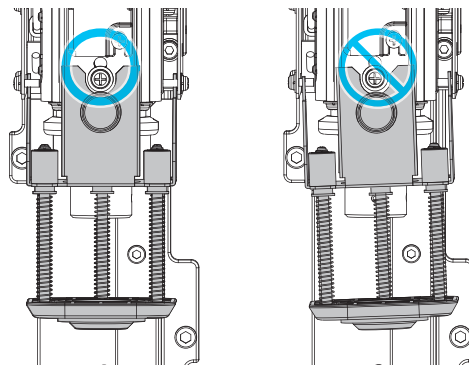

Chapter 3

Basic Operations



About this chapter

This chapter describes the basic operations normally used.

Basic Operation Flow.....	3-2	Circle Θ Correction	3-36
Turning the Power On.....	3-3	Test Cutting.....	3-38
Moving the Head.....	3-4	Checking tool status	3-39
Moving the Head with the [Move to View Pos.] Function	3-4	Checking Status Between Tools (Standard Unit, TUT)	3-42
Moving the Head with the Jog Keys	3-5	Setting the Drawing Origin	3-45
Setting Underlay Thickness	3-6	Moving the Head to the Current Drawing Origin	3-46
Selecting whether or not underlay is used ..	3-6	Cutting or Drawing	3-47
Setting underlay thickness	3-7	Effective Cutting Area	3-47
Securing Works.....	3-9	Cutting or Drawing	3-47
Securing Works with Adhesive Tape	3-9	Interrupting Processing	3-48
Securing Works with Vacuum	3-10	Resuming Processing	3-48
Setting Work Thickness	3-12	Stopping Processing (Data Clear)	3-49
Cutting Edge Detection.....	3-14	Restarting After Safety Sensor Detection ...	3-50
Configuring Tool Settings.....	3-17	Restart procedure after an emergency stop	3-50
Selecting Tools	3-17	Power OFF.....	3-51
Changing Cutting Conditions	3-18		
Setting items	3-19		
Adjusting Tools	3-22		
Adjusting Cutters	3-22		

Basic Operation Flow

The basic operation workflow is as follows.
For details, see the reference page for each step.

1 Turning the Power On See “Turning the Power On” (☞ P.3-3).

2 Moving the Head See “Moving the Head” (☞ P.3-4).

3 Securing Works See “Securing Works” (☞ P.3-9).

4 Securing Works See “Securing Works” (☞ P.3-9).

5 Cutting Edge Detection See “Cutting Edge Detection” (☞ P.3-14).

6 Configuring Tool Settings See “Configuring Tool Settings” (☞ P.3-17).

7 Test Cutting See “Test Cutting” (☞ P.3-38).

8 Setting the Drawing Origin See “Setting the Drawing Origin” (☞ P.3-45).

9 Cutting or Drawing See “Cutting or Drawing” (☞ P.3-47).

10 Power OFF See “Power OFF” (☞ P.3-51).

Turning the Power On

The machine is equipped with two power switches.

Main power supply switch: Located on the right side of the machine's electrical box.

[END/POWER] key (power switch): This switch is normally used to turn the machine on and off.



- Before turning the power on, make sure the cutting panel is free of objects other than the work. When you turn on the power, the head moves to the lower-right retraction point. Head failure may occur if the head strikes an object.
- Make sure the work guides are securely inserted in the holes on the cutting panel surface. The head may come into contact with work guides that are not fully in the holes when the machine is turned on, which may cause damage.
- Wait at least 30 seconds before turning the machine on again after it is turned off. Failure to observe these instructions may result in malfunctioning.

1

Make sure the cutting panel is free of objects.

- Remove any objects from the cutting panel.

2

Turn the main power supply switch on.

- Set the main power supply switch on the right side of the machine to the "I" side.

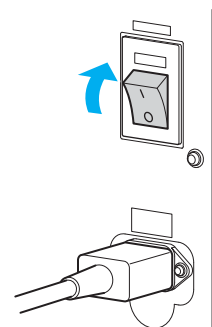

3

Press the [END/POWER] key to turn on power.

- The [ENTER] key is lit (in blue).

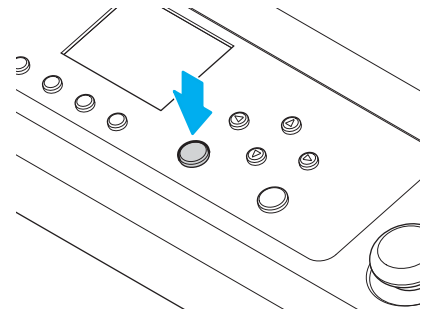

4

Turn on the connected computer.

5

After the confirmation screen at right is displayed, press the [ENTER] key.

- Origin detection begins.
- The head moves to the retraction point.
- The local mode or remote mode screen is then displayed. (The screen displayed will vary depending on the [Startup Mode] setting.)

Hint!

- If [Startup Mode (P.4-43)] is set to remote, the [Work Thickness] screen appears after the origin is detected. (P.3-9)



- If any units from B to D remain lowered after resetting, a confirmation message is displayed. Confirm that there will be no problem if the tool is raised, and then press the [ENTER] key.
- If a V-cut cutter is in a work, remove the V-cut holder. (P.1-17)

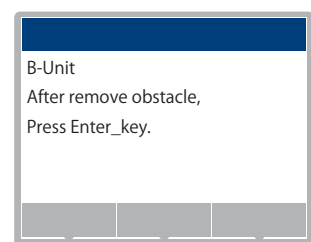
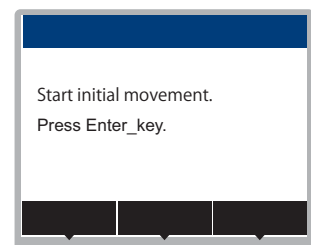

3

Moving the Head

The head can be moved to a more convenient position when securing a work, making a test cut, mounting a tool, or in other situations.

There are two ways to move the head.

- Using the [Move to View Pos.] function
- Moving the Head with the Jog Keys

Moving the Head with the [Move to View Pos.] Function

The head can be moved directly to any corner of the table or to the drawing origin.

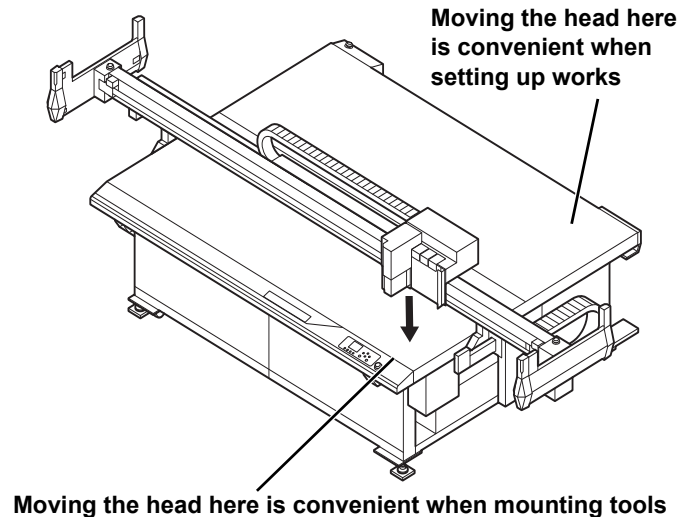

Hint!

- Setting the [Auto View] function (☞ P.1-22) eliminates the need to execute the [Move to View Pos.] function. The head automatically moves to the retraction point after cutting (or drawing) is finished.

1

Press one of the ▲▼◀▶ jog keys once on the local mode screen.

- The [JOG Function Selects] screen is displayed.

2

Press ▲▼ to select [Move to View Pos.], then press the [ENTER] key.

3

Press [POSITION SELECT] and select the retraction position.

- Setting values: Lower right, lower left, upper right, upper left, middle right, middle left, drawing origin (☞ P.1-22)

Important!

- Middle right and middle left are only available on CFX-2531 and CFX-2550 models (not on CFX-2513 models).

4

Press the [ENTER] key.

- The head moves to the specified position.

Moving the Head with the Jog Keys

Use this method when mounting tools, making test cuts, sample cuts, and in other situations. By pressing the jog keys, you can move the head to the exact position needed.

The coordinates indicated are relative to the command origin.

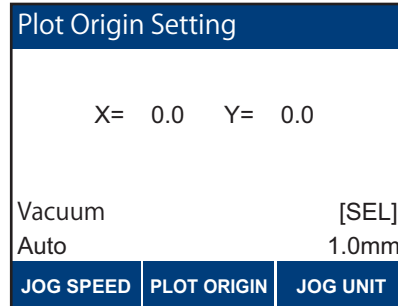

1

Access the local mode screen.

- When in remote mode, press [LOCAL] to enter local mode.

2

Press one of the jog keys once.

- The [JOG Function Selects] screen is displayed.



3

Press the [ENTER] key.

- The head moves over the cutting panel, and the LED pointer is lit.

4

Move the head with the jog keys

- The LED pointer XY coordinates are displayed.
- To move the head diagonally, press two keys at the same time.
Example: To move to the upper-right corner, press   at the same time.

5

To exit, press the [END/POWER] key several times.

Hint!

- If you adjust the jog speed or unit of jog movement, display in the area outlined in red below is updated accordingly. For adjustment instructions, see ( P.4-4).

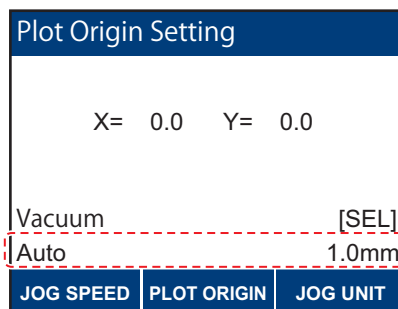

Important!

- Some areas cannot be specified in toggle mode (an error is displayed). The origin cannot be set in the Y-bar retraction area. ( P.4-18)
- Setting the origin in the area at the rear changes the rear area origin.

3

Setting Underlay Thickness

The underlay is a sheet placed underneath the work (between the work and the felt mat) to prevent damage to the felt mat when milling or using other machining processes.

When using underlay, set the underlay thickness using the following procedure.



The set work thickness will be cleared in the following cases. The work thickness should be set again.

- When changing whether or not to use underlay
- When the underlay thickness is changed by manual input
- When the underlay thickness is measured automatically

Selecting whether or not underlay is used

1

Press **▲▼◀▶** on the local mode screen.

- The [JOG Function Selects] screen is displayed.

2

Select [JOG Function Selects] > [Underlay], then press the [ENTER] key.

3

Press **▲▼** to select whether or not underlay is used.

- Setting values: Exist, None
- Default: None

4

Press the [ENTER] key.

- The setting entered is saved.
- After selecting [Exist], pressing the [ENTER] key displays the underlay thickness setting menu.

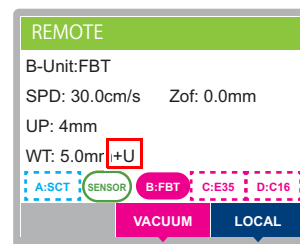
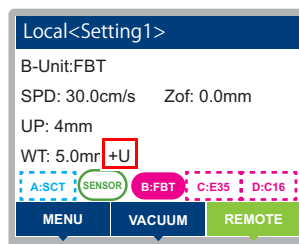

Hint!

- When set with underlay, +U is displayed after the work thickness value in line 4 on the local and remote screens (FW ver. 1.7.1 or later).



Setting underlay thickness

The underlay thickness can be set using either of the following methods.

- Enter the underlay thickness manually  P.3-7 “Enter the underlay thickness manually”
- Measure the underlay thickness automatically  P.3-8 “Measure the underlay thickness automatically”



- When measuring the underlay thickness automatically, be sure to mount the cap on the pen adapter. There is a risk of the pen tip or blade damaging the underlay if the cap is not fitted.

Enter the underlay thickness manually

1

Check (or measure) the underlay thickness.

2



Press     on the local mode screen.

- The [JOG Function Selects] screen is displayed.

3

Select [JOG Function Selects] > [Underlay], then press the [ENTER] key.

4

Press   to select [Exist], then press the [ENTER] key.

- The underlay thickness setting menu is displayed.

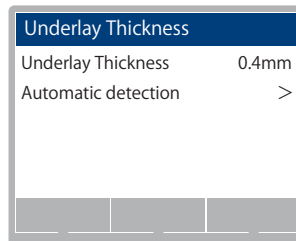



5

Select [Underlay Thickness], then press the [ENTER] key.

6

Press   to enter the underlay thickness, then press the [ENTER] key.

- Pressing the   keys increments or decrements the value by 0.1 mm.

Measure the underlay thickness automatically

1

Make sure pen adapters are capped.

- If the cap is not attached, attach it. (🔧 P.2-6)
-

2



Press     on the local mode screen.

- The [JOG Function Selects] screen is displayed.
-

3

Select [JOG Function Selects] > [Underlay], then press the [ENTER] key.

4

Press   to select [Exist], then press the [ENTER] key.

- The underlay thickness setting menu is displayed.
-

5

Press   to select [Automatic detection], then press the [ENTER] key.

6



Press     to align the LED pointer with the position to measure, then press the [ENTER] key.

- Automatic underlay thickness measurement starts.
 - The measurement results are displayed once measurement is complete.
-

7

Check the measurement results, then press the [ENTER] key.

Hint!

- The underlay thickness measurement results will vary depending on wear and sinking of the felt. The settings can be altered using the   keys before pressing the [ENTER] key for the measurement results.
 - The thickness of the felt mat can be altered. (🔧 P.4-31) This should be reset if the thickness has changed due to wear.
-

Securing Works

There are two ways to secure works on the machine.

- Securing works with vacuum
- Securing works with adhesive tape



- Maximum thickness of works that can be set up or cut varies depending on the selected tool and blade.

Tool	Thickness that can be set	Thickness that can be cut
Pen/swivel cutter	54 mm	0.8 mm
Flat Blade Tool	54 mm	10 mm
Reciprocating cutter	54 mm	50 mm
V-cut cutter	20 mm	20 mm
End mill	54 mm	54 mm

- Load work of sufficient size in accordance with the cut data size. There is a risk of damage to the equipment if drawing is performed outside the work.
- Be sure to set the drawing origin and load the work to ensure that the cut data does not protrude outside the work mounted. There is a risk of damage to the equipment if drawing is performed outside the work.
- Do not place media with a different thickness from that set in the machine on the panel surface. Failure to observe this instruction may damage the equipment.

Securing Works with Adhesive Tape

If vacuum cannot secure works such as thin gaskets or industrial rubber in place when a swivel cutter or Flat Blade Tool is used, use adhesive tape to hold the work in place.



- Use adhesive tape that does not leave a residue of adhesive or tape itself on the cutting panel.

Tape down the work on four sides to secure it.

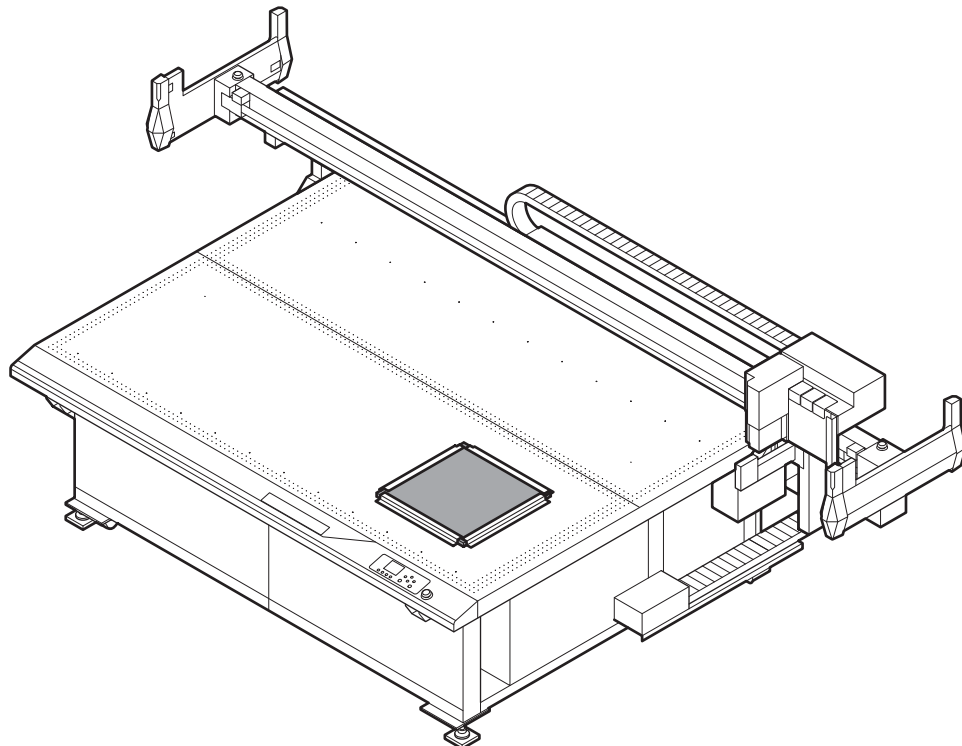

Securing Works with Vacuum

Relatively light works such as thin coated board, corrugated cardboard, or sponge can be held in place by vacuum adhesion.

Important!

- If all the suction holes on the cutting panel are not covered by the work, cover all the suction holes with film or other means as shown below. If some suction holes are not covered, adhesion will be weaker, and the work may not be held securely.

When the work is too small to cover all the suction holes on the cutting panel

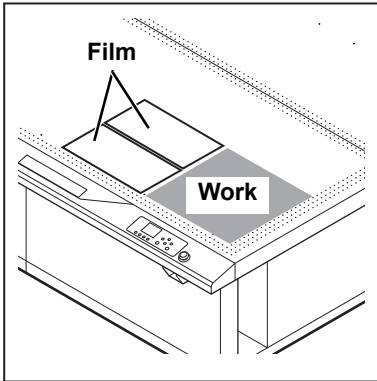

When smaller works are arranged next to each other with a gap between them

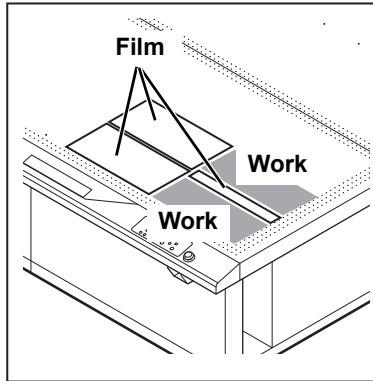

When a work is positioned away from the work guide

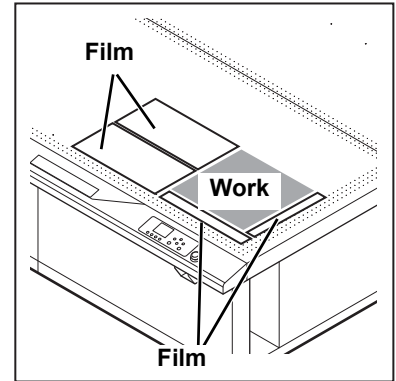

- If you will cut multiple small shapes, carefully cover the areas just cut, as follows. Cutting (or drawing) without taking steps such as this will allow airflow through the openings that were cut, and the work will not be held securely. This will also cause the covering sheets placed over the cut areas to lift away from the work surface, leading to inferior results.
 - (1) Press [LOCAL] to pause cutting (or drafting).
 - (2) Start [VIEW] from jog function selection to retract the head.
 - (3) Using smaller portion of the covering sheet that you have cut, place the sheet over the area just cut.
 - (4) Press the [END/POWER] key to return to local mode
 - (5) Press [REMOTE] to resume cutting (or drafting).

Hint!

- Vacuum on/off can be interlocked with the remote key. (👉 P.1-25)

- 1 Place the work on the cutting panel.

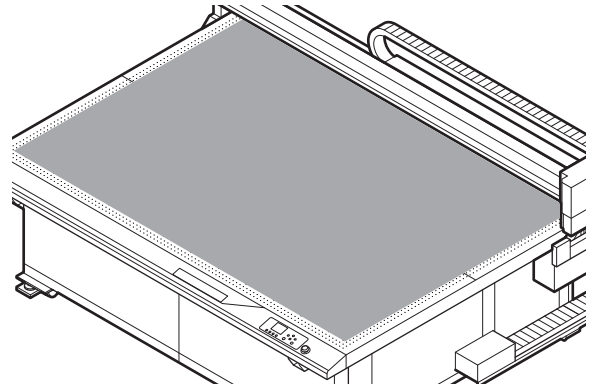

- 2 On the local mode screen, press [VACUUM].

Switch the suction valves to suit the work.

Make sure that the area used for cutting does not extend beyond the effective cutting area.

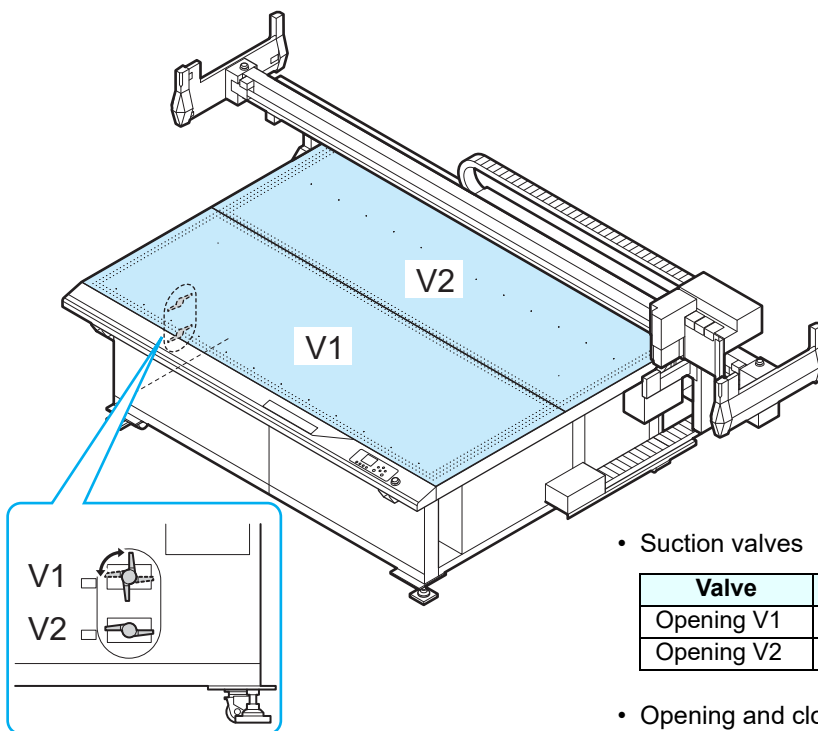

- Suction valves

Valve	Table
Opening V1	Applies suction to area V1
Opening V2	Applies suction to area V2

- Opening and closing suction valves

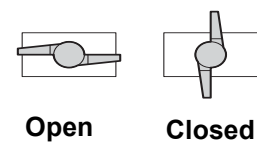

3

Setting Work Thickness

Once the work is set up, set the work thickness based on the thickness of the work used.

Setting work thickness

The following methods are available to set work thickness.

- Automatically set work thickness. "Measuring automatically" (☞ P.3-12)
- Manually enter work thickness. "Entering values manually" (☞ P.3-13)



- When measuring the work thickness automatically, be sure to mount the pen cap on the pen adapter. There is a risk of the pen tip or blade damaging the work if the pen cap is not fitted.

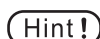

- In continuous or toggle mode, values entered in the continuous mode settings are valid. (Values entered/measured here are disregarded.) (☞ P.4-23)

Measuring automatically

1

Make sure the pen adapter is capped.

- If the cap is not attached, attach it. (☞ P.2-6)

2

Press ▲▼◀▶ on the local mode screen.

- The [JOG Function Selects] screen is displayed.

3

Select [JOG Function Selects] > [Work Thickness].

4

Select [Automatic detection].

5

Press ▲▼◀▶ to align the LED pointer with the position to measure, then press the [ENTER] key.

- Automatic work thickness measurement starts.
- The measurement results are displayed once measurement is complete.

6

Check the measurement results, then press the [ENTER] key.

- The measured thickness value is shown on the local mode screen.



- The work thickness measurement results will vary depending on wear and sinking of the felt. The settings can be altered using the ▲▼ keys before pressing the [ENTER] key for the measurement results.



- The thickness of the felt mat can be altered. (☞ P.4-31) This should be reset if the thickness has changed due to wear.

Entering values manually

1

Check (or measure) the work thickness.

2

Press     on the local mode screen.

- The [JOG Function Selects] screen is displayed.
-

3



Select [JOG Function Selects] > [Work Thickness].

4

Select [Numerical input].

5

Press   to enter the work thickness, then press the [ENTER] key.

- The entered thickness value is shown on the local mode screen.
 -   Keys: Increment/decrement in 0.1 mm steps
 - F1 key: Reduce in 5 mm steps (display - 5 mm)
 - F3 key: Increase in 5 mm steps (display + 5 mm)
-

Cutting Edge Detection

Detects the tip position of the mounted tool. Immediately after turning the machine on, or when the height of the tip position changes after a tool is changed or for other reasons, perform cutting edge detection as follows.

The following methods are available for cutting edge detection.

- Automatic detection: Automatically detects the tip position of the mounted tool.
- Manual detection: Specify the tool tip position using jog operations. Use only if automatic detection is not possible.

Important!

- Cutting edge detection is not possible while cutting is suspended. If cut data remains, use [Data Clear] (☞ P.3-49).

Hint!

- When [Startup Mode (☞ P.4-43)] is set to remote, cutting edge detection is automatically performed immediately after startup.

Automatic detection for all tools

1

Make sure pen adapters are capped.

- If the cap is not attached, attach it. (☞ P.2-6)

2

On the local mode screen, select [MENU].

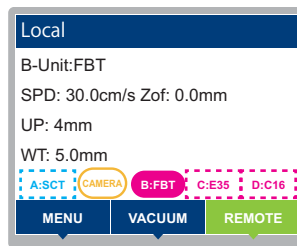

3

Press \triangle ∇ to select [Tool] > [Cutting Edge Detection].

- The cutting edge detection menu is displayed.

4

Select [Auto detect All] and press the [ENTER] key.

- Automatic detection only applies to units on which tools are mounted.
- The first time after startup, ZS sensor operation is checked with the pen adapter before cutting edge detection.

5

After all detection is complete, press the [END/POWER] key several times to return to the local mode screen.

- [Not Det.] is displayed for tools that could not be detected. Make sure the tools are mounted correctly.
- If automatic detection is not possible even with tools mounted correctly, perform manual detection (☞ P.3-15).

Automatically detecting only specified tools

- 1 Press ▲▼ in [Cutting Edge Detection] to select tools for detection.
- 2 With [Automatic detection] selected, press the [ENTER] key.
 - Automatic detection only applies to your specified units.
- 3 After detection is complete, press the [END/POWER] key several times to return to the local mode screen.

Manually detecting only specified tools

- 1 Press ▲▼ in [Cutting Edge Detection] to select tools for detection.
- 2 Press ▲▼ to select [Manual detection], then press the [ENTER] key.
 - Specified units move over the ZS sensor.
- 3 Press the surface of the ZS sensor lightly by hand to confirm that the sensor status display on the screen changes to [ON].

- After the ZS sensor detects contact, the sensor status indicator on the screen changes to [ON] and a buzzer sounds.

Important!

- If sensor status is not displayed correctly, contact your dealer or our sales office or call center.

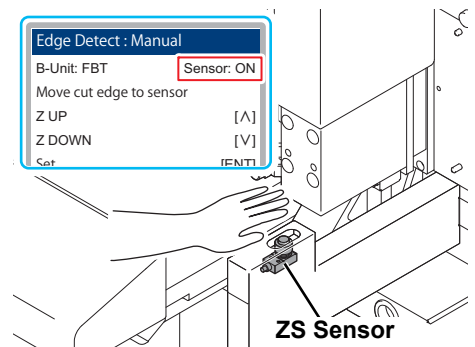

- 4 Press ▲▼ and adjust the tool so that the tip of the tool is at a height to touch the surface of the ZS sensor.

- ▲: Raise the tool.
- ▼: Lower the tool.



- Make sure that the tip of the tool is not lowered to a height where it presses hard against the ZS sensor. Failure to observe these instructions may damage the sensor.

- 5 When the tool tip moves to a height where it touches the surface of the ZS sensor, press the [ENTER] key.

6

To exit, press the [END/POWER] key several times to return to local mode screen.

Selecting Tools

Set the tools to be used for cutting (or drawing).

1 On the local mode screen, press [MENU].

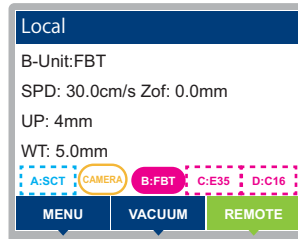

2 Press ▲ ▼ to select [Tool] > [Tool Select], then press the [ENTER] key.

3 Press ▲ ▼ to select the station.

- Setting values:
- Unit A: SCT
- Unit A: PEN
- Unit B: Tool mounted
- Unit C: Tool mounted
- Unit D: Tool mounted

Important!

- If a unit is not mounted, this is indicated in the display. In this case, it cannot be selected.

4 Press the [ENTER] key.

- Tool settings are updated accordingly.

Changing Cutting Conditions

Before starting cutting (or drawing), select the cutting conditions to suit the work and tool used.

1 On the local mode screen, press [MENU].

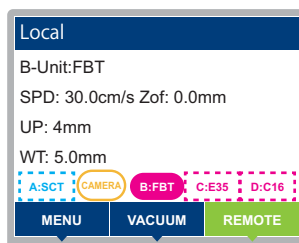

2 Press ▲ ▼ to select [Tool] > [Tool Setting], then press the [ENTER] key.

3 Press ▲ ▼ to select a station, then press the [ENTER] key.

- Setting values: Attached Tool, A-Unit, B-Unit, C-Unit, D-Unit

Hint! • Selecting “Attached Tool” allows the tool to be set to be selected from among the currently mounted tools.

4 Press ▲ ▼ to select the tool.

- For units with many available tools, use << >> to switch screens.
- Configurable tools vary by unit. (☞ Unit and Tool Combinations)

Important! • Regardless of the tools actually mounted, tool settings for each unit can be configured.
• Tool settings are saved on a per-unit basis. They are not applied to other units.

5 Press the [ENTER] key.

- The settings are saved.
- To exit without saving, press the [END/POWER] key.

6 Press ▲ ▼ to display the cutting condition to set, then press the [ENTER] key.

- Items displayed vary by tool. (☞ Setting items)

7 Press ▲ ▼ to set a setting value, then press the [ENTER] key.

- The settings are saved.
- To exit without saving, press the [END/POWER] key.

8 To set other items, repeat steps 3 to 7.

- For details on setting items, see “Setting items”.

9 Press the [END/POWER] key after all settings are complete.

Setting items

Setting items for cutting conditions vary by tool.

Setting item	Tool type							Setting value	Details	
	Swivel cutter	Pen	Reciprocating cutter	Flat Blade Tool	Crease Tool	V-cut 45°	V-cut angle selection			Router unit
Cut (draw) speed	<input type="radio"/>	<input type="radio"/>	<input type="radio"/>	<input type="radio"/>	<input type="radio"/>	<input type="radio"/>	<input type="radio"/>	<input type="radio"/>	0.1 to 100 (cm/s)	Speed of tool movement in the X or Y direction. Varies by tool, work, and the size of shapes.
Cut (draw) press	<input type="radio"/>	<input type="radio"/>	<input type="radio"/>	<input type="radio"/>	<input type="radio"/>	<input type="radio"/>	<input type="radio"/>	<input type="radio"/>	20 to 150 g (Up to 100: 5 g, 100 to 150: 10 g increments)	Pressure at which the tool cuts workpieces.
	<input type="radio"/>	<input type="radio"/>	<input type="radio"/>	<input type="radio"/>	<input type="radio"/>	<input type="radio"/>	<input type="radio"/>	<input type="radio"/>	20 to 1000 g (Up to 100: 5 g, 100 to 400: 10 g increments, 400 or more: 50 g increments)	
Cutting blade Offset	<input type="radio"/>	<input type="radio"/>	<input type="radio"/>	<input type="radio"/>	<input type="radio"/>	<input type="radio"/>	<input type="radio"/>	<input type="radio"/>	0.00 to 2.50 (in 0.05 mm increments)	Amount by which the tip of the swivel cutter is offset. Varies depending on blade wear.
Adj-prs Offset	<input type="radio"/>	<input type="radio"/>	<input type="radio"/>	<input type="radio"/>	<input type="radio"/>	<input type="radio"/>	<input type="radio"/>	<input type="radio"/>	-9 to 9 (in 1-unit increments)	Set when there are uncut portions at the beginning and end of cuts, and in other situations.
Dummy cut	<input type="radio"/>	<input type="radio"/>	<input type="radio"/>	<input type="radio"/>	<input type="radio"/>	<input type="radio"/>	<input type="radio"/>	<input type="radio"/>	ON, OFF	When the power is turned on with the swivel cutter set as the tool, or when the swivel cutter is selected, cuts are made outside the effective cutting area, so that the swivel cutter blade is directed in the direction of travel.
Up speed	<input type="radio"/>	<input type="radio"/>	<input type="radio"/>	<input type="radio"/>	<input type="radio"/>	<input type="radio"/>	<input type="radio"/>	<input type="radio"/>	AUTO (same value as cutting speed), 5 cm/s, 10 to 100 cm/s (in 10cm/s increments)	Sets the speed of head movement when the tool is raised. With [AUTO] selected, the up speed corresponds to the cutting speed setting value in the cutting conditions.
Up height	<input type="radio"/>	<input type="radio"/>	<input type="radio"/>	<input type="radio"/>	<input type="radio"/>	<input type="radio"/>	<input type="radio"/>	<input type="radio"/>	Full up, 2 to 40 mm	Sets the height to which tools on stations B to D are raised.
Over Cut	<input type="radio"/>	<input type="radio"/>	<input type="radio"/>	<input type="radio"/>	<input type="radio"/>	<input type="radio"/>	<input type="radio"/>	<input type="radio"/>	OFF, 0.1 to 1.0 mm (in 0.1 mm increments)	Intentionally overlapping the start and end points prevents the work from being left uncut.
Z origin Offset	<input type="radio"/>	<input type="radio"/>	<input type="radio"/>	<input type="radio"/>	<input type="radio"/>	<input type="radio"/>	<input type="radio"/>	<input type="radio"/>	-10.0 mm to 4.2 mm	Amount by which cutting is offset relative to the Z-axis origin. To ensure that works are fully cut, we recommend setting a positive value. (To the extent of slightly scraping the felt mat.) Note that this setting will be disabled if the pressure level is set to anything other than OFF.
	<input type="radio"/>	<input type="radio"/>	<input type="radio"/>	<input type="radio"/>	<input type="radio"/>	<input type="radio"/>	<input type="radio"/>	<input type="radio"/>	-20.0 mm to 4.2 mm	
Smooth Control	<input type="radio"/>	<input type="radio"/>	<input type="radio"/>	<input type="radio"/>	<input type="radio"/>	<input type="radio"/>	<input type="radio"/>	<input type="radio"/>	ON, OFF	If there are continuous minute line segments, these are controlled to ensure smooth drawing results. It also reduces the degree to which the work is picked by the tool. Disabling will result in rough edges appearing in the drawing results.

Setting item	Tool type							Setting value	Details
	Swivel cutter	Pen	Reciprocating cutter	Flat Blade Tool	Crease Tool	V-cut 45°	V-cut angle selection		
Vibration level			<input type="radio"/>					Low, Mid, High	Select the reciprocating cutter vibration frequency in a range of three levels.
Start correct			<input type="radio"/>	<input type="radio"/>				0.00 to 2.50 (in 0.01 mm increments)	Amount of cutting start position offset when the tool is lowered. Setting a larger offset for thick works makes separation easier by cutting from the front. Check the finish and adjust as needed.
						<input type="radio"/>	<input type="radio"/>	0.00 to 5.00 (in 0.01 mm increments)	
End correct			<input type="radio"/>	<input type="radio"/>				0.00 to 2.50 (in 0.01 mm increments)	Amount of cutting end position offset when the tool is raised. Setting a larger offset for thick works makes separation easier by cutting extra at the end. Check the finish and adjust as needed.
						<input type="radio"/>	<input type="radio"/>	0.00 to 5.00 (in 0.01 mm increments)	
Up angle			<input type="radio"/>	<input type="radio"/>	<input type="radio"/>			0 to 180° (in 1° increments)	Sets the minimum angle to raise the tool and change the direction, when changing the cutting (creasing) direction. This reduces work prying by tools. Operation may not match the setting value exactly due to the margin of error in converting to units used for control.
Double roller					<input type="radio"/>			OFF, 0.1 to 3.0 mm (in 0.1 mm increments)	Draws two ruled lines, centered on the original data and offset by the setting value.
Pressure level				<input type="radio"/>				OFF, press LV. 1 to 31	Sets the crease tool pressure.
Press correction					<input type="radio"/>			0 to 10 (in 1-unit increments)	Corrects downward pressure when cutting (creasing) thick works. Adding the pressure compensation value to a previously set pressure value ensures that the work is cut when the tool is lowered.
Y press correction					<input type="radio"/>			-20 to 20 (in 1-unit increments)	Pressure values in the Y direction can be corrected to crease with a different pressure than in the X direction. When corrugated cardboard is creased, works are set up with flutes in the Y direction and can be creased with less pressure than in the X direction.
Edge angle							<input type="radio"/>	VAS: 0°, 15°, 22.5°, 30°, 45°	Sets the blade angle for V-cut cutting.
Pen No. assignment	<input type="radio"/>	<input type="radio"/>	<input type="radio"/>	<input type="radio"/>	<input type="radio"/>	<input type="radio"/>	<input type="radio"/>	No. 1 to No. 8*1	Sets the tool on the machine to which the pen number in data will be assigned.

*1: Pen no. assignment options as follows.

Station	Tool	Max. no. of groups saved
A	SCT	1
A	PEN	1
B, C, D	FBT	3
B, C	E12 / E35 / E60	2
B, C, D	C16/C26/C60/C6A	3
B, C, D	V45/VAS	3
D	R10	1

Setting item	Tool type							Setting value	Details	
	Swivel cutter	Pen	Reciprocating cutter	Flat Blade Tool	Crease Tool	V-cut 45°	V-cut angle selection			Router unit
Rotation speed								○	18000 to 40000 rpm (in 1000-unit increments)	The number of revolutions per minute for router unit rotation.
Brush position adjustment								○	-10.0 to 5.0 mm (in 0.1 increments)	Adjust the position of the brush on the end of the router unit dust collector nozzle with respect to the work surface. Set a negative value to increase the gap between the brush and the work surface. Set a positive value to decrease the gap between the brush and the work surface.
R5 arc speed		○							OFF, 10, 20 (mm/s)	Speed for cutting arcs with a radius of less than 5 mm. When set to [Off], the previously set speed is used for cutting.
			○	○					OFF, 0.5 to 20.0 (mm/s)	
R10 arc speed		○							OFF, 10 to 50 (mm/s)	Speed for cutting arcs with a radius of 5 mm or more but less than 10 mm. When set to [Off], the previously set speed is used for cutting.
			○	○					OFF, 0.5 to 20.0 (mm/s)	
R15 arc speed		○							OFF, 10 to 100 (mm/s)	Speed for cutting arcs with a radius of 10 mm or more but less than 15 mm. When set to [Off], the previously set speed is used for cutting.
			○	○					OFF, 0.5 to 20.0 (mm/s)	
R20 arc speed		○							OFF, 10 to 150 (mm/s)	Speed for drawing arcs with a radius of 15 mm or more but less than 20 mm. When set to [Off], the previously set speed is used for drawing.
R30 arc speed		○							OFF, 10 to 200 (mm/s)	Speed for drawing arcs with a radius of 20 mm or more but less than 30 mm. When set to [Off], the previously set speed is used for drawing.
R40 arc speed		○							OFF, 10 to 250 (mm/s)	Speed for drawing arcs with a radius of 30 mm or more but less than 40 mm. When set to [Off], the previously set speed is used for drawing.
R50 arc speed		○							OFF, 10 to 300 (mm/s)	Speed for drawing arcs with a radius of 40 mm or more but less than 50 mm. When set to [Off], the previously set speed is used for drawing.
R100 arc speed		○							OFF, 10 to 300 (mm/s)	Speed for drawing arcs with a radius of 50 mm or more but less than 100 mm. When set to [Off], the previously set speed is used for drawing.



- With sorting enabled, the [R** arc speed] setting specifying arc cutting speed is not applied, because shapes are not recognized as arcs.
For this reason, when setting [R** arc speed], disable [Sorting]. (☞ P.4-14)

Adjusting Tools

Tool adjustment is required in cases such as when the start and end points do not match when drawing (or cutting) with the machine.

Hint! • In toggle mode, tool adjustment drawing is only possible in the front area.

The following three tool adjustments are available

- (1) Cutter adjustment: Adjusts cutters.
- (2) Roller adjustment: Adjusts rollers.
- (3) Circle Θ correction: Adjustment if start and end points do not match when drawing circles.

Adjusting Cutters

Adjusts cutters.

For cutter adjustment, make each of the following adjustments.

Hint! • Rollers can be adjusted the same way.
• Tool adjustment for the router unit (R10) consists of offset adjustment only.

B-Unit:FBT	
CENTER A	0.00mm
CENTER B	0.00mm
OFFSET X	0.0mm
OFFSET Y	0.0mm
THETA ANGLE	0.0°

<< TEST >>

1 Center Adjust P.3-23	Perform this adjustment after blade or tool replacement.
2 Offset Adjust P.3-28	Adjusts in case of cutter or tool misalignment.
3 Theta Angle Adjust P.3-31	Adjusts the angle of rotation for cutters or rollers.

● For more efficient cutter adjustment, follow this sequence.

3 ⇔ **1** ⇔ **2** ⇔ **3** ⇔ **1** ⇔ **2**

This sequence is one recommended example. Adjust in a sequence that is most convenient for you.

Center adjustment (tangential unit)

Check test patterns drawn by a cutter or roller to correct misalignment due to eccentricity.

Hint! • When adjusting the roller, the pen should be mounted on unit A in advance.

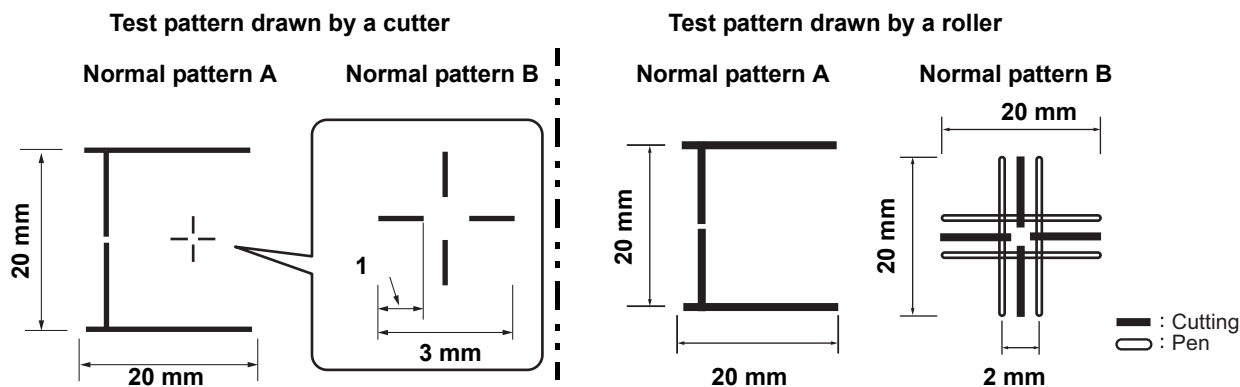

1 On the local mode screen, press [MENU].

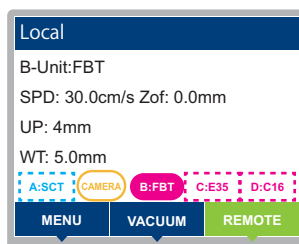

2 Press \triangle ∇ to select [Tool] > [Tool Adjust], then press the [ENTER] key.

3 Press \triangle ∇ to select a unit, then press the [ENTER] key.

- Setting values: B, C, D
- Tools currently mounted in the units are indicated.

4 Press [TEST].

5 Press \triangle ∇ to select [Center Adjust], then press the [ENTER] key.

- To change the drawing position from the current position, perform the procedures described in steps 6 to 7 below.

6 Press the [SEL] key.

7 Press \triangle ∇ \leftarrow \rightarrow to move the head into position for drawing, then press the [ENTER] key.

8

When the confirmation screen is displayed, press the [ENTER] key.

- Cutting is executed.
-

9

Press ▲▼ to select [Center A] or B, then press the [ENTER] key.

10

Press ▲▼, then enter a correction value.

- CENTER A: -5.00 mm to +5.00 mm
 - CENTER B: -5.00 mm to +5.00 mm
 - For details, see “How to adjust using center adjustment” on the next page.
-

11

Press the [ENTER] key.

- To exit without saving, press [END/POWER].
 - To enter other correction values, press ▲ or ▼ to select the correction value to be entered, then repeat the procedure from step 10 onward.
 - To exit, press [END/POWER] several times.
-

How to adjust using center adjustment

Eccentricity can be adjusted with the following screen displayed.

B-Unit:FBT	
CENTER A	0.00mm
CENTER B	0.00mm
OFFSET X	0.0mm
OFFSET Y	0.0mm
THETA ANGLE	0.0°
<<	TEST >>

CENTER A adjustment

Adjustment to align the center of the cutter (or roller) with the cutting direction (back and forth) of the center of the holder.
Press \blacktriangle \blacktriangledown to adjust. (0.01 mm pitch)

CENTER B adjustment

Adjustment to align the center of the cutter (or roller) with the cutting direction (Left and right, blade thickness direction) of the center of the holder.
Press \blacktriangle or \blacktriangledown to adjust. (0.01 mm pitch)

[Center adjustment pattern]

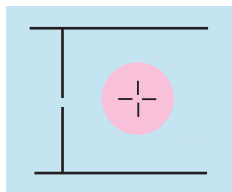

Pattern A

Pattern B

[Adjustment value of CENTER A, CENTER B]

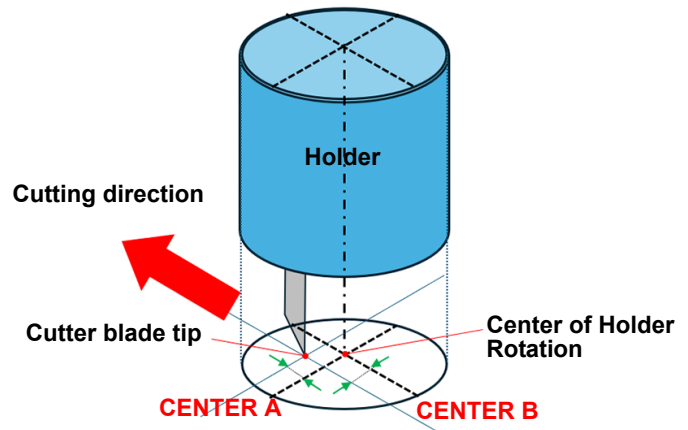

Hint! • Adjust CENTER B before adjusting CENTER A.

1

Check if the lines facing each other (1 and 3, 2 and 4) are aligned in Pattern B and adjust CENTER B.

[Pattern B]

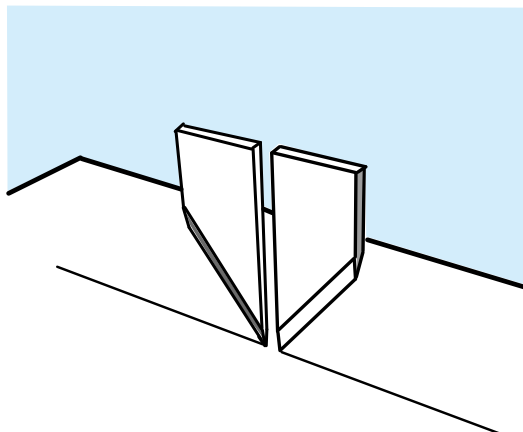
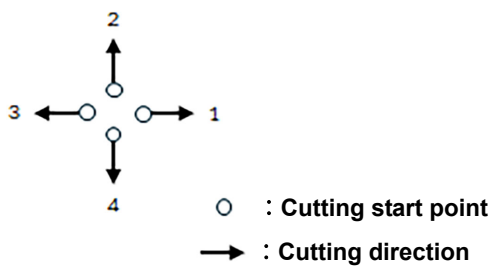

[Adjustment using pattern B]

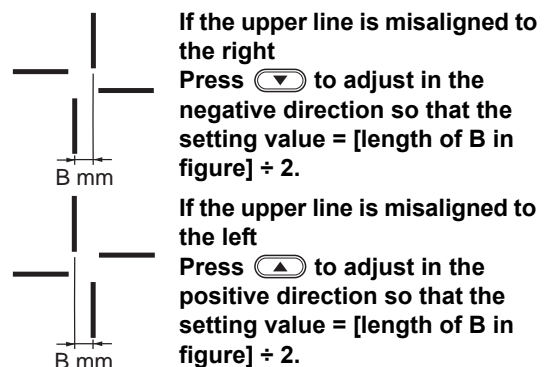

[To adjust CENTER B to negative]

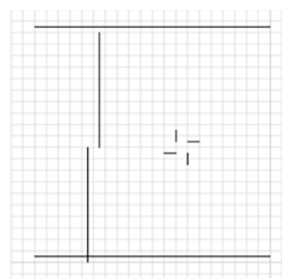

[To adjust CENTER B to positive]

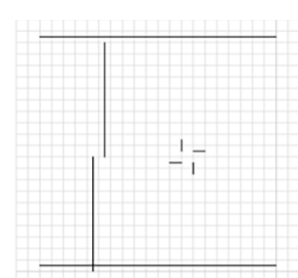

2

Check that the vertical bars (3 and 4) against the horizontal bars (1 and 2) do not jump out or away from each other in Pattern A, and adjust CENTER A.

[Pattern A]

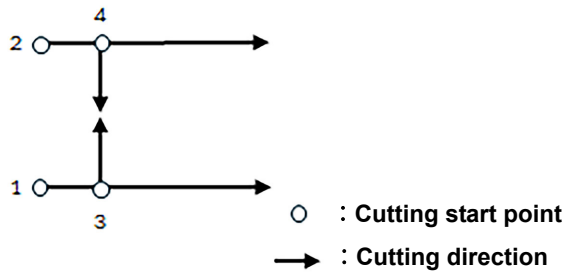

[Adjustment using pattern A]

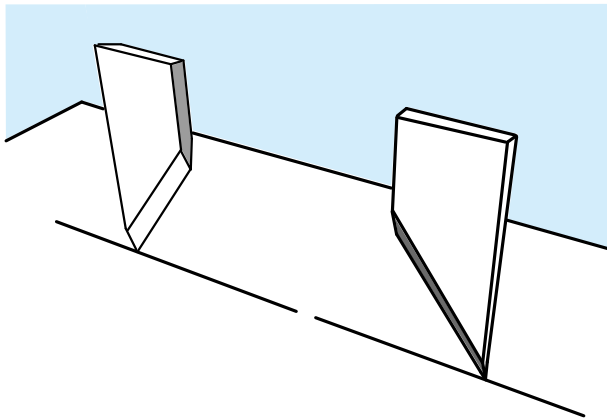
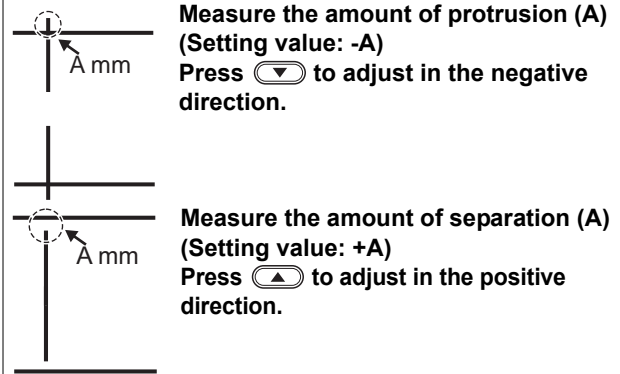

[To adjust CENTER A to negative]

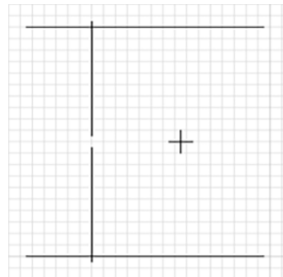

[To adjust CENTER A to positive]

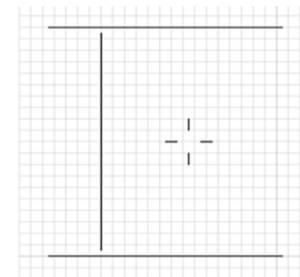

Hint!

- If there is an imbalance in the lengths of the vertical bars (3 and 4) popping out and apart at their starting points, the adjustment of CENTER B is insufficient. Return to step 1 and perform the adjustment again.

V cutter center adjustment procedure

The V cutter adjustment is performed on the work surface, so move the Z-axis origin by a distance corresponding to the work thickness before cutting. However, if the blade is positioned in relation to the work surface as follows, fine adjust the work thickness value (or Z origin offset).







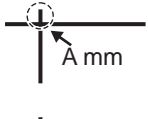

- If the blade does not reach the work surface, reduce the work thickness value.
- If the blade cuts into the work surface, increase the work thickness value.

Important!

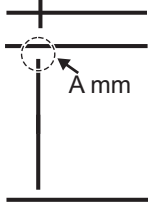
- Adjusting the work surface position will vary how the pattern appears, so the value entered should ideally be as close to the actual work thickness as possible.

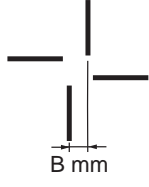
Hint!

- The positive and negative signs for the V cutter correction values will be opposite to those for other tools.

Adjustment using pattern A	Adjustment using pattern B
 <p>Measure the amount of protrusion (A) (Setting value: +A) Press  to adjust in the positive direction.</p>  <p>Measure the amount of separation (A) (Setting value: -A) Press  to adjust in the negative direction.</p>	 <p>If the upper line is misaligned to the right Press  to adjust in the positive direction so that the setting value = [length of B in figure] ÷ 2.</p>  <p>If the upper line is misaligned to the left Press  to adjust in the negative direction so that the setting value = [length of B in figure] ÷ 2.</p>

Offset adjustment (tangential unit)

Compensate for misalignment by comparing a test pattern drawn with a pen to a test pattern drawn by a cutter or other tool.

Hint! • Mount the pen on unit A in advance.

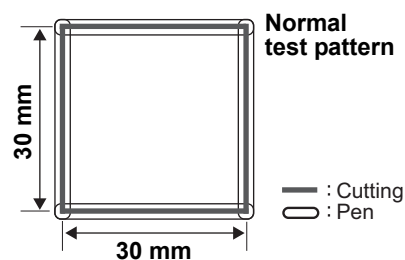

1 On the local mode screen, press [MENU].

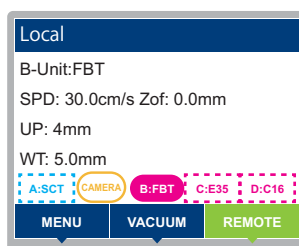

2 Press \triangle ∇ to select [Tool] > [Tool Adjust], then press the [ENTER] key.

3 Press \triangle ∇ to select a unit, then press the [ENTER] key.

- Setting values: B, C, D
- Tools currently mounted in the units are indicated.

4 Press [TEST].

5 Press \triangle ∇ to select [Offset Adjust], then press the [ENTER] key.

- To change the drawing position from the current position, perform the procedures described in steps 6 to 7 below.

6 Press the [SEL] key.

7 Press \triangle ∇ \leftarrow \rightarrow to move the head into position for drawing, then press the [ENTER] key.

8 When the confirmation screen is displayed, press the [ENTER] key.

- Cutting is executed.

9 Press \triangle ∇ to select [Offset X] or [Offset Y], then press the [ENTER] key.

10**Press \blacktriangle \blacktriangledown , then enter a correction value.**

OFFSET X: -20.0 mm to +20.0 mm

OFFSET Y: -20.0 mm to +20.0 mm

- For details, see “How to adjust using offset adjustment” on the next page.
- For R10, the input screen is different. See “Adjusting the Router Unit R10.” (👉 P.6-11)

11**Press the [ENTER] key.**

- To exit without saving, press [END/POWER].
- To enter other correction values, press \blacktriangle or \blacktriangledown to select the correction value to be entered, then repeat the procedure from step 10 onward.
- To exit, press [END/POWER] several times.

How to adjust using offset adjustment

Offset adjustment is possible with the following screen displayed.

B-Unit:FBT	
CENTER A	0.00mm
CENTER B	0.00mm
OFFSET X	0.0mm
OFFSET Y	0.0mm
THETA ANGLE	0.0°
<<	TEST >>

OFFSET X adjustment

Distance from pen to cutter or other tool in the X direction.
Press \blacktriangle \blacktriangledown to adjust. (0.1 mm pitch)

OFFSET Y adjustment

Distance from pen to cutter or other tool in the Y direction.
Press \blacktriangle \blacktriangledown to adjust. (0.1 mm pitch)

- (1) Measure the misalignment between the shapes drawn by the pen and the cutter (roller).
- (2) Enter the adjustment value.

Horizontal misalignment relative to the operating panel	Vertical misalignment relative to the operating panel
<p>— : Pen drawing - - - : Cutter, etc.</p> <p>Y' mm Y mm</p> <p>② ①</p> <p>X-axis direction</p> <p>Y-axis direction</p> <p>If the drawing from a cutter or other tool is misaligned to the right (dotted line labeled 1) Press \blacktriangle to adjust so that the setting value = [value displayed] + [Y mm]. If the drawing from a cutter or other tool is misaligned to the left (dotted line labeled 2) Press \blacktriangledown to adjust so that the setting value = [value displayed] - [Y' mm].</p>	<p>— : Pen drawing - - - : Cutter, etc.</p> <p>X' mm</p> <p>②</p> <p>X mm</p> <p>①</p> <p>X-axis direction</p> <p>Y-axis direction</p> <p>If the drawing from a cutter or other tool is misaligned downward (dotted line labeled 1) Press \blacktriangle to adjust so that the setting value = [value displayed] + [X mm]. If the drawing from a cutter or other tool is misaligned to upward (dotted line labeled 2) Press \blacktriangledown to adjust so that the setting value = [value displayed] - [X 'mm].</p>

Performing theta angle adjustment

Adjust the angle of rotation by comparing a test pattern drawn with a pen to a test pattern drawn by a cutter or roller.

Hint!

- The values in parentheses in the figure below indicate the sizes when a roller is used.
- First, mount the pen on unit A and remove the pen cap.
- When using the V-cut tool, the optimal θ adjustment value may vary depending on the type of media used. If issues such as wavy straight lines are observed during actual cutting, use the procedure described in “V-CUT straight line θ correction value selection.” (P.8-17)

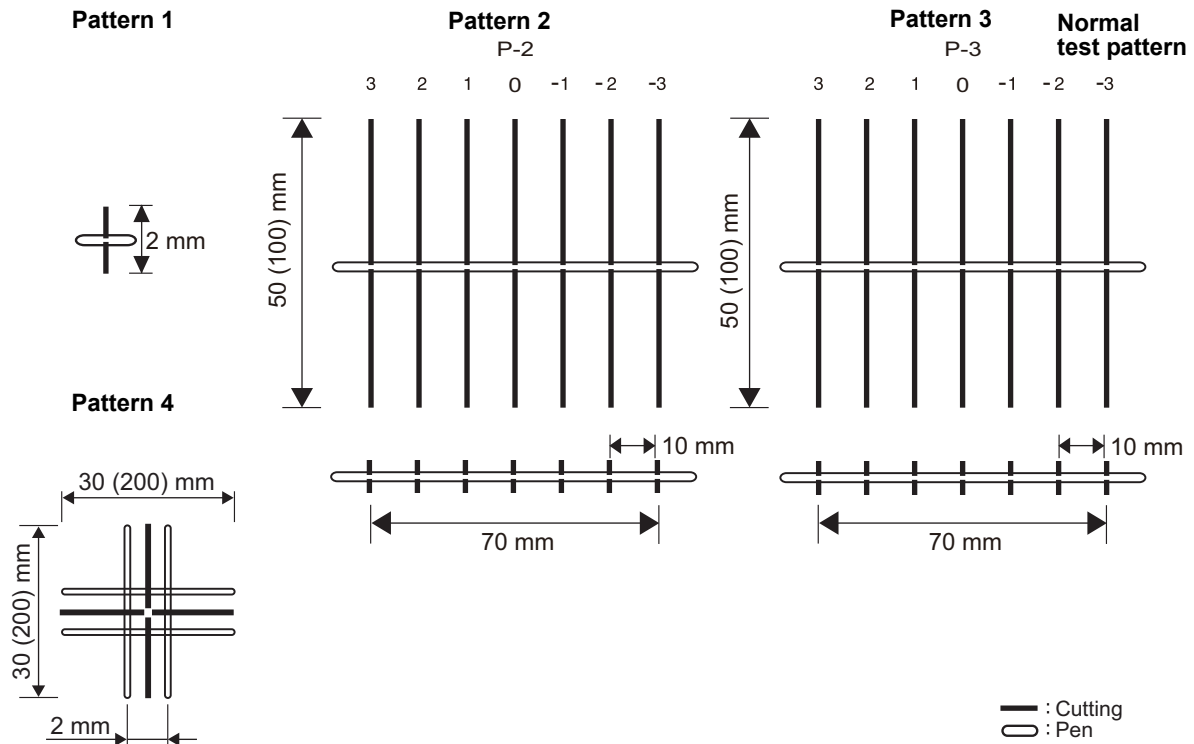

Adjust using the four theta angle adjustment patterns in sequence from pattern 1.

Adjust in the sequence Pattern 1 → Pattern 2 → Pattern 3 to achieve increasingly fine angle adjustment. (Pattern 4 is used to check the adjustment.)

Item	Description
Pattern 1	Lower the tool at a distance of 2 mm in the 0° and 180° directions. Draw crosshairs at the center as a reference. The angle can then be input as a numerical value, enabling a correction angle to be entered depending on the cutting results.
Pattern 2	Perform facing cutting by altering the adjustment value within a range of $\pm 3.0^\circ$ centering around the current θ adjustment value. Selecting the number with the smallest difference adjusts the θ angle to the closest value. +3.0° to -3.0° (in 1° steps) (Plotting using the current adjustment value for zero) If the tool is a crease tool (C16, C26, C60, C6A), the length of the upper and lower patterns will be changed from 50 mm to 100 mm.
Pattern 3	Perform facing cutting by altering the adjustment value within a range of $\pm 0.9^\circ$ centering around the current θ adjustment value. Selecting the number with the smallest difference adjusts the θ angle to the closest value. +0.9° to -0.9° (in 0.3° steps) (Plotting using the current adjustment value for zero) If the tool is a crease tool (C16, C26, C60, C6A), the length of the upper and lower patterns will be changed from 50 mm to 100 mm.
Pattern 4	Corrects the angle of rotation. (Used to check the adjustment results.)

1 On the local mode screen, press [MENU].

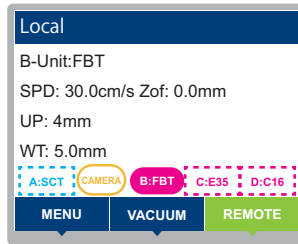

2 Press \triangle ∇ to select [Tool] > [Tool Adjust], then press the [ENTER] key.

3 Press \triangle ∇ to select a unit, then press the [ENTER] key.

- Setting values: B, C, D
- Tools currently mounted in the units are indicated.

4 Press [TEST].

5 Press \triangle ∇ to select [Theta Angle Adjust], then press the [ENTER] key.

6 Press \triangle ∇ to select [Pattern 1—4], then press the [ENTER] key.

7 Press the [SEL] key.

8 Press \triangle ∇ \triangleleft \triangleright to move the head into position for drawing, then press the [ENTER] key.

9 When the confirmation screen is displayed, press the [ENTER] key.

- Cutting is executed.

10 Press \triangle ∇ to select [Theta Angle Adjust], then press the [ENTER] key.0

11 Press \triangle ∇ , then enter a correction value.

- Setting values:
[Pattern 1, Pattern 4]: -45.0° to $+45.0^\circ$
[Pattern 2, Pattern 3]: -3 to $+3$
- For details, see “Theta angle adjustment: Adjustment procedure for Pattern 1 to 4” on the next page.

12

Press the [ENTER] key.

- To exit without saving, press [END/POWER].
 - To exit, press [END/POWER] several times.
-

Theta angle adjustment: Adjustment procedure for Pattern 1 to 4

Theta angle adjustment is possible with the following screen displayed.

Press ▲ ▼ to adjust. →

B-Unit:FBT	
CENTER A	0.00mm
CENTER B	0.00mm
OFFSET X	0.0mm
OFFSET Y	0.0mm
THETA ANGLE	0.0°
<<	TEST >>

Pattern 1:

- (1) Measure misalignment between the shapes drawn by the pen and the cutter (or roller).
- (2) Adjust as needed.

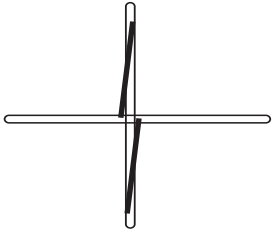
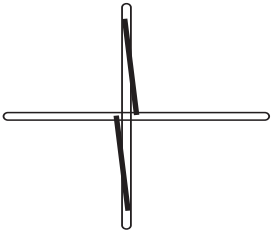
When skewed clockwise	When skewed counterclockwise
 <p>Press ▲ to increase the cutter theta value.</p>	 <p>Press ▼ to decrease the cutter theta value.</p>

Pattern 4:

- (1) Measure misalignment between the shapes drawn by the pen and the cutter (or roller).
- (2) Adjust as needed.

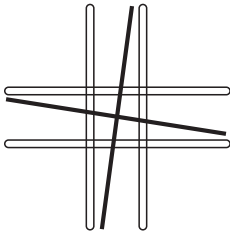
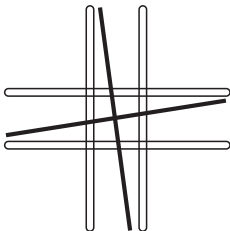
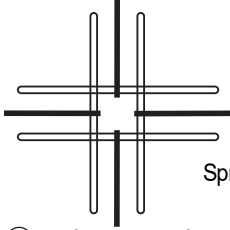
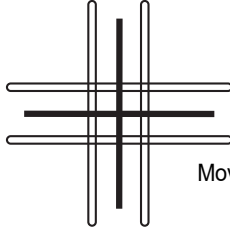
When skewed clockwise	When skewed counterclockwise
 <p>Press ▲ to increase the cutter theta value.</p>	 <p>Press ▼ to decrease the cutter theta value.</p>
V-cut	
When skewed clockwise	When skewed counterclockwise
 <p>Press ▲ to increase the cutter theta value.</p> <p style="text-align: right;">Spread outward</p>	 <p>Press ▼ to decrease the cutter theta value.</p> <p style="text-align: right;">Move inward</p>

Pattern 2, Pattern 3:

Theta angle adjustment is possible with the following screen displayed.

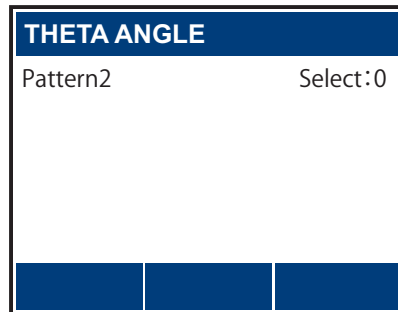

- (1) Measure misalignment between the shapes drawn by the pen and the cutter (or roller).
- (2) Enter the value (-3 to 3) for the row with the smallest difference in the vertical facing cutting.

● Pattern 2

- θ adjustment range: $+3.0^\circ$ to -3.0° (in 1° steps)
- Setting: -3 to 3

θ angle	$+3.0^\circ$	$+2.0^\circ$	$+1.0^\circ$	0	-1.0°	-2.0°	-3.0°
Setting value	3	2	1	0	-1	-2	-3

● Pattern 3

- θ adjustment range: $+0.9^\circ$ to -0.9° (in 0.3° steps)
- Setting: -3 to 3

θ angle	$+0.9^\circ$	$+0.6^\circ$	$+0.3^\circ$	0	-0.3°	-0.6°	-0.9°
Setting value	3	2	1	0	-1	-2	-3

P-2(P-3)

3	2	1	0	-1	-2	-3
---	---	---	---	----	----	----

Setting value

Check using magnifying glass

OK *1	OK	OK *1

Enter the value (-3 to 3) for the row where the cut is the closest to the "OK" sample.

*1: When θ adjustment is OK and B alignment is unsatisfactory

NG		

Pattern 1

Hint!

- Select a point where the cut line is perpendicular to the datum line (pen) rather than where the blade edge closely aligns.
- For V cutting, the drawing results for pattern 1 will tend to be as shown below. If adjustment is satisfactory, as a guide, note that cuts are made at a position approximately ± 1 mm from the line.

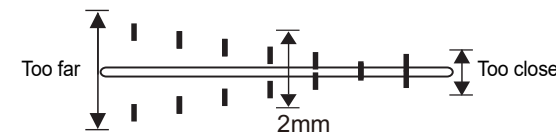

Circle Θ Correction

If the start and end points are misaligned when a perfect circle is cut, correct the misalignment as follows.

Performing circle Θ correction

The machine can correct misalignment for six circles of different radii.

Type of circle for correction	Setting value	Test pattern size
Radius < 5 mm	-20° to +20°	Radius = 3 mm
5 mm ≤ Radius < 10 mm	-20° to +20°	Radius = 5 mm
10 mm ≤ Radius < 15 mm	-9.8° to +9.8°	Radius = 10 mm
15 mm ≤ Radius < 20 mm	-9.8° to +9.8°	Radius = 15 mm
20 mm ≤ Radius < 50 mm	-9.8° to +9.8°	Radius = 20 mm
50 mm ≤ Radius < 100 mm	-9.8° to +9.8°	Radius = 50 mm
100 mm ≤ Radius	-9.8° to +9.8°	Radius = 100 mm

Important!

- Correction may not be available depending on the software used.
- Set the arc theta correction value to [On] in advance.
The value corrected here will not be applied in drawing (or cutting) unless correction is set to [On].

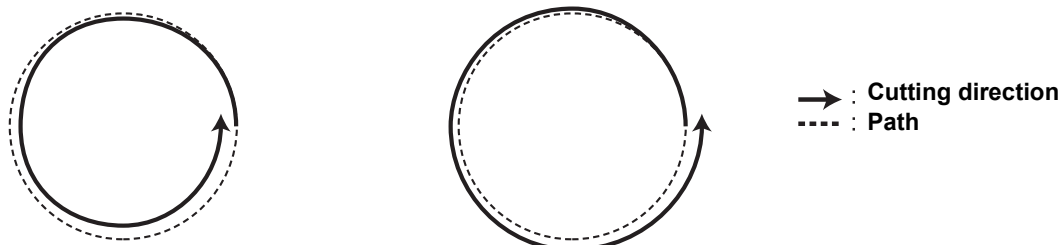

- Values of circle θ correction are automatically calculated based on the radius of circles to draw. Besides entering the correction value for the target range, also enter correction values for the ranges that are smaller and larger.

Example:

- For a radius of 4.5 mm, set correction values for [Radius < 5 mm] and [5 mm ≤ Radius < 10 mm]
- For a radius of 10.5 mm, set correction values for [10 mm ≤ Radius < 15mm] and [15 mm ≤ Radius < 20mm]

1

On the local mode screen, press [MENU].

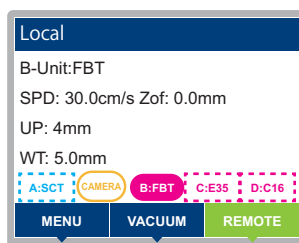

2

Press \uparrow \downarrow to select [Tool] > [Tool Adjust], then press the [ENTER] key.

3

Press \uparrow \downarrow to select a unit, then press the [ENTER] key.

- Setting values: B, C, D
- Tools currently mounted in the units are indicated.

4 Press \blacktriangle \blacktriangledown to select [Circle Theta Adjust], then press the [ENTER] key.

5 Press [TEST].

6 Press \blacktriangle \blacktriangledown to select the circle for correction.

- Setting values: $R < 5$, $5 \leq R < 10$, $10 \leq R < 15$, $15 \leq R < 20$, $20 \leq R < 50$, $50 \leq R < 100$, $R \geq 100$
- To change the drawing position from the current position, perform the procedures described in steps 8 to 9 below.

7 Press \blacktriangle \blacktriangledown to select the rotation direction for drawing a circle.

- Setting values: Counterclockwise, Clockwise
- Select to suit the rotation direction of the application used.

Important!

8 Press the [SEL] key.

9 Press \blacktriangle \blacktriangledown \blacktriangleleft \blacktriangleright to move the head into position for drawing, then press the [ENTER] key.

10 When the confirmation screen is displayed, press the [ENTER] key.

- Cutting is executed.

11 Press \blacktriangle \blacktriangledown to select the type of circle for correction, then press the [ENTER] key.

12 Press \blacktriangle \blacktriangledown to enter the correction value while checking the cutting results.

- **Setting values:** $-X.00^\circ$ to $+X.00^\circ$ (see table on preceding page for input range)
- For details, refer to "How to perform circle theta correction".

13 Press the [ENTER] key.

- To exit without saving, press [END/POWER].
- For adjustment of other circles, press \blacktriangle \blacktriangledown to display the screen for adjustment and repeat step 5 onward.
- To exit, press [END/POWER] several times.

How to perform circle theta correction

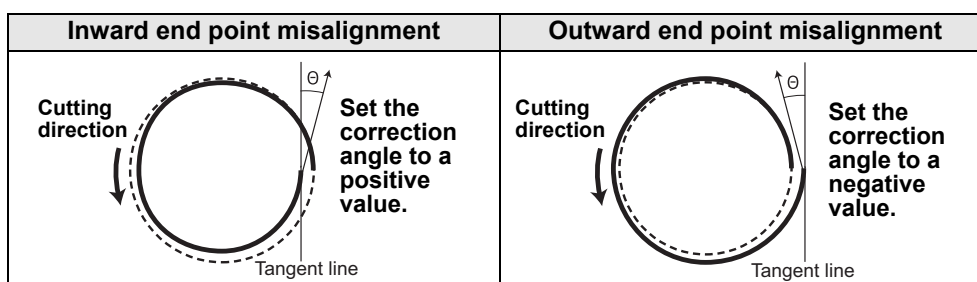

Important!

- The machine will correct to the inner and outer sides of the direction of travel regardless of the rotation direction.

Test Cutting

After changing cutting conditions or switching tools, make a test cut to check the following items. For details, see “Checking tool status” (P.3-39).

No.	Item to check	Point to check
(1)	Cutting (or drawing) conditions are suitable	The work is cut correctly, the drawing is not smudged, etc.
(2)	The tool is mounted straight	Tools that are eccentric will cause misalignment in cutting or other operations
(3)	Tools produce complementary results	When a Flat Blade Tool is used to cut along a drawing, the drawing and the cut pattern match, for example

Hint! • In toggle mode, test cut drawing is only possible in the front area.

1

On the local mode screen, press [TEST CUT].

• Press the [SEL] key to switch the function of the [FUNCTION] key.

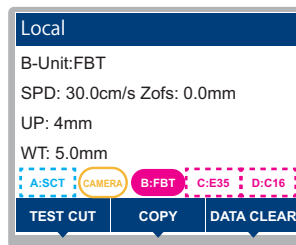

2

Press the [ENTER] key.

• Test cutting begins.
• After cutting, the machine returns to local mode screen.

3

Check the cutting results

• This process is finished if the results are normal.

Checking tool status

Make a test cut using the tool selected with the [Tool Select] function. Items to check for each tool are as follows.

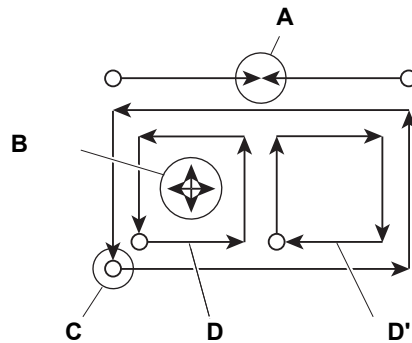

Pen (only standard unit)

Point to check	Cause	Corrective action	Reference page
Lines do not meet at A	Pen is incorrectly mounted	Fully tighten the holder screw.	P.2-4
Lines are broken or faint	Out of ink	Replace the pen with a new one.	P.2-4
	Weak pressure	Increase [Draw Press] in the cutting conditions.	P.3-19
	Operation is too fast, causing the pen to lift.	Decrease [Draw Speed] in the cutting conditions.	P.3-19

Reciprocating cutter/Flat Blade Tool (only TUT)

Point to check	Cause	Corrective action	Reference page
B is not a cross	Cutter blade not centered	Check pattern B as described in "Center Adjustment."	P.3-23
Lines do not meet at A	[End Correct] value in cutting conditions too low	Increase the [End Correct] value.	P.3-20
	Cutter not centered	Perform [Center Adjust] in tool adjustment.	P.3-23
Lines of A are misaligned	Incorrect θ angle of Flat Blade Tool	Perform [Theta Angle Adjust] in tool adjustment.	P.3-31
Cutting is incomplete	Weak pressure	Increase [Cut/Draw Press] in the cutting conditions.	P.3-19
Cutting is incomplete at corners	[Start Correct] and [End Correct] values in cutting conditions too low	Increase the [Start Correct] and [End Correct] values.	P.3-20
D and D' are different lengths.	Cutter not centered	Perform [Center Adjust] in tool adjustment.	P.3-23
Too many incisions at C	[Start Correct] value too high	Decrease [Start Correct] in the cutting conditions.	P.3-20
	Cutter not centered	Check pattern A as described in [Center Adjust] in tool adjustment. Even with the same adjustment value, cutting depth varies by blade. Adjust to suit your application.	P.3-23

Crease tool (only TUT)

Point to check	Cause	Corrective action	Reference page
Lines do not meet at A	Cutter not centered	Perform [Center Adjust] in tool adjustment.	P.3-23
Lines of A are misaligned	Incorrect θ angle of crease tool	Perform [Theta Angle Adjust] in tool adjustment.	P.3-31
Creases are weak	Tool pressure is too low	Set [Zorg Offset] in the cutting conditions to [+].	P.3-19
	Weak pressure	Increase [Press Level] in the cutting conditions.	P.3-20
The cardboard flutes are crushed along the crease	The cutting conditions are not suitable for the work.	Review the cutting conditions.	P.3-19

Swivel cutter (standard unit only)

Point to check	Cause	Corrective action	Reference page
Lines are broken	Swivel cutter blade incorrectly mounted	Fully tighten the holder screw.	P.2-8
	Cutting is slow	Increase [Cut Speed] in the cutting conditions.	P.3-19
	Weak cutting pressure	Increase [Cut Press] in the cutting conditions.	P.3-19
Corners are rounded	Blade does not protrude enough	Increase the amount the blade protrudes.	P.2-8
	Offset value too small	Increase [Edge Offset] in the cutting conditions.	P.3-19

V-cut

V-cut test cut pattern

- One of two cutting patterns is automatically selected depending on the work thickness setting.

- (1) For a thickness of 0–10 mm
(Size on bottom of material cut: 45 x 75 mm)
- (2) For a thickness of 10–20 mm
(Size on bottom of material cut: 75 x 130 mm)

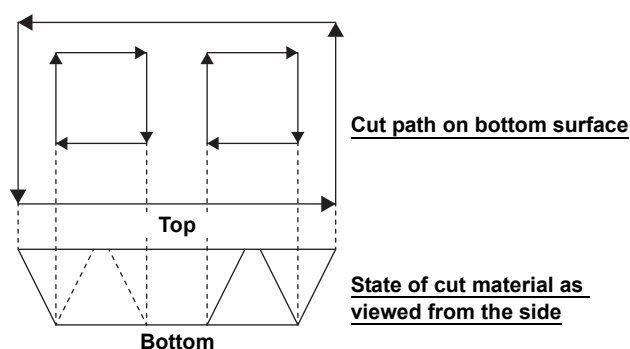

Router (only R10)

Router test cut pattern

- The pattern produced in test cutting includes both up-cuts and down-cuts. Select the cutting method that produces the cleanest cuts.
(Upcut/downcut settings are configured with FineCut/Coat9, which is included.)

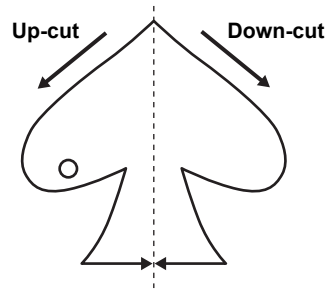

Point to check	Cause	Corrective action	Reference page
Uneven cut surfaces in both up-cuts and down-cuts	Cutting dust or debris on the blade (end mill)	Clean off debris or cutting dust on the blade (end mill).	P.7-9
	Blade (end mill) at end of service life	Replace the blade (end mill).	P.6-5
	Wrong blade (end mill) for the work	Replace with the correct blade (end mill) for the work.	P.6-16
	Wrong cutting conditions configured for blade (end mill) or work	Review the cutting conditions.	P.6-16

Checking Status Between Tools (Standard Unit, TUT)

Make a test cut to check the status between tools (pen and Flat Blade Tool, or pen and crease tool).

How to check

After drawing with the pen, perform test cutting with the Flat Blade Tool or crease tool at the same position to check the status between tools.

Corrective actions for 10 different cases, presented with samples, are described below.

Hint!

- Each mentions either one or multiple items for adjustment. Refer to the sample to identify which items require adjustment.
- These descriptions apply to the pen and flat blade tools. Flat Blade Tool information also applies to the crease tool.

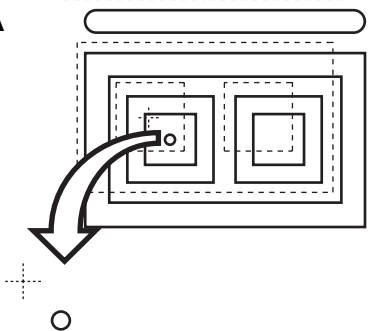
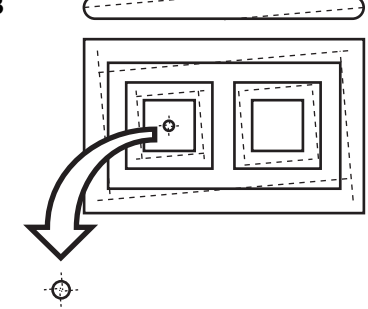
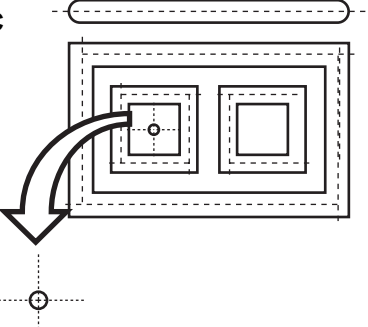
<p>Sample A</p> 	<p>Overview The Flat Blade Tool is misaligned with the center of the pen, regardless of the direction of movement.</p> <p>Corrective action Adjust offset as described in the tool adjustment information for cutter adjustment. (☞ P.3-28)</p>
<p>Sample B</p> 	<p>Overview Cutting is skewed clockwise (or counterclockwise).</p> <p>Corrective action Perform theta adjustment as described in the tool adjustment information for cutter adjustment. (☞ P.3-31)</p>
<p>Sample C</p> 	<p>Overview The starting point for cutting is too far forward (or back).</p> <p>Corrective action 1 Adjust [Start Correct] in the cutting conditions. (☞ P.3-20)</p> <p>Corrective action 2 Perform center adjustment using pattern A as described in the tool adjustment information for cutter adjustment. (☞ P.3-23)</p>

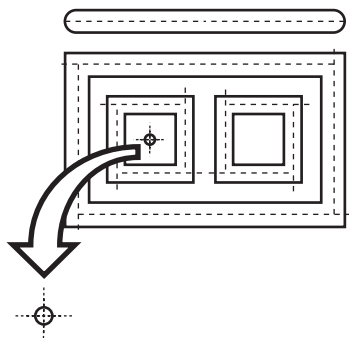
<p>Sample D</p> 	<p>Overview Cuts are too long (or short).</p>
	<p>Corrective action 1 Adjust [End Correct] in the cutting conditions. (☞ P.3-20)</p>
	<p>Corrective action 2 Perform center adjustment using pattern A as described in the tool adjustment information for cutter adjustment. (☞ P.3-23)</p>

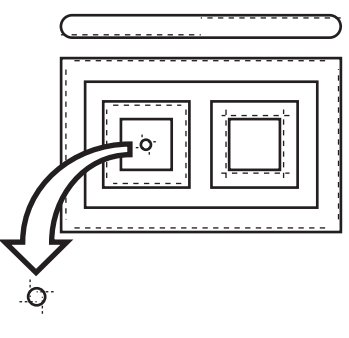
<p>Sample E</p> 	<p>Overview The Flat Blade Tool is misaligned to the right of the direction of movement.</p>
	<p>Corrective action 2 Perform center adjustment using pattern B as described in the tool adjustment information for cutter adjustment. (☞ P.3-23)</p>

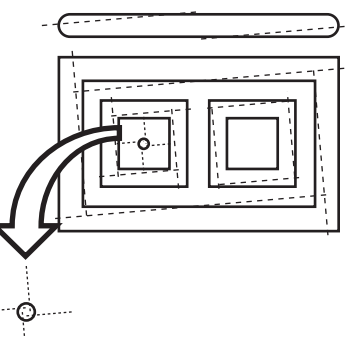
<p>Sample F</p> 	<p>Overview Cutting is skewed clockwise (or counterclockwise), and the starting point for cutting is too far forward (or back).</p>
	<p>Corrective action See corrective actions for samples B and C.</p>

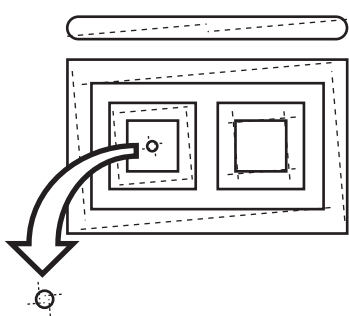
<p>Sample G</p> 	<p>Overview Cutting is skewed clockwise (or counterclockwise), and the Flat Blade Tool is misaligned to the right (or left).</p>
	<p>Corrective action See corrective actions for samples B and E.</p>

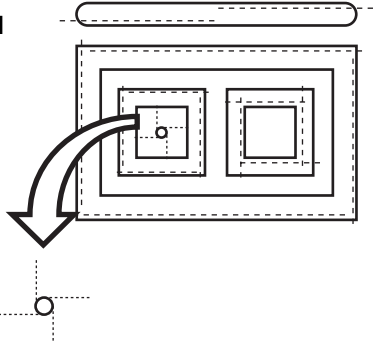
<p>Sample H</p> 	<p>Overview The starting point for cutting is too far forward (or back), and the Flat Blade Tool is misaligned to the right (or left).</p> <hr/> <p>Corrective action See corrective actions for samples C and E.</p>
--	---

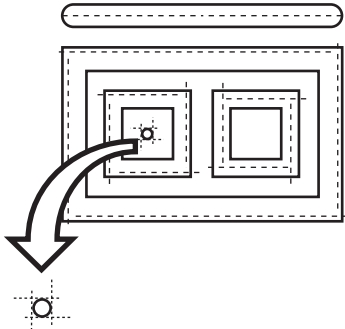
<p>Sample I</p> 	<p>Overview Cuts are too long (or short), and the Flat Blade Tool is misaligned to the right (or left).</p> <hr/> <p>Corrective action See corrective actions for samples D and E.</p>
--	--

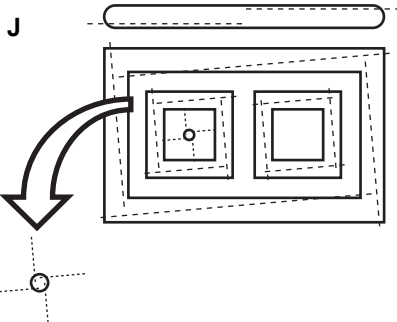
<p>Sample J</p> 	<p>Overview Cutting is skewed clockwise (or counterclockwise), cuts are too long (or short), and the Flat Blade Tool is misaligned to the right (or left).</p> <hr/> <p>Corrective action See corrective actions for samples B, D, and E.</p>
--	---

Setting the Drawing Origin

The drawing origin is the reference point for drawing, cutting, and creasing.

(It is normally set at the lower-right corner of the maximum effective cutting area.)

The drawing position moves as the origin is moved.

The drawing origin will be reset to the lower-right position when the following operations are performed:

- Turning off the power
- Resetting after an emergency stop (☞ P.1-16)

Hint!

- The drawing origin is at the coordinates (0, 0). When you move the head with the jog keys, the coordinates relative to the drawing origin are displayed.
- With the Sample Cut function, each shape is cut, creased, or drawn next to the drawing origin.

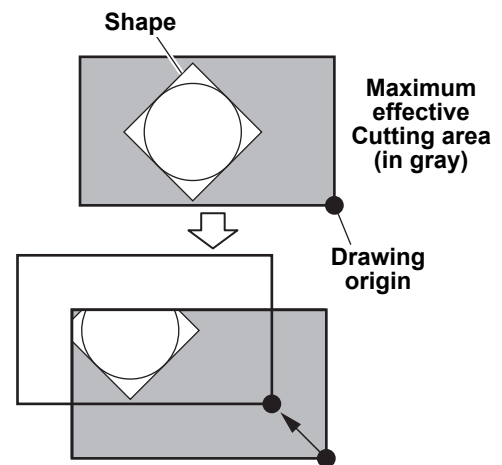

1 Press **▲▼◀▶** on the local mode screen.

- The [JOG Function Selects] screen is displayed.

2 Press **▲▼** to select [Plot Origin Setting], then press the [ENTER] key.

- The [Plot Origin Setting] screen appears.
- The head moves over the cutting panel, and the LED pointer is lit.

3 Press **▲▼◀▶** to move the LED pointer where you wish to set the origin.

- The head moves in each direction accordingly.
- The LED pointer XY coordinates are indicated on the operating panel.

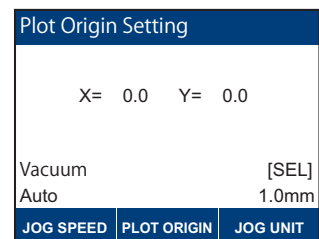

Hint!

- When set to toggle mode, the current area is displayed in the first row. Front Area/Rear Area/Standby Area

4 Press the [ENTER] key.

- The origin is set.
- The maximum drawing area is indicated.
- An error is displayed if the drawing origin is set in the positive direction from the upper-left point specified in the cutting area setting (☞ P.4-6). Complete this setting again.

Important!

- Some areas cannot be specified in toggle mode (an error is displayed). The origin cannot be set in the Y-bar retraction area. (☞ P.4-21)
- Setting the origin in the area at the rear changes the rear area origin.

Moving the Head to the Current Drawing Origin

1

Press [PLOT ORIGIN] on the [Plot Origin Setting] screen.

- The drawing origin coordinates are displayed.

2

Press the [ENTER] key.

- The head moves to the current drawing origin.

Hint!

- When set to toggle mode, the up and down keys can be used to select the drawing origin to be moved.

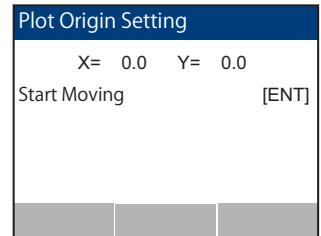
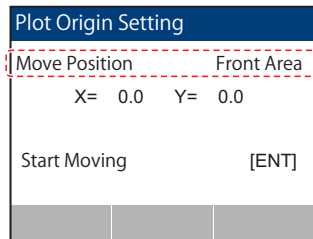

Effective Cutting Area

Maximum effective cutting area is listed below by model (with the figure showing the area for CFX-2513 models).

Model	X axis (mm)	Y axis (mm)
CFX-2513	1,300	2,540
CFX-2531	3,190	2,540
CFX-2550	5,080	2,540

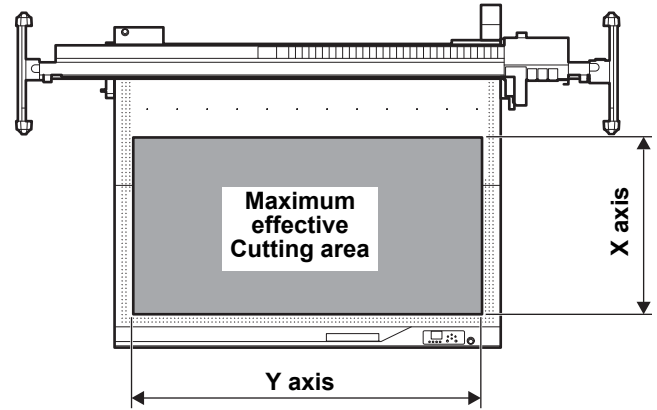

Important!

- In toggle mode, the effective drawing area in the X direction is limited to 1,250 mm for CFX-2531 models and 2,200 mm for CFX-2550 models.

Cutting or Drawing

1

After setting the drawing origin, press [REMOTE].

- The machine switches to remote mode.

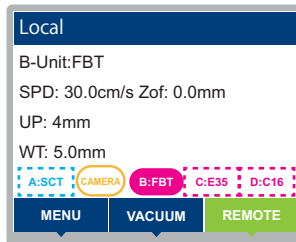

2

Send data from the host computer.

- Cutting begins automatically after the data is received.
- After cutting is finished, the following screen is displayed.

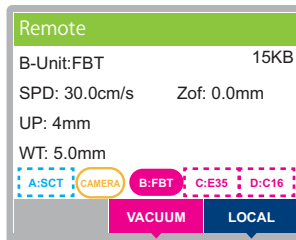

Interrupting Processing

To interrupt data processing during drawing, cutting, or creasing in remote mode, do the following.



- If cutting is interrupted, the cutting trace may be prominent at that point. Do not interrupt cutting unless absolutely necessary.

1

Press [LOCAL] during machine operation.

- Processing is interrupted, and the machine switches to local mode.

Resuming Processing

1

Press [REMOTE] to resume processing.

- The machine switches to remote mode and resumes processing.

Functions that can be set after interruption

● Clearing data in the receive buffer

 P.3-49 “Stopping Processing (Data Clear)”

Stopping Processing (Data Clear)

In the following cases, clear the received data from the receive buffer.

- (1) To clear a file for which you paused cutting (or drawing) from the receive buffer, without resuming processing
- (2) To clear data received but not yet processed from the receive buffer
- (3) To clear data remaining in the receive buffer before receiving data for use with the copying function
- (4) To cut using a different computer from the one that previously sent the cutting data

1 Access the local mode screen.

- When in remote mode, press [LOCAL] to enter local mode.
- Press [LOCAL] during data processing to interrupt processing.

2 Press the [SEL] key.

- The function of the [FUNCTION] key at the bottom of the screen is switched.

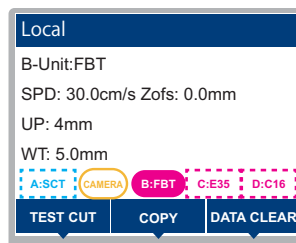

3 Press [DATA CLEAR].

- The confirmation window appears.

4 Press the [ENTER] key.

- The data is cleared.
- To cancel data clearing, press the [END/POWER] key. The machine returns to the screen of step 2.

Exiting toggle mode

1 After drawing in either area is finished or paused, clear the data.

- Important!** • Clearing the data discards both front and rear drawing data.

Restarting After Safety Sensor Detection

The machine will make an emergency stop if an obstruction is detected by the safety sensors when operating in remote mode.

A function is provided to allow operation to be resumed from recoverable data without having to cancel all of the cutting after operation stopped.

The subsequent operation will vary depending on the selected tool at the time the safety sensor detected an obstruction.

- For FBT, E12/E35/E60, C16/C26/C60/C6A, V45/VAS:
The machine switches to pause mode, and some line data will be discarded after the interruption, but subsequent operation can be continued.
- For R10:
The machine switches to local mode, and subsequent cutting data is discarded.
To complete cutting, cutting must be repeated using the same data.

Important!

- If the machine was stopped by pressing an emergency switch, all subsequent data is discarded.

Restart procedure after an emergency stop

1 Operation stops immediately if a light curtain is triggered while operating in remote mode.

2 If the obstruction remains, remove the obstruction, then press the [ENTER] key. If operation stops while the V cut tool is lowered, remove the V cut holder before pressing the [ENTER] key. (☞ P.1-17 “Removing the V-cut holder following an emergency stop”)

- Initialization starts.

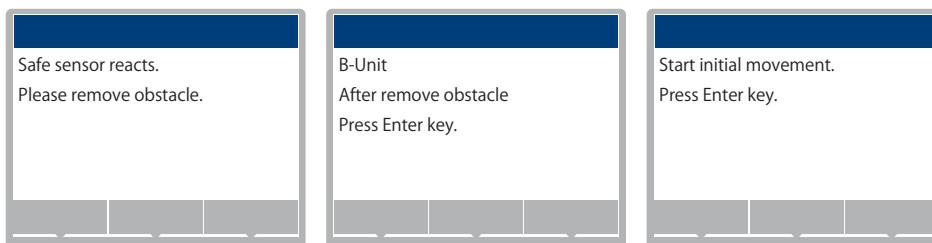

●For tools other than R10:

The machine switches to pause mode once initialization is complete. Press [REMOTE] to cut the subsequent data after the safety sensor stop.

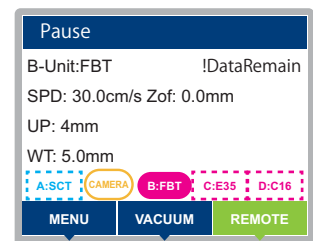

●For R10:

The machine switches to local mode once initialization is complete, and subsequent data is discarded.

To complete cutting, repeat cutting using the same data.

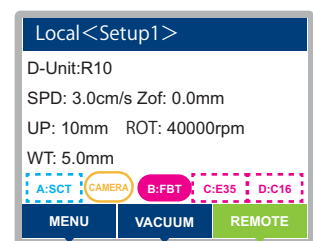

Power OFF

Before turning off the power, confirm that no data is being received, and that there is no data remaining to process.

1 Turn off the connected computer.

2 Hold down the [END/POWER] key to turn off the machine.

- A confirmation screen is displayed (press the [ENTER] key to turn off the machine).
- The [ENTER] key is no longer lit.

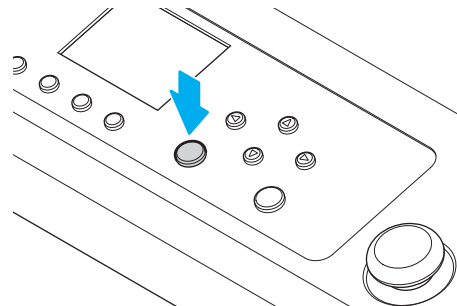

3 Set the main power supply switch on the right side of the machine to the “O” side.

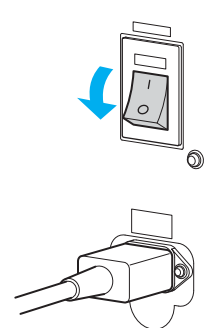

3

Checking for unprocessed data

To use the data for cutting	(1) Press [REMOTE] to switch to remote mode. (2) The amount of data received is displayed, and cutting (or drawing) begins.
To erase the data	(1) Press [LOCAL] to switch to local mode. (2) Clear the data (☞ P.3-49).

Chapter 4

Helpful Tips



About this chapter











This chapter describes operating procedures and settings for using the machine more conveniently.

Function Setting List	4-2	Setting the flat follow-up function	4-29
Jog Mode Functions.....	4-4	Setting the felt mat flatness	4-30
2-point Axis Correction	4-5	Setting Felt Mat Thickness	4-31
Cutting Area Settings	4-6	Set by measuring flatness	4-31
Moving the Head to a Corner of the Cutting Area	4-7	Entering values manually	4-33
Manual Cutting	4-8	Other Useful Functions	4-34
Aligning the Pointer Position	4-9	Setting Cutting Quality	4-34
Boot origin set	4-10	Setting the Speed of Head Movement	4-35
Assigning Pen Numbers	4-12	Setting an Offset for Adjusted Blade Pressure (Standard Unit)	4-36
Cutting the Same Data Again (Copy).....	4-13	Eliminating Pieces Left Uncut in Works (Standard Unit)	4-37
Changing the Cutting Order	4-14	Setting Up a Double Roller Effect	4-39
Setting Up Sorting	4-14	Setting the Display Language	4-40
Setting the Cutter Stroke.....	4-15	Setting the Display Unit	4-41
Dummy Cutting with a Swivel Cutter (Only Standard Unit).....	4-16	Setting the Key Buzzer	4-42
Setting the Close Time.....	4-17	Setting Startup Mode	4-43
Continuous Cutting	4-18	Setting Commands	4-44
Continuous Cutting Function (Continue Mode) . 4-18		Setting Computer Connection Conditions ..	4-46
Toggle Cutting (Toggle Mode)	4-18	Setting the Network	4-48
Setup	4-20	Copying Setting Values from Another User's Settings	4-50
Cutting	4-23	Restoring Default Settings	4-51
Restrictions in Continuous and Toggle Modes	4-27	Setting the Reciprocating Cutter Blade Position	4-52
Settings Initialized by Enabling/Disabling Continue Mode	4-27	Checking the Cutting Area in Advance	4-53
Flat Follow-Up Function	4-28	Switching Users	4-54
About the flat follow-up function	4-28	Checking Machine Information.....	4-55
		Updating the Machine Firmware	4-56

Function Setting List

This section outlines the various functions and describes their settings.

Function setting list

Function		Setting value	Default	Overview		
Drawing Settings	Cut Mode ( P.4-34)	Normal	Normal	Set the cutting quality.		
		Quality				
		Sharp				
		Fast				
	Vacuum Auto-On ( P.1-23)	Disable, Enable	Disable	Interlocks vacuum on/off with the remote key.		
	Vacuum Auto-Off ( P.1-23)	Disable, Enable	Disable	Turns off the vacuum after automatic retraction.		
	Auto View ( P.1-22)	OFF, lower right, lower left, upper right, upper left, middle right, middle left, drawing origin	OFF	Set the operation performed after drawing data is processed.		
Close Time ( P.4-17)	0 to 30 sec	3 sec	Set the wait time until performing operations executed after drawing data has been processed.			
Sorting ( P.4-14)	ON, OFF	OFF	Enables cutting sequence modification before cutting.			
Flat Follow-Up		FBT	ON, OFF	OFF	Set the function to cut according to the flatness of the felt mat, based on the measured flatness of the table.	
		C16/C26/C60/C6A				
		E12/E35/E60				
		V45/VAS				
		R10				
Command Settings	Command		MGL-3C	MGL-3C	—	
	Priority ( P.4-44)	SP, VS, AS, FS, ZF, ZA, ZO	Host, Panel	Host	Set which settings take priority if a setting item has been set differently on the machine and host computer.	
	OH:Response Value ( P.4-45)		Initial value, Setting value	Setting value	Set which value to return to the software after the machine receives a command to return effective area coordinates to the software.	
Copy Settings	Setup Copy ( P.4-50)		_____	_____	Copy setting values to the settings of another user.	
	Setup Reset ( P.4-51)		_____	_____	Reset the settings to defaults.	
Communication Settings	Network ( P.4-48)	IP Address	_____	_____	Shows the current IP address of the machine.	
		MAC Address	_____	_____	Shows the current MAC address of the machine.	
		DHCP	ON	ON	ON	Set to ON to use an IP address assigned by the DHCP server.
			OFF			
		AutoIP	ON	ON	ON	Set to ON to use an IP address set via the AutoIP protocol. Note that DHCP is given priority when DHCP is set to ON.
			OFF			
		IP Address* ¹	_____	_____	Set the IP address used by the machine.	
		Default Gateway* ¹	_____	_____	Set the default gateway used by the machine.	
DNS Address* ¹	_____	_____	Set the DNS server address used by the machine.			
Subnet Mask* ¹	_____	_____	Set the subnet mask digit number used by the machine.			

Function		Setting value	Default	Overview	
Communication Settings	RS-232C (☞ P.4-46)	Baud Rate	1200 to 38400 bps	38400 bps	
		Data Len	7, 8 bit	8 bit	
		Parity	None, Odd, Even	None	
		Stop Bits	1, 2	1	
		Handshake	X-PRM, None	None	
Machine Settings	Language (☞ P.4-40)		English, Japanese	English	Set the display language.
	Time Set		-20 to 0 to +4 h	_____	This can be set within the range of -20 to +4 hours.
	Unit: Length (☞ P.4-41)		mm, inch	mm	Select the length unit displayed for jog functions.
	Key Buzzer (☞ P.4-42)		ON, OFF	ON	Key sounds can be muted with this setting.
	Startup Mode (☞ P.4-43)		Local, Remote	Local	Set the mode that is active after the machine is turned on.
	TP Detect Setup (☞ P.5-10)		Sensor, Camera, Others	Sensor	Set when cutting data with register marks.
	Continue Mode		Disable/Continuous/ Toggle	Disable	Set to enable works to be switched and drawing operations to be executed continuously without using the operation panel. <ul style="list-style-type: none"> In toggle mode, the table is divided into two areas, front and rear, with each area set up for continuous drawing.
	Remote Control	Setting	Disable / Enable	Enable	Enabled to allow remote control by Mimaki Remote Access.
		PIN code	0000 to 9999	0000	Enter the same PIN code as used for MRA. The PIN code is used for authentication between the machine and MRA. <ul style="list-style-type: none"> Setting the machine to 0000 allows MRA to access the machine using any PIN code.
		KeyLife	5 min to 120 min	30min	Set the wait time before Mimaki Remote Access automatically terminates remote control if left idle during remote control.
	Select Vacuum		Front+Rear, Front, Rear	Front+Rear	Set the vacuum to be turned on or off. Displayed for CFX-2531 and CFX-2550 models only.
	Thickness Detect		Manual, Every time	Manual	Set whether work thickness is automatically detected each time or manually when drawing begins.
	Felt Mat Thickness (☞ P.4-31)		3.0 to 6.0 mm	4.2 mm	Set the felt mat thickness.
Reset		_____	_____	Resets the details set for "Setup", "Tool", "Communication Set", and "Machine Setup" to the original settings.	

*1: Available when both [DHCP] and [AutoIP] are set to OFF.

Jog Mode Functions

In local mode, press the ▲▼◀▶ jog keys to access the jog function selection menu, where the following settings are available.

Function	Details	Reference page
Plot Origin Setting	Set the cutting (drawing) start position.	P.3-45
Mark Origin Detection	The machine detects a register mark indicating the origin position.	P.5-15
Workpiece Thickness	Enter work thickness and adjust head height.	P.3-9
Underlay	Set whether or not underlay is used and its thickness.	P.3-6
2-point Axis Correction	Align vertical and horizontal axes of the machine with vertical and horizontal lines on loaded graph paper or the like.	P.4-5
Cutting Area Settings	Set the cutting (or drawing) range.	P.4-6
Manual Cutting	Cut works manually using jog keys.	P.4-8
Mark Offset	Perform offset adjustment to correct the register mark detection position.	P.5-17
Camera Adjustment	Use the camera app to make adjustments when an optional camera unit is installed.	P.5-13
Boot origin set	Saves the starting position for cut (drawing) at startup.	P.4-10
Move to View Pos.	The head can be moved directly to any corner of the table or to the drawing origin.	P.3-4
Pointer Offset	Adjust the offset between the LED pointer and tool.	P.4-9
Change jog speed	Change the jog speed. (In jog mode, press the [JOG/SPEED] key.) Each press of the [JOG SPEED] key switches the speed. (Auto → Low → Middle → High)	–
Change unit of jog movement	Set the amount of movement when the head is moved with the jog keys. (In jog mode, press the [JOG/UNIT] key.) Each press of the [JOG UNIT] key switches the amount of movement. • Default: 1.0 mm (1/16 inch) • Setting values: For mm: 0.1 mm, 1.0 mm • Setting values: For inch: 1/16 inch, 1/160 inch	–
View	Jog mode used when there is drawing data.	–



- When positions such as the origin are specified in jog mode, the center of the LED pointer is set to the specified position.
- In jog mode, pressing the [SEL] key turns vacuum operation on and off.

2-point Axis Correction

Align vertical and horizontal axes of the machine with vertical and horizontal lines on loaded graph paper or the like.

The specified drawing origin and correction point are used to correct axis tilt (θ).

The correction angle will be cleared when the following operations are performed:

- Resetting the drawing origin
- Specifying the drawing origin at the correction point
- Turning off the power
- Resetting after an emergency stop (☞ P.1-16)

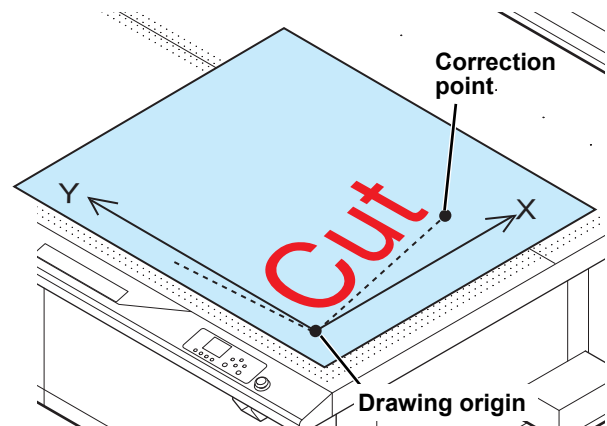

1

Load a ruled work.

2

Set the drawing origin (☞ P.3-45).

3

Press \blacktriangle \blacktriangledown \blacktriangleleft \blacktriangleright on the local mode screen.

- The [JOG Function Selects] screen is displayed.

4

Press \blacktriangle \blacktriangledown to select [2point Axis Correction], then press the [ENTER] key.

- The [2point Axis Correction] screen appears.
- The head moves over the cutting panel, and the LED pointer is lit.

5

Press \blacktriangle \blacktriangledown \blacktriangleleft \blacktriangleright to move the LED pointer to the correction point.

- The head moves in each direction accordingly.
- The LED pointer XY coordinates are indicated on the operating panel.

6

Press the [ENTER] key to confirm the correction point.

- The correction angle ($\theta = -45^\circ$ to 45°) is displayed.
- If out of range, an error is displayed. Complete the correction again.

4

Cutting Area Settings

The cutting area is set covering an area from the drawing origin to the upper left (UL) point that you set. Set the UL point position here.

The cutting area will be cleared when the following operations are performed:

- Turning off the power
- Resetting after an emergency stop (☞ P.1-16)

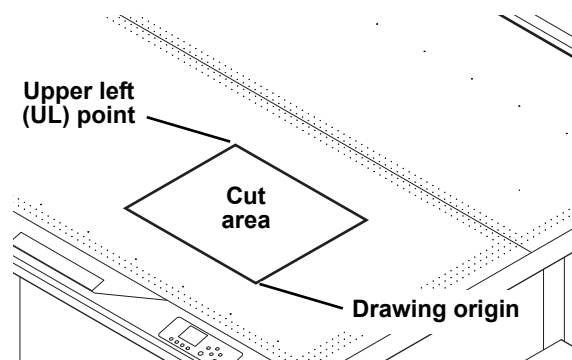

1 Press **▲▼◀▶** on the local mode screen.

- The [JOG Function Selects] screen is displayed.

2 Press **▲▼** to select [Cut Area], then press the [ENTER] key.

- The [Cut Area] screen appears.
- The head moves over the cutting panel, and the LED pointer is lit.

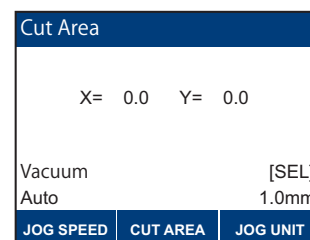

3 Press **▲▼◀▶** to move the LED pointer to the point in the upper left.

- The head moves in each direction accordingly.
- The LED pointer XY coordinates are indicated on the operating panel.

4 Press the [ENTER] key.

- The maximum drawing area is indicated.

Important!

- Set the UL point in the positive direction from the origin.
- Set the origin within the cutting area. An error will occur if it is set outside the cutting area.

Important!

- The cutting area has no effect in toggle mode.

Moving the Head to a Corner of the Cutting Area

1

On the [Cut Area] screen, press the [CUT AREA] key.

2

Press ▲ ▼ to select the destination.

- Setting values: Upper left, upper right, lower left, lower right
- Destination coordinates are indicated for the setting value.

Cut Area	
Move Position	Upper Left
X= 1300.0	Y= 2540.0
Start Moving	[ENT]

3

Press the [ENTER] key.

- The head moves to the specified position.

Manual Cutting

With the tool lowered, use jog keys to move the head. This enables work cutting.

Important!

- Manual cutting is only available with certain tools. If it is not available, an error is displayed.
Compatible tools
Flat blade tool (FBT), reciprocating cutter (E12, E35, E60)

1

Set up the work to cut and set the work thickness (☞ P.3-9).

2

Mount the cutting tool and select it in [Tool] > [Tool Select] (☞ P.3-17).

- If [Cutting Edge Detection] has not been performed, do it in advance. (☞ P.3-14)

3

Press ▲▼◀▶ on the local mode screen.

- The [JOG Function Selects] screen is displayed.

4

Press ▲▼ to select [Manual Cut], then press the [ENTER] key.

- The [Manual Cut] screen appears.
- The head moves over the cutting panel.
- The selected tool is lowered to the raised position.
- The coordinates indicated are the XY position of the selected tool.

5

Press ▲▼◀▶ to move the tool.

- The head moves in each direction accordingly.
- The [F1: JOG SPEED] key can be used to change the JOG speed.
(The [F1: JOG SPEED] key is supported from firmware version 1.8.0.)

Setting value	Overview	
Setting	Cut speed and up speed set in the tool settings	
Low	Low speed	Cut speed and up speed are the same value
Middle	Medium speed	
High	High speed	

- The [F2: ZUP / ZDOWN] key can be used change UP and DOWN of tool.
- The [F3: JOG UNIT] key can be used to switch the travel (0.1 mm ⇔ 1.0 mm).

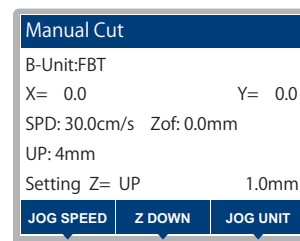

6

When finished, press the [END/POWER] key.

- The tool is fully raised.

Aligning the Pointer Position

Adjust the alignment of the pen tip and LED pointer position.

Draw an adjustment pattern with the pen, then adjust by using JOG operations to match the positions.

Important!

- Mount the pen on the standard unit.

1 Set up the work and set the work thickness to draw the adjustment pattern (☞ P.3-9).

2 Press     on the local mode screen.

- The [JOG Function Selects] screen is displayed.

3 Press   to select [Pointer Offset], then press the [ENTER] key.

- The drawing start standby screen appears.

4 Press the [ENTER] key to start drawing.

- A cross pattern is drawn.
- Once drawing is complete, the LED pointer lights up and moves to the intersection of the cross drawn.

5 Press     to align the LED pointer with the intersection of the cross drawn.

- The head moves in each direction accordingly.
- The LED pointer XY coordinates are indicated on the operating panel.

6 Once aligned with the intersection, press the [ENTER] key.

- The aligned value is displayed for a few seconds, then the menu is exited.
-

Boot origin set

The boot origin is normally the lower-right drawing start position. However, if the origin position has been changed using Boot origin set, the changed origin position becomes the boot origin. The drawing start position after recovering from an emergency stop is the boot origin.

It can be set to any position within the maximum effective cutting area. Even if the power is turned off, drawing will resume from the set position upon the next startup.

The setting is cleared and the drawing origin returns to the lower-right position when the following operation is performed.

- Resets origin upon boot

The setting is not cleared when the following operation is performed:

- When the power is turned off
- When recovering from an emergency stop → (P.1-12)

Hint!

- When performing the Boot origin set, the position where the origin is set becomes the drawing origin at the coordinates (0, 0).
- If the message “Do you want to save” is displayed, the setting will not be applied unless pressing the [ENTER] key.

1

On the local mode screen, press **▲▼◀▶** key.

- The [JOG Function Selects] screen is displayed.

2

Press **▲▼** key to select [Boot origin set], then press the [ENTER] key.

- The [Boot origin set] screen is displayed.

3

Select [Boot origin set], then press the [ENTER] key.

- The head moves over the cutting panel, and the LED pointer is lit.

4

Press **▲▼◀▶** key and move the light pointer to the position for saving the origin.

- The head moves in each direction accordingly.
- The LED pointer XY coordinates are indicated on the operating panel.

Hint!

- If you adjust the jog speed or unit of jog movement, display in the area outlined in red below is updated accordingly. For adjustment instructions, see ( P.4-4) .

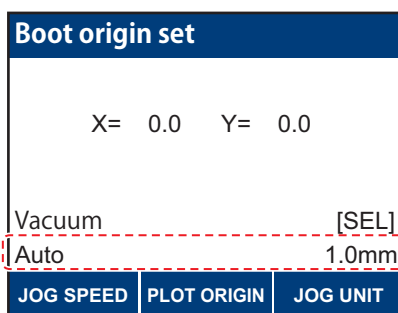

5**Press the [ENTER] key**

- The maximum drawing area is indicated.
- A message “Do you want to save” is displayed.

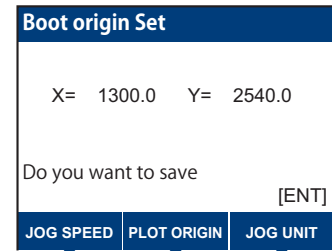
**6****Press the [ENTER] key.**

- After execution, return to the local mode.

重要!

- If continuous mode or toggle mode is enabled, a warning message will indicate and the operation cannot be performed.
- When the drawing origin is stored and the power is turned on with continuous mode or toggle mode enabled, the drawing origin at startup will be positioned at the lower-right corner.

Restoring Default Settings

1**On the local mode screen, press \blacktriangle \blacktriangledown \blacktriangleleft \blacktriangleright key.**

- The [JOG Function Selects] screen is displayed.

2**Press \blacktriangle \blacktriangledown key to select [Boot origin set] > [Reset boot origin], then press the [ENTER] key.****3****Press [RESET].**

- Reset boot origin is executed.
- After execution, return to the local mode.
- To cancel execution, press the [END/POWER] key.

Assigning Pen Numbers

Set up assignment of tools on the machine corresponding to pen numbers in data.
Up to eight pens can be assigned to tools on the machine.

This example shows how to configure the following settings.

Pen 1 (pen number in drawing data) → Set to pen

Pen 2 (pen number in cutting data) → Set to reciprocating cutter

With these settings, Pen 1 and Pen 2 data can be drawn and cut at the same time.

1 On the local mode screen, press [MENU].

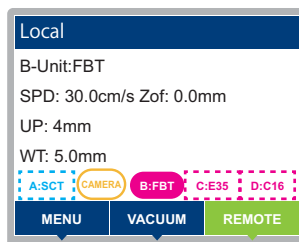

2 Press ▲ ▼ to select [Tool] > [Tool Setting], then press the [ENTER] key.

3 Press ▲ ▼ to select [Pen Allocation], then press the [ENTER] key.

- The current tool name is indicated.

4 Press ▲ ▼ to select a pen number to assign, then press the [ENTER] key.

- In this example, [PEN No. 1] is selected.
- Setting values: PEN No. 1 to 8

5 Press ▲ ▼ to select the combination of units and tools.

- Setting values vary depending on the tools mounted.

Unit	Tool	Max. no. of groups saved
A	SCT	1
A	PEN	1
B, C, D	FBT	3
B, C	E12/E35/E60	2
B, C, D	C16/C26/C60/C6A	3
B, C, D	V45/VAS	3
D	R10	1

6 Press the [ENTER] key.

- To set other pen numbers, repeat steps 2 to 4.

7 To exit, press the [END/POWER] key several times to return to the local mode screen.

Cutting the Same Data Again (Copy)

Previously cut data can be cut again while offline (local mode) .
This eliminates the need to send the same data repeatedly from the computer.

Important!

- Copying is not available when continuous mode is enabled.

1

Cut once using the data that you will make copies with (☞ P.3-49).

- Only one data item can be stored in the receive buffer.
- Any new data received overwrites existing data. (Copying is not available for multiple items, or by specifying items that were previously received.)

2

Press [LOCAL] to switch to local mode.

3

Set the drawing origin (☞ P.3-45).

- Reset the origin to the position for copying. If the origin is not reset, cutting will be performed in the same place.

4

On the local mode screen, press the [SEL] key.

- The function of the [FUNCTION] key at the bottom of the screen is switched.

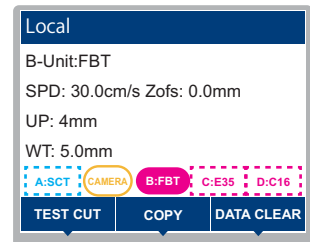

5

Press [COPY].

- Copying cannot begin unless cutting data has been received since startup.

6

Press the [ENTER] key to start copying.

- To exit without copying, press the [END/POWER] key.
- To switch to remote mode and start cutting (or drawing), press the [ENTER] key.
- After copying, the machine switches to local mode.
Head retraction follows the setting in [MENU] > [Setting] > [Draw] > [Auto View]. (☞ P.1-22)
- To cut again, follow these instructions from step 3.

4

Changing the Cutting Order

Cutting data sent from the host computer can be rearranged to cut in a different order. (This utilizes the sorting function.)

If the order of data sent from software prevents data from being cut efficiently, the sequence of cutting can be changed to streamline cutting.

Some software sends data in the order in which the data was created or edited.

- This prevents efficient cutting if scanned data has been modified, for example, because modified portions will be cut at the end.

To cut after sorting

Sorting enables cutting in individual blocks, where one block corresponds to movement with the pen down to raising the pen. Once one block has been cut, the block with the nearest origin position is then cut.

The host data start point and cutting direction are not changed.

● marks: Data starting point, equivalent to the cutting starting point

Arrows: Data direction, equivalent to the cutting direction

Number: Block cutting order

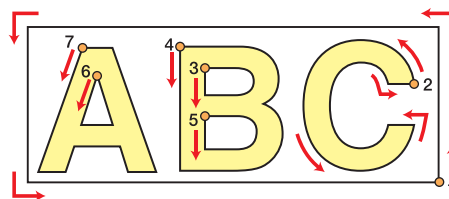

Setting Up Sorting

- 1 On the local mode screen, press [MENU].

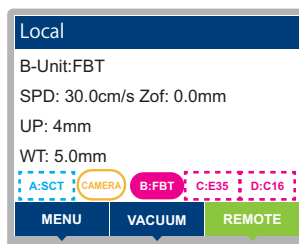

- 2 Press ▲ ▼ to select [Setting] > [Draw] > [Sorting], then press the [ENTER] key.

- 3 Press ▲ ▼ to select the setting.
 - Setting values: ON, OFF

- 4 Press the [ENTER] key.
 - To exit without saving, press the [END/POWER] key.

- 5 To exit, press the [END/POWER] key several times to return to the local mode screen.



- Changing the setting value will clear the receive buffer.
- Enabling sorting reduces the receive buffer size to approximately 16 MB.

Setting the Cutter Stroke

The machine can be set to move a shorter distance to raise the tool when cutting (or drawing) data with many up/down movements of the tangential cutter or crease roller. This reduces the total cutting time.



- When using a work holder, set a value larger than the length between the blade tip and the pressure face of the work holder. If this is too small, the work holder will rub against the work surface when raised and moved.

1

On the local mode screen, press [MENU].

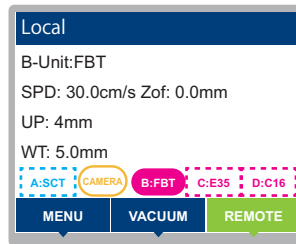

2

Press ▲ ▼ to select [Tool] > [Tool Setting], then press the [ENTER] key.

3

Press ▲ ▼ to select the tool.

- For units with many available tools, use << >> to switch screens.
- Configurable tools vary by unit. (☞ Unit and Tool Combinations)

Important!

- Regardless of the tools actually mounted, tool settings for each unit can be configured.
- Tool settings are saved on a per-unit basis. They are not applied to other units.

4

Press the [ENTER] key.

- The settings are saved.
- To exit without saving, press the [END/POWER] key.

5

Press ▲ ▼ to select the [Up Height] setting to configure, then press the [ENTER] key.

- Items displayed vary by tool. (☞ "Setting items")

6

Press ▲ ▼ to select the setting value.

- Setting values: 2 to 40mm, Fullup

7

Press the [ENTER] key.

- The settings are saved.
- To exit without saving, press the [END/POWER] key.

Dummy Cutting with a Swivel Cutter (Only Standard Unit)

The machine can be set to perform dummy cutting if data is received when a swivel cutter is selected at the start of cutting.

- After the initial dummy cutting, dummy cutting is not performed again when the next data is cut (until the power is turned off).
- Unless dummy cutting has been performed already, dummy cutting is performed when the tool is switched to a swivel cutter during cutting.
- Safety sensor activation resets the dummy cutting state, and dummy cutting is performed the next time the conditions for it are met.
- Dummy cutting is not performed unless the corresponding setting in the tool settings is set to ON.
- The dummy cut is made in the following position: 1 mm next to the origin, 1 mm in the negative Y direction, and 10 mm in the positive X direction.

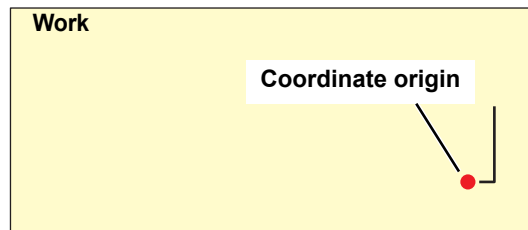

1 On the local mode screen, press [MENU].

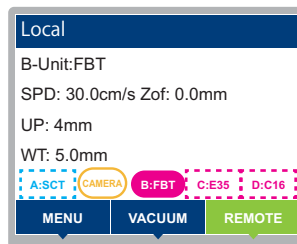

2 Press \triangle ∇ to select [Tool] > [Tool Setting], then press the [ENTER] key.

3 Press \triangle ∇ to select [A-Unit] > [A-Unit:SCT], then press the [ENTER] key.

- For units with many available tools, use \ll \gg to switch screens.
- Configurable tools vary by unit. (Unit and Tool Combinations)

Important!

- Regardless of the tools actually mounted, tool settings for each unit can be configured.
- Tool settings are saved on a per-unit basis. They are not applied to other units.

4 Press \triangle ∇ to select [Dummy Cut], then press the [ENTER] key.

5 Press \triangle ∇ to select the setting value.

- Setting values: OFF, ON

6 Press the [ENTER] key.

- The settings are saved.
- To exit without saving, press the [END/POWER] key.

Setting the Close Time

After data sent from a computer is cut (or drawn), the following operations are automatically performed at a preset time.

- Auto head retraction (👉 P.1-22)
- Vacuum off (👉 P.1-25)

1 On the local mode screen, press [MENU].

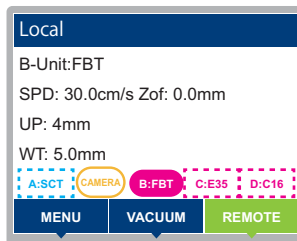

2 Press ▲ ▼ to select [Setup] > [Draw] > [Close Time], then press the [ENTER] key.

3 Press ▲ ▼ to select the setting.

- Setting values: 0 to 30 sec

4 Press the [ENTER] key.

- To exit without saving, press the [END/POWER] key.

5 To exit, press the [END/POWER] key several times to return to the local mode screen.

Continuous Cutting Function (Continue Mode)

Continue Mode enables continuous work switching and drawing operations without using the operation panel. After drawing data is sent to the machine, simply replacing a work (turning on the vacuum) after one drawing is finished automatically starts the next drawing (when the data setting is [Copy] or [ID linkage]).



- In continuous mode, no distinction is made between front and rear areas, and the entire drawing area is used.
- Toggle cutting is available when an optional extended table is connected.



- Output the data via Ethernet when using continue mode.

Toggle Cutting (Toggle Mode)

In toggle mode, the table is divided into two areas, front and rear, with each area set up for continuous drawing. Another work can be set up in the rear area during drawing in the front area, which saves time for replacement during drawing.

Toggle cutting (toggle mode) is available on CFX-2531 and CFX-2550 models.



- When using the toggle unit for toggle cutting with a single CFX-2531 vacuum unit, the suction force varies depending on whether the front and rear are suctioned separately or simultaneously. Therefore, if the work is held down by suction on one of the tables during cutting, the suction force holding the work will decrease. When using the toggle cutting function, ensure that the work remains securely held and can be processed safely, even if the suction force changes (decreases) during cutting.
- The cooling fan on the back of the equipment may continue to run for about ten minutes after the vacuum stops. This is normal and not a malfunction. This allows the internal temperature of the equipment to cool properly. Please wait until it stops.
- While using the vacuum, make sure the cooling fan on the back of the equipment is running properly. If the fan does not run while the vacuum is operating, the equipment may be malfunctioning. Discontinue use immediately.



- In toggle mode, the effective drawing area in the X direction is limited to 1,250 mm for CFX-2531 models and 2,200 mm for CFX-2550 models.
- Disabling continuous mode also disables toggle mode.
- Disabling continuous mode discards data received up to that point.
- The toggle cut function requires the foot switch option (sold separately). Please purchase according to your machine size. (A foot switch is standard with the 2531 and 2550 models.)

Note: Figure applies to CFX-2531

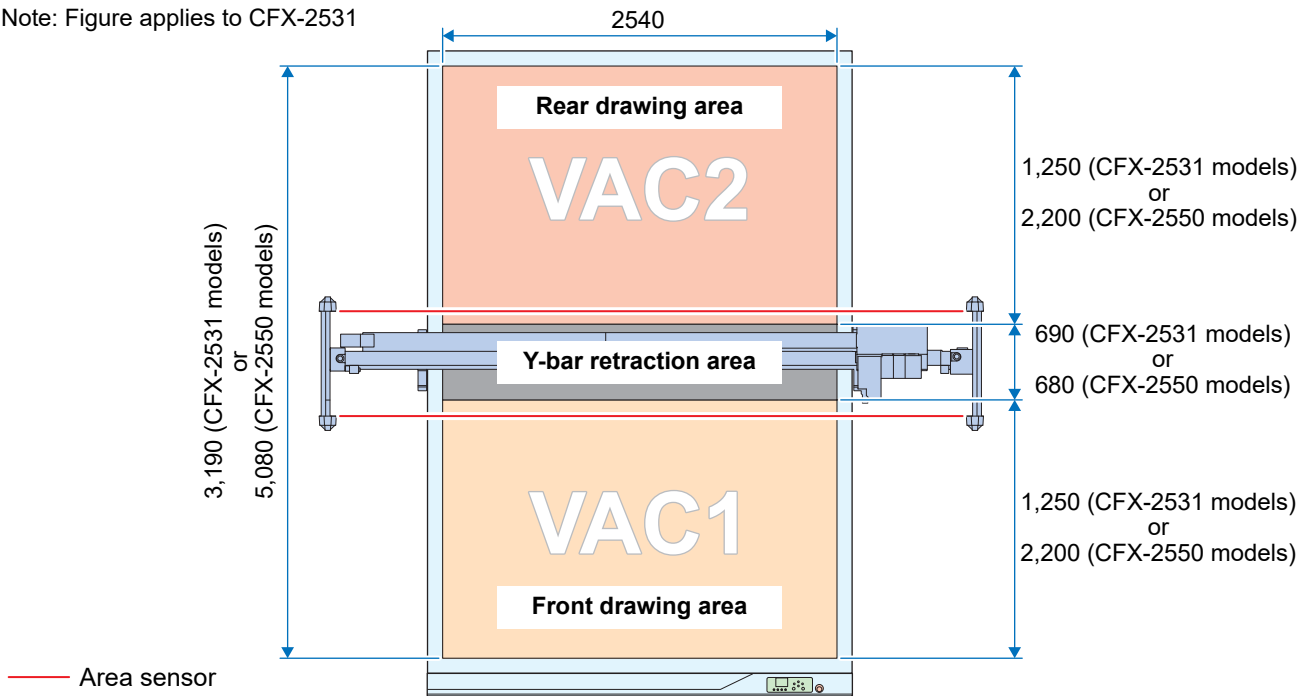

Hint!

- Toggle cutting (toggle mode) is available on CFX-2531 and CFX-2550 models.
- * **Toggle mode cannot be selected for the following:**
 - CFX-2513 models
 - CFX-2531 models that use a 7.5 kW vacuum and do not use a toggle unit
- **The toggle function is not available when using a CFX-2531 model with one vacuum unit without a toggle unit.**

Setup

Configure the settings for continuous and toggle modes, and for the origin.

Mode settings

1 On the local mode screen, press [MENU].

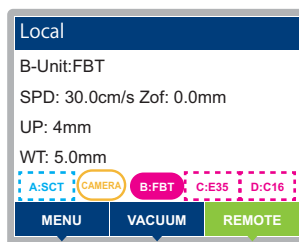

2 Press \triangle ∇ to select [Machine Setup] > [Continue Mode Setting] > [Continue Mode], then press the [ENTER] key.

Hint! • The [Continue Mode] menu is not displayed unless all data sent to the machine has been drawn.

3 Press \triangle ∇ to select [SET CONF], then press the [ENTER] key.

- Setting value: Disable/Continue/Toggle
- Setting to Continue enables continue mode.
- Setting to Toggle enables toggle mode.

Hint! • Toggle mode cannot be selected on models that do not support the toggle cut function (toggle mode), or when an extended table is connected.

4 Press ▲ ▼ to select [Front Area Setting], then press the [ENTER] key.

- Set [Cut data], [Thickness], and [Type of ID'd Mark].

Item	Overview	Options	Useful for	Notes
Cut data	Specify how data is prepared for continuous mode	Copy	When using the same data	Data received at one time is reused.
		Receiving	When you will change the drawing data each time	The data received is used for drawing. Data must be sent each time.
		ID linkage	Low-volume production of multiple drawing data files, etc.	When a data ID code is printed on the work, the code is read to receive data from the server. <ul style="list-style-type: none"> • Requires ID codes to be printed.
Thickness	Selects numerical input or measurement	Numerical input	<ul style="list-style-type: none"> • When you wish to save time • When drawing on works of the same thickness 	Work thickness can be set in a range of 0.1 mm to 54.0 mm. Each time, drawing is performed for the specified work thickness. <ul style="list-style-type: none"> • Work thickness is not measured.
		Measure	When using works of various thicknesses for drawing	Work thickness is measured before cutting begins. Pen caps must be installed (SCT and PEN cannot be used for drawing in this mode). <ul style="list-style-type: none"> • Work thickness is measured each time, which takes more time overall than numerical input.
Type of ID'd Mark	Only when data mode is set to ID linkage	Type.1	-	Multiple types of shapes cannot be set. When assigning IDs, use the same mark form. (P.5-2)
		Type.2		
		Type.3		

Important!

- When using data with an ID for cutting in continuous mode, be sure to enable [ID linkage].

Hint!

- In toggle mode, different [Cut data], [Thickness], and [Type of ID'd Mark] settings can be set for the front and rear areas.
- For CFX-2513 models, rear area settings are not displayed in the menu.

5 When using toggle mode, set the origin mode.

- Default: FR method
- FF method:
The rear area origin is set to the lower right of the rear area. The coordinate system is oriented the same way as for the front area.
- FR method:
The rear area origin is set to the upper left. The coordinate system is rotated 180°.

Hint!

- For CFX-2513 models, not displayed in the menu.

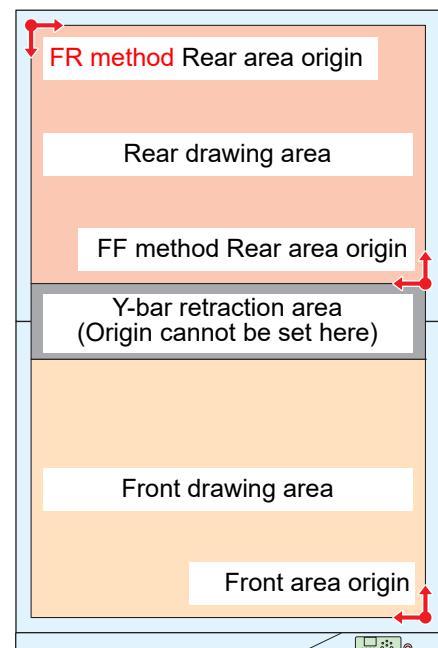

Setting the origin

Set the origin in the jog origin setup. Each drawing starts from the same origin.

- In toggle mode, different origins can be set for the front and rear areas.
- In toggle mode, the origin for the front drawing is set if the position where the origin is set lies within the front drawing area. If it is in the rear drawing area, the origin for the rear drawing is set. The same applies when the origin is set using [Mark Origin Detection].
- The origin cannot be set in the Y-bar retraction area (see the figure below).

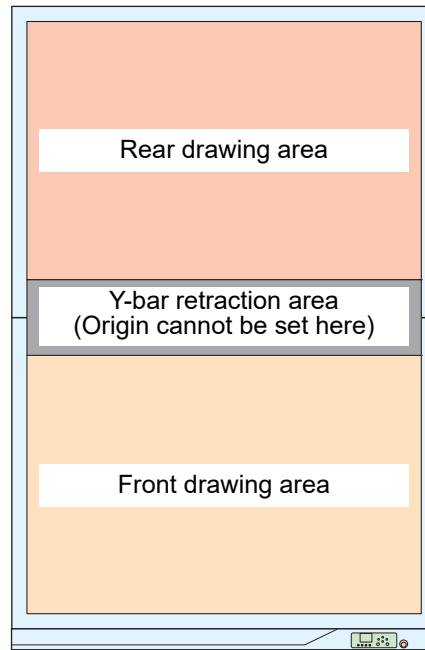

Important!

- Cutting area settings have no effect in toggle mode.

Cutting

In continuous mode

1 Press the [REMOTE] key.

- The machine switches to remote mode.

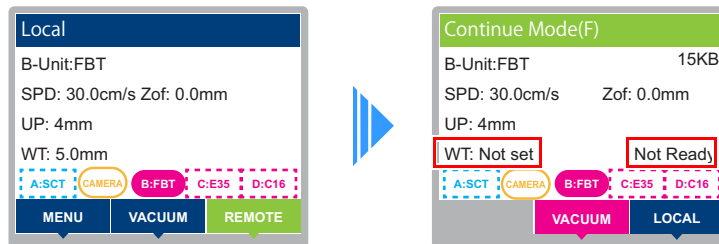

Hint!

- When continuous mode is enabled, the machine can switch to remote mode even if work thickness is not detected. At that time, work thickness is indicated as the work thickness setting value or as [Not set]. (The actual value is applied after work thickness is measured.)
- When continuous mode is enabled, the title of the remote mode screen changes from [Remote] to [Continue Mode(F)].
- The current state of the effective area is displayed at the lower right of the panel. (☞ P.1-13)

2 Set up the work and turn on the vacuum.

Important!

- When [Work Thickness] is set to [Measure], work thickness is measured at the origin. Be sure to set the origin within the work area. Failure to measure work thickness may cause the tool tip to come into contact with the work, which may damage it.

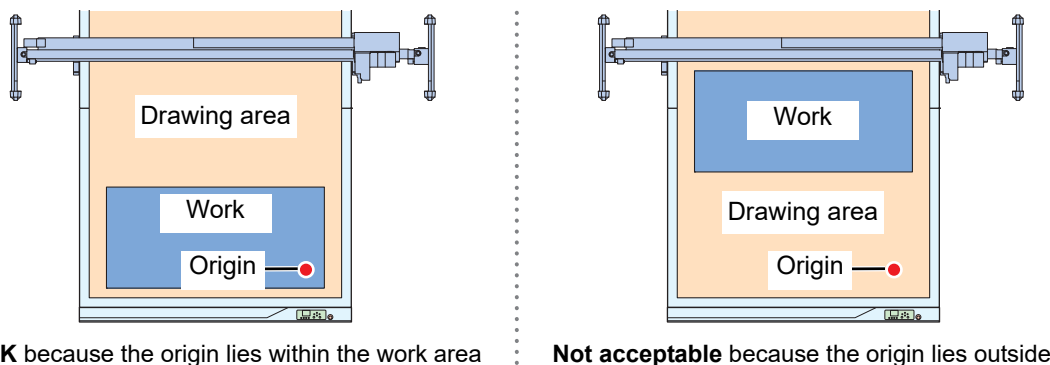

Hint!

- Vacuum can be turned on either by using the panel or a foot switch.
- The origin can be set anywhere in the drawing area.

● When the data setting is [ID linkage]

- Register mark and data ID code detection is performed relative to the specified origin.
- If the work thickness setting is set to [Measure], work thickness is detected before mark detection.
- After successful detection of the data ID, data is received from the cutting link and drawing begins.
- If data ID code detection fails, an error is displayed.

Important!

- If data cannot be received for a certain period after data ID code detection, an error is displayed.
- If set to [ID linkage], disable the data ID code setting in TP Detect Setup. (☞ P.5-10)

● When the data setting is [Copy] or [Receiving]

3

Send data from the host computer.

- Once the data is received, the head moves to the origin.
- If the work thickness setting is set to [Measure], work thickness is detected.

Hint!

- Step 3 can be done before step 2 if you prefer.
-

4

Collect the work after cutting is finished.

- The head is retracted when cutting is finished.

Hint!

- Once retraction is complete, the vacuum is forcibly turned off for the cut area.

Important!

- Software settings for automatic head retraction or other functions that move the head to a predetermined position after drawing cannot be used. If the software requests head retraction, the head moves to the position indicated by the software and then to the retraction position.
-

5

Set up the new work before turning on the vacuum.

- Repeat steps 2 to 4.
 - If the cutting data was set up for copying, there is no need to send the data again.
 - Turning the vacuum ON immediately moves the head to the origin, followed by work thickness measurement (when the work thickness setting is set to [Measure]) and drawing operations.
-

6

Pause operation as needed.

- To pause drawing, press the [LOCAL] key.
 - To resume operation, press the [REMOTE] key again.
-

7

Exit continuous mode when finished.

- To exit continuous mode, clear the data after the drawing is finished or while operation is paused.
-

8

Use new data for drawing, as needed.

- To prepare new drawing data, clear the data and start over from the beginning.
-

In toggle mode

Drawing in the front area and then the rear area is performed as follows.

- Hint!** • The order of areas used for drawing can be reversed.

1 Press the [REMOTE] key.

- The title changes to [Continue Mode(F)] or [Continue Mode(R)].
- [Continue Mode(F)] indicates that the front (front side) area is active and [Continue Mode(R)] that the rear area is active.

- Hint!** • The active area during standby is set to the area for which the vacuum was last turned on.
Example: When [Continue Mode(F)] is displayed, turning on the rear area vacuum (Vacuum 2) changes the mode to [Continue Mode(R)].

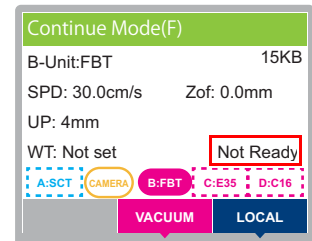

- Important!** • The active area is not changed during drawing.
• The rear area vacuum should be turned on with a foot switch.

2 Set up a work and turn on the front area vacuum.

- The front area with the vacuum turned on becomes active.

● When the data setting is [ID linkage]

- As in continuous mode, the head moves to the origin and detects marks and data ID codes.
- If the work thickness setting is set to [Measure], work thickness is detected before mark detection.
- After successful detection of the data ID, data is received from the cutting link and drawing begins.
- If data ID code detection fails, an error is displayed in the same way as for continue mode.

● When the data setting is [Copy] or [Receiving]

3 As in continuous mode, data is received from the host computer, and then drawing operations are performed.

- Once the data is received, the head moves to the origin.
- If the work thickness setting is set to [Measure], work thickness is detected.

- Important!** • Data cannot be received while drawing is in progress or paused. Wait until drawing is finished.
• Drawing will not start if the vacuum was turned off before the data was received. Turn on the vacuum.

4 Collect the work after cutting is finished.

- The head is retracted when cutting is finished.

- Hint!** • When toggle mode is enabled, the retraction position is in the center of the retraction area.
• The vacuum for the area used for cutting will be forcibly turned off after retraction regardless of the Vacuum Auto-Off setting.

- Important!** • Whether or not the vacuum is on is used to determine whether the uncut area is ready.
Example: If the work is ready (vacuum is on) in the rear area when cutting in the front area is finished, the active area switches to the rear area (from [Continue Mode(F)] to [Continue Mode(R)]). Cutting starts if there is active data in the rear area.

● When the rear area work is ready

5

As with the front area, after data is sent, drawing on the rear area begins.

- If the rear area data setting was [ID linkage], the head moves to the origin, measures work thickness, and detects the data ID.

Important!

- Before rear area drawing data is sent, make sure the panel display is [Continue Mode(R)]. If data is sent while [Continue Mode(F)] is shown, front area drawing data will be overwritten.
-

6

Collect the work from the front area

- Turn the vacuum off and collect the work.
-

7

Set up a new work in the front area, then turn the vacuum on.

- After drawing in the rear area is finished, start drawing in the front area.
-

8

After drawing in the rear area is finished, collect the work.

- Set up a new work, then turn the vacuum on.
 - After drawing in the front area is finished, start drawing in the rear area.
-

9

From this point, keep collecting finished works and setting up new ones.

10

When drawing in only one area

- Drawing priority is given to the area where the work is ready. For this reason, if a new work is not set up after drawing in the rear area is finished, for example, the machine does not switch to the rear area after drawing in the front area is finished.

In this state, after the work in the front area is collected, a new work is set up, the vacuum is turned on, and drawing will be performed in the front area.

11

Pause operation as needed.

- Press the [LOCAL] key while drawing is in progress.

Important!

- The active area does not change during drawing, including when paused.
-

12

To exit toggle mode, clear the data either after drawing is finished in either area or when drawing is paused.

- Clearing the data discards both front and rear drawing data.
-

13

Use new data for drawing, as needed.

- To prepare new drawing data, clear the data and start over from the beginning.
-

Restrictions in Continuous and Toggle Modes

- (1) Cutting area settings have no effect in toggle mode. The maximum drawing area corresponds to the cutting area.
- (2) In toggle mode, the axis correction setting has no effect.
- (3) In toggle mode, these kinds of drawing are only possible in the front area: “Sample Cutting” (☞ P.8-15), “Test Cutting (☞ P.3-38),” and “Adjusting Tools (☞ P.3-22).”
- (4) If an internal pattern is drawn in continuous mode, the data received will be discarded.
- (5) If new data is received between drawings when [Cut data] is set to [Copy], the original data is discarded and the new data is used.
- (6) New data cannot be received while drawing is in progress or paused (in toggle mode, rear area drawing data cannot be sent while the front area is being used for drawing).
- (7) The [Vacuum Auto-On] setting has no effect. Vacuum operation is not interlocked with switching between [Remote] and [Local].
- (8) These modes cannot be used at the same time as single mode for continuous register mark cutting. (Can be used in multi mode)
- (9) These modes cannot be used at the same time as the edge detection function.
- (10) These modes cannot be used at the same time as the backside cutting function.
- (11) In continue mode and toggle mode, data cannot be cut if it exceeds the cutting buffer size (normally 22 MB, and 16 MB when sorting is enabled).
- (12) In continuous mode/toggle mode uses the vacuum switch as start-up and switching operation, so vacuum switching by command is disabled.

Settings Initialized by Enabling/Disabling Continue Mode

Changing continuous mode from [Enable] to [Disable] or vice versa initializes or disables the following.

- (1) Received data is discarded (data is cleared).
 - This also disables copying of received data.
- (2) Cutting area settings are canceled (initialized).
- (3) The axis correction setting is canceled (initialized).
- (4) Work thickness is considered not set.
- (5) When the setting is changed from [Enable] to [Disable], the drawing origin is set to the lower right of the screen (the origin at startup).

About the flat follow-up function

Flat follow-up function

The flat follow-up function is a function that corrects the height of various points during cutting based on measurements of the felt surface height made beforehand using flatness measurement.

If there are locations that are not fully cut through when cutting shapes, the flat follow-up function can be enabled to ensure that those areas are fully cut through.

Adjust the [Zorg Offset] value to ensure full cutting through via test cuts near the origin point at the lower right, which forms the datum point for flatness measurement.

Tools for which flat follow-up can be used:

1. Flat blade tool (FBT)
2. Creasing roller (C16/C26/C60/C6A)
3. Reciprocating cutter (E12/E35/E60)
4. V-cut tool (V45/VAS)
5. End mill (R10)



- The creasing roller can be used when the pressure level setting is disabled (position control).



- The flat follow-up function cannot be used with the following operations, even when it is enabled:
 - Test Cut
 - Sample Cutting
 - Tool Adjust
 - Manual Cut
- The flat follow-up function cannot cope with excessive unevenness, such as debris on the felt surface during measurement.
- Enabling the flat follow-up function may reduce the speed.
The flat follow-up function increases tracking accuracy by performing multiple corrections according to the height of the felt mat surface. Therefore, long cutting movements are divided into sections, and the height is corrected at the division points. This division may reduce the movement speed.
The flat follow-up function should be disabled if speed is a priority.
- When the flat follow-up function is enabled, operation may not stop immediately when a remote key is pressed to pause operation. This is due to the line divisions described above.

Setting the flat follow-up function

1 On the local mode screen, press [MENU].

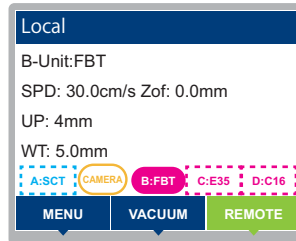

2 Press ▲ ▼ to select [Setup] > [Draw] > [Flat Follow-Up], then press the [ENTER] key.

3 Press ▲ ▼ to select the tool to be set, then press the [ENTER] key.

Available tool groups

- FBT
- C16/C26/C60/C6A
- E12/E35/E60
- V45/VAS
- R10

Important!

- C16/C26/C60/C6A, E12/E35/E60, or V45/VAS cannot be set individually.
- If the same tool is mounted on more than one unit (for example, if FBTs are mounted on the B and C units), they cannot be set individually for each unit.

4 Press ▲ ▼ to select the setting.

- Setting values: ON (flat follow-up enabled), OFF (flat follow-up disabled)
- Default: OFF

5 Press the [ENTER] key

- The value entered is saved.
- To exit without saving, press the [END/POWER] key.

6 To exit, press the [END/POWER] key several times to return to the local mode screen.

Setting the felt mat flatness

Important!

- The felt mat is measured over the entire drawing area. The measurement area cannot be specified.
- Do not place work or other objects on top of the felt mat when measuring.
- Remove any debris on top of the felt mat.
- The flatness of the felt mat must be measured in order to use the flat follow-up function. If the state of the felt mat has changed with use, measure the flatness using this menu.

1

On the local mode screen, press [MENU].

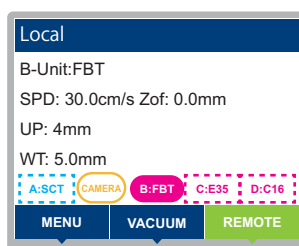

2

Press ▲▼ to select [Machine Setup], then press the [ENTER] key.

3

Press ▲▼ to select [Flatness], then press the [ENTER] key.

4

Press the [ENTER] key to start measurement.

- Progress is indicated as a percentage while measurement is in progress.

5

When measurement is complete, this is displayed on the screen. Press the [ENTER] key to exit this menu.



A warning is displayed if there is a problem with the measurement results.

Check the following:

- Check for any debris on the felt mat
- Check for any deep depressions or cuts on the felt mat

Setting Felt Mat Thickness

Changes in the thickness of the felt mat due to factors such as wear will affect the work thickness measurement results.

The felt mat thickness can be set using either of the following methods.

- Update the felt mat thickness using the flatness measurement value (☞“Set by measuring flatness”P.4-31)
- Enter the felt mat thickness manually (☞“Entering values manually”P.4-33)



- When setting the felt mat thickness automatically, flatness measurement must also be performed. If you wish to set only the felt mat thickness, it must be entered manually.
- Changing the felt mat thickness clears the previously measured work thickness. The work thickness should be set again.



- The felt mat can be used with either side of facing up. However, compared to using the side that was facing up during shipping (the rough side), using the side that was facing down during shipping (the smooth side) as the top surface will cause damage from processing to progress more easily.
- When using the mat with the reverse side facing up, please switch sides only after the top surface has been sufficiently used.
- After switching the surface and back sides of the mat, always perform a flatness measurement again.
- The felt mat and double-sided tape are easily peeled off immediately after attachment but adhere more strongly after a period of time.

Set by measuring flatness

1

On the local mode screen, press [MENU].

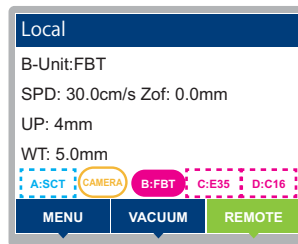

2

Press ▲ ▼ to select [Machine Setup], then press the [ENTER] key.

3

Press ▲ ▼ to select [Flatness], then press the [ENTER] key.

4

Press the [ENTER] key to start measurement.

- Progress is indicated as a percentage while measurement is in progress.

5

When measurement is complete, this is displayed on the screen. Press the [ENTER] key to exit this menu.



A warning is displayed if there is a problem with the measurement results.

Check the following:

- Check for any debris on the felt mat
- Check for any deep depressions or cuts on the felt mat

6

If measurement was successful, pressing the [ENTER] key in Step 5 displays the felt mat thickness update screen.



The felt mat thickness calculated from the flatness measurement is displayed.

Check the measurement results, and to update the felt mat thickness, press the [ENTER] key.

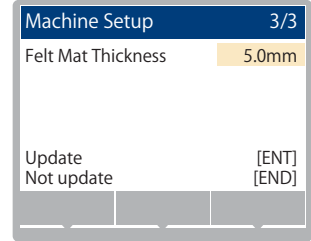
To exit without updating, press the [END] key.



Hint!

- The settings can be altered using the   keys before pressing the [ENTER] or [END] key for the measurement results.



- Upper and lower limits apply to the felt mat thickness. If the measurement results are outside the upper or lower limits, a warning is displayed, and the corresponding upper or lower limit is displayed.

Entering values manually

1 On the local mode screen, press [MENU].

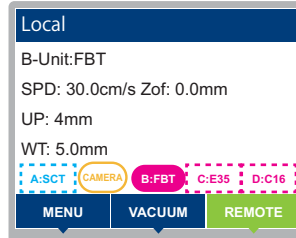

2 Press ▲ ▼ to select [Machine Setup], then press the [ENTER] key.

3 Press ▲ ▼ to select [Felt Mat Thickness], then press the [ENTER] key.

4 Press ▲ ▼ to enter the felt mat thickness.

- Setting values: 2.0 to 6.0 millimeters
- Default: 4.2 mm

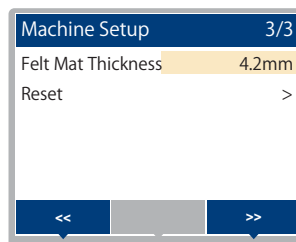

5 Press the [ENTER] key.

- The value entered is saved.
- To exit without saving, press the [END/POWER] key.

Important!

- Do not place the work raised more than 6 mm from the cutting panel surface (6 mm is the maximum thickness of the felt mat). There is a risk of insufficient raising height, particularly when using the creasing roller.

Setting Cutting Quality

Set the cutting quality.

1 On the local mode screen, press [MENU].

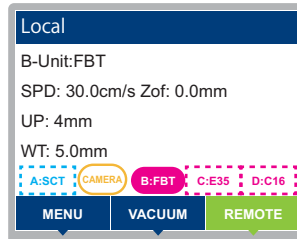

2 Press \triangle ∇ to select [Setting] > [Draw] > [Cut Mode], then press the [ENTER] key.

3 Press \triangle ∇ to select the setting.

- Normal: Regular cutting mode.
- Quality: Mode that prioritizes cutting quality.
- Fast: Mode that prioritizes cutting time.
- Draft: It takes the shortest amount of time to cut. This reduces the cut quality. (Drafts are supported from firmware version 1.8.0).

4 Press the [ENTER] key.

- To exit without saving, press the [END/POWER] key.

5 To exit, press the [END/POWER] key several times to return to the local mode screen.

- Hint!**
- Set to [Sharp] when cutting the following kinds of data.
 - a Text that is 10 mm or smaller
 - b Patterns or text with many sharp edges
 - c Fine cuttingNote that the finish may be rough if the data sent from the computer is too intricate. In this case, select [Fast] for a smoother finish.

Setting the Speed of Head Movement

Set the speed of head movement when tools are up.

With [Auto] selected, the cutting speed setting value in cutting conditions corresponds to the speed when up.

1 On the local mode screen, press [MENU].

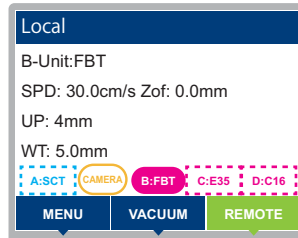

2 Press \uparrow \downarrow to select [Tool] > [Tool Setting], then press the [ENTER] key.

3 Press \uparrow \downarrow to select the tool.

- For units with many available tools, use \ll \gg to switch screens.
- Configurable tools vary by unit. (☞ Unit and Tool Combinations)

Important!

- Regardless of the tools actually mounted, tool settings for each unit can be configured.
- Tool settings are saved on a per-unit basis. They are not applied to other units.

4 Press the [ENTER] key.

- The settings are saved.
- To exit without saving, press the [END/POWER] key.

5 Press \uparrow \downarrow to select [Up speed], then press the [ENTER] key.

- Items displayed vary by tool. (☞ Setting items)

6 Press \uparrow \downarrow to select the setting.

- Setting values: Auto, 5, 10 to 100 cm/s (in 10 cm/s increments)

7 Press the [ENTER] key.

- The settings are saved.
- To exit without saving, press the [END/POWER] key.

8 To exit, press the [END/POWER] key several times to return to the local mode screen.

Setting an Offset for Adjusted Blade Pressure (Standard Unit)

Set when there are uncut portions at the beginning and end of cuts, and in other situations.

1 On the local mode screen, press [MENU].

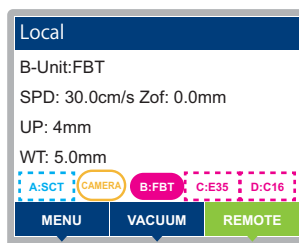

2 Press ▲ ▼ to select [Tool] > [Tool Setting], then press the [ENTER] key.

3 Press ▲ ▼ to select [A-Unit] > [A-Unit: SCT], then press the [ENTER] key.

- For units with many available tools, use << >> to switch screens.
- Configurable tools vary by unit. (☞ Unit and Tool Combinations)

Important!

- Regardless of the tools actually mounted, tool settings for each unit can be configured.
- Tool settings are saved on a per-unit basis. They are not applied to other units.

4 Press the [ENTER] key.

- The settings are saved.
- To exit without saving, press the [END/POWER] key.

5 Press ▲ ▼ to select [Adj-prs Offset], then press the [ENTER] key.

- Items displayed vary by tool. (☞ Setting items)

6 Press ▲ ▼ to select the setting.

- Setting values: -9 to 9 (approx. -30 g to 30 g)

7 Press the [ENTER] key.

- The settings are saved.
- To exit without saving, press the [END/POWER] key.

8 To exit, press the [END/POWER] key several times to return to the local mode screen.

Eliminating Pieces Left Uncut in Works (Standard Unit)

Intentionally overlapping the start and end points prevents the work from being left uncut.

Specify whether overcutting is enabled or disabled, and set the length. When an overcutting length is set, a cut of the specified length is made back from the starting point, and the tool is raised after intentional overcutting at the end.

Overcutting is also performed at corners other than start and end points.

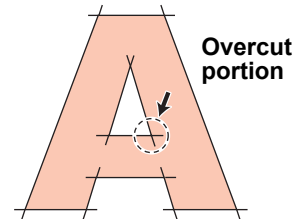

Important!

- Setting up suitable overcutting can reduce pieces left uncut at the beginning and end of cuts on works that are easily bent. Avoid setting the value too high, which may leave scratches on the finished piece.
- Overcutting only applies to drawing with a swivel cutter.

1

On the local mode screen, press [MENU].

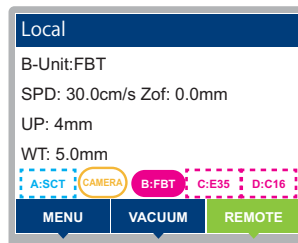

2

Press \uparrow \downarrow to select [Tool] > [Tool Setting], then press the [ENTER] key.

3

Press \uparrow \downarrow to select the tool.

- For units with many available tools, use \ll \gg to switch screens.
- Configurable tools vary by unit. (☞ Unit and Tool Combinations)

Important!

- Regardless of the tools actually mounted, tool settings for each unit can be configured.
- Tool settings are saved on a per-unit basis. They are not applied to other units.

4

Press the [ENTER] key.

- The settings are saved.
- To exit without saving, press the [END/POWER] key.

5

Press \uparrow \downarrow to select [Over Cut], then press the [ENTER] key.

- Items displayed vary by tool. (☞ Setting items)

4

6

Press ▲▼ to select the overcut setting.

- Setting values: Off or 0.1 to 1.0 mm (in 0.1 mm increments)

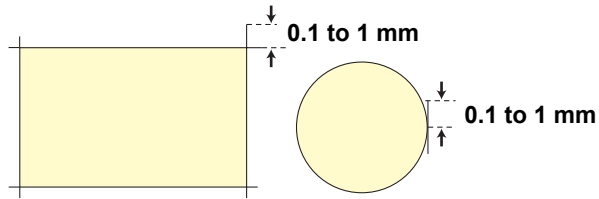

7

Press the [ENTER] key.

- The settings are saved.
 - To exit without saving, press the [END/POWER] key.
-

Setting Up a Double Roller Effect

Two crease lines can be drawn, centered on and offset from the position of a normal crease line.

Important!

- The normal crease line is not drawn.

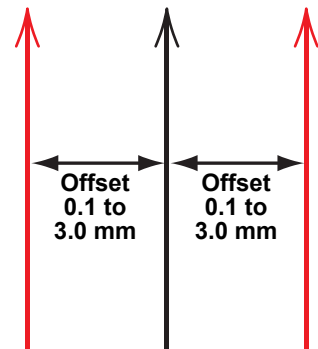

— : Normal crease line

— : With the double roller effect enabled, these crease lines are actually drawn

1 On the local mode screen, press [MENU].

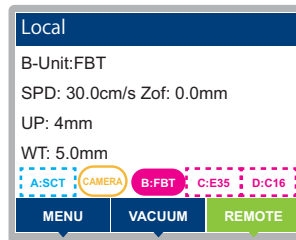

2 Press ▲ ▼ to select [Tool] > [Tool Setting], then press the [ENTER] key.

3 Press ▲ ▼ to select the unit to which the crease tool (C16, C26, C60, C6A) is mounted, then press the [ENTER] key.

- The crease roller can be mounted on B, C, or D.
- Setting values: A, B, C, D

4 Press ▲ ▼ to select the crease tool (C16, C26, C60, C6A), then press the [ENTER] key.

5 Press ▲ ▼ to display [Double Roller], then press the [ENTER] key.

6 Press ▲ ▼ to set a setting value, then press the [ENTER] key.

- The double roller function is not used when [OFF] is selected for the setting value.
- Setting values: OFF, 0.1 to 3.0 mm

Hint!

- A (w) is displayed after the tool name when the double roller is set to an option other than off.

7 To exit, press the [END/POWER] key.

Setting the Display Language

Select English or Japanese as the display language.

1 On the local mode screen, press [MENU].

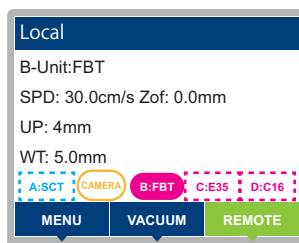

2 Press \triangle ∇ to select [Machine Setup] > [Language], then press the [ENTER] key.

3 Press \triangle ∇ to select the language.

- Setting values: English, Japanese

4 Press the [ENTER] key.

- The settings are saved.
- To exit without saving, press the [END/POWER] key.

5 To exit, press the [END/POWER] key several times to return to the local mode screen.

Setting the Display Unit

Select the length unit displayed for jog functions.

Setting value	Overview
mm	Displays values in millimeters
inch	Displays values in inches

1 On the local mode screen, press [MENU].

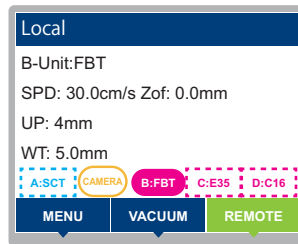

2 Press ▲ ▼ to select [Machine Setup] > [Unit: Length], then press the [ENTER] key.

3 Press ▲ ▼ to select the setting.

- Setting values: mm, inch

4 Press the [ENTER] key.

- The settings are saved.
- To exit without saving, press the [END/POWER] key.

5 To exit, press the [END/POWER] key several times to return to the local mode screen.

Setting the Key Buzzer

You can turn off the buzzer sound that is played when keys are pressed.

1 On the local mode screen, press [MENU].

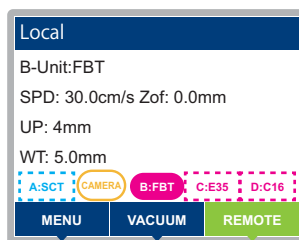

2 Press ▲ ▼ to select [Machine Setup] > [Key Buzzer], then press the [ENTER] key.

3 Press ▲ ▼ to select the On / Off.

- Setting values: On, Off

4 Press the [ENTER] key.

- The settings are saved.
- To exit without saving, press the [END/POWER] key.

5 To exit, press the [END/POWER] key several times to return to the local mode screen.

Hint! • Setting the buzzer to OFF does not disable sounds for errors, warnings, or completion of operation.

Setting Startup Mode

Set the mode that is active after the machine is turned on.

1 On the local mode screen, press [MENU].

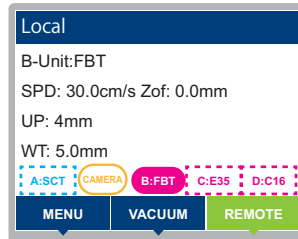

2 Press ▲ ▼ to select [Machine Setup] > [Startup Mode], then press the [ENTER] key.

3 Press ▲ ▼ to select Local or Remote mode.

- Setting values: Local, Remote

4 Press the [ENTER] key.

- The settings are saved.
- To exit without saving, press the [END/POWER] key.

5 To exit, press the [END/POWER] key several times to return to the local mode screen.

- Hint!**
- When [Startup Mode] is set to remote, cutting edge detection is automatically performed immediately after startup.

Setting Commands

Setting Priority

Set which settings take priority if a setting item has been set differently on the machine and host computer.

1 On the local mode screen, press [MENU].

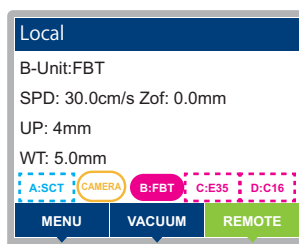

2 Press ▲▼ to select [Setting] > [Command] > [Priority], then press the [ENTER] key.

3 Press ▲▼ to select the setting.

SP	Selecting tools
VS	Setting movement speed
AS	Setting acceleration
FS	Setting tool pressure
ZF	Setting cutting pressure
ZA	Setting movement speed with tools up
ZO	Setting the amount of blade correction

4 Press the [ENTER] key.

- To exit without saving, press the [END/POWER] key.

5 Press ▲▼ to select the setting.

- Setting values: Host, Panel
 - Host:Host computer setting values take precedence.
 - Panel:Machine setting values take precedence.
- To set other items, repeat steps 4 to 7.

6 Press the [ENTER] key.

- To exit without saving, press the [END/POWER] key.

7 To exit, press the [END/POWER] key several times to return to the local mode screen.

Setting Effective Area Return Values (OH:Response Value)

Set which value to return to the software after the machine receives a command to return effective area coordinates to the software.

Default: Returns the machine's maximum effective cut area value.

Setting values: Returns the value set in the [Cut Area] setting.

1 On the local mode screen, press [MENU].

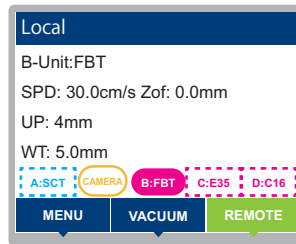

2 Press ▲ ▼ to select [Setup] > [Command] > [OH: Response Value], then press the [ENTER] key.

3 Press ▲ ▼ to select the setting.

- Setting values: Initial value, Setting value

4 Press the [ENTER] key.

- To exit without saving, press the [END/POWER] key.

5 To exit, press the [END/POWER] key several times to return to the local mode screen.

Setting Computer Connection Conditions

The communication conditions must be set to suit the interface used.



- Connect and disconnect the cables carefully. Applying excessive force to the cables may damage them.

Using a LAN Cable

Connect a host PC to the machine using a LAN cable. Insert a LAN cable until it engages with a click.



- Do not unplug the cable while data is being transferred.

● Network Connection Precautions

Make sure the network is set up as follows: Cutting will not be possible if the network is not set up correctly.

- Use a Category 6 or Category 6A LAN cable.
- The machine and host PC must be set for the same local network. This product cannot be connected via a router.
- Use a 1000BASE-TX compatible computer or switching hub. Cutting requires 1000BASE-TX support.

Using an RS-232C Cable

Connect a host PC to the machine using an RS-232C cable.



- Turn off the power to the machine and host PC before connecting the cable.



- Do not unplug the cable while data is being transferred.

1

On the local mode screen, press [MENU].

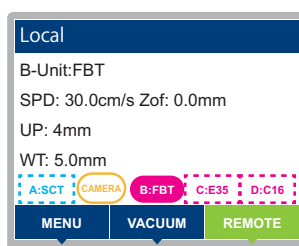

2

Press \uparrow \downarrow to select [Communication Set] > [RS-232C] > [Baud Rate], then press the [ENTER] key.

3

Press \uparrow \downarrow to select the setting.

- Setting values: 1200, 2400, 4800, 9600, 19200, 38400 (bps)



- The recommended setting is 38400 (bps).
- Set the host computer transfer speed to match the machine.

4**Press the [ENTER] key.**

- To exit without saving, press the [END/POWER] key.

5**Press ▲ ▼ to select each of the following settings, then press the [ENTER] key.**

- RS-232C settings include the following items.
Data Len, Parity Bit, Stop bit, Handshake
- For details on each setting item, see P.4-47.

6**Press ▲ ▼ to select the setting value.**

- For details on each setting item, see P.4-47.

7**Press the [ENTER] key to confirm the setting values.**

- To exit without saving, press the [END/POWER] key.

8**To exit, press the [END/POWER] key several times to return to the local mode screen.**

Setting items

Baud Rate	1200, 2400, 4800, 9600, 19200, 38400 (bps)
Data Len	7, 8 (bit)
Parity	None, Odd, Even
Stop Bits	1, 2 (bit)
Handshake	X-PRM, None

Setting the Network

Important!

- Network settings are not user-specific settings. For example, settings made for user 1 also apply to users 2 to 4.

1 On the local mode screen, press [MENU].

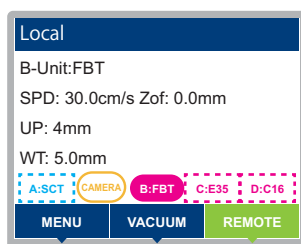

2 Press \triangle ∇ to select [Communication Set] > [Network], then press the [ENTER] key.

3 Press \triangle ∇ to select [Check IP Address], then press the [ENTER] key.

- Shows the current IP address of the machine.

Hint!

- It takes some time after a network connection is established until the IP address is determined. "0.0.0.0" is displayed when the IP address has not been determined yet.

4 Press the [ENTER] key.

5 Press \triangle ∇ to select [Check MAC Address], then press the [ENTER] key.

- Shows the current IP address of the machine.
- Press \blacktriangleright to display the next address.

6 Press the [ENTER] key.

7 Press \triangle ∇ to select [DHCP], then press the [ENTER] key.

- Press \triangle ∇ to select On / Off.
- Set to ON to use an IP address set by the DHCP server.

8 Press the [ENTER] key.

9 Press \triangle ∇ to select [Auto IP], then press the [ENTER] key.

- Press \triangle ∇ to select On / Off.
- Set to ON to use an IP address set via the AutoIP protocol. Note that DHCP is given priority when DHCP is set to ON.

10 Press the [ENTER] key.

- If either DHCP or AutoIP is set to [ON], go to step 15.
- If both DHCP and AutoIP are set to [OFF], go to step 11.

11 Press ▲▼ to select the next setting item.

- When both DHCP and AutoIP are set to [OFF], set the IP address, default gateway, DNS address, and subnet mask.

Hint!

- IP Address: Sets the IP address used by the machine.
- Default Gateway: Sets the default gateway used by the machine.
- DNS Address: Sets the DNS server address used by the machine.
- Sub Net Mask: Sets the subnet mask used by the machine based on the number of digits from the highest position when represented in binary format.

12 Press the [ENTER] key.

13 Press ▲▼◀▶ to set.

14 Press the [ENTER] key to confirm the setting values.

- To exit without saving, press the [END/POWER] key.

15 To exit, press the [END/POWER] key several times to return to the local mode screen.**Hint!**

- Restart the machine to apply network settings.

Copying Setting Values from Another User's Settings

1 On the local mode screen, press [MENU].

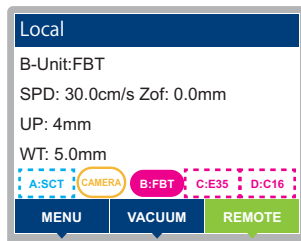

2 Press \triangle ∇ to select [Setup] > [Setup Copy], then press the [ENTER] key.

3 Press \triangle ∇ to select [Target], then press the [ENTER] key.

4 Press \triangle ∇ to select a setting option, then press the [ENTER] key.

- Setting values: Draw, Command, Tool, All

5 Press \triangle ∇ to select [Copy From], then press the [ENTER] key.

6 Press \triangle ∇ to select a setting option, then press the [ENTER] key.

- Setting values: Setting 1 to 4 (other than the current setting number)

Hint! • The current setting number is indicated in [Copy To]. (This number cannot be changed.)

7 Press \triangle ∇ to select [Execute], then press the [ENTER] key.

- Setting values: 1 to 4 (other than the current setting number)

8 Check the setting details and press [COPY].

- The setting values are copied.
- To exit without changing the settings, press the [END/POWER] key.

9 To exit, press the [END/POWER] key several times to return to the local mode screen.

Restoring Default Settings

1 On the local mode screen, press [MENU].

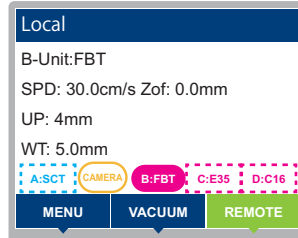

2 Press ▲ ▼ to select [Setup] > [Setup Reset], then press the [ENTER] key.

3 Press [RESET].

- Settings will be reset.
- To exit without changing the settings, press the [END/POWER] key.

4 To exit, press the [END/POWER] key several times to return to the local mode screen.

Setting the Reciprocating Cutter Blade Position

The reciprocating cutter cuts by vibrating the tool up and down, but the lowest point of the blade reciprocating movement can be set.

In mat: Positions the blade inside the mat at its lowest reciprocating point. Cuts with the blade penetrating the mat, but cuts without leaving dotted lines.

On mat: Positions the blade on the mat surface at its lowest reciprocating point. Cuts without the blade penetrating the mat, so minimizes damage to the mat. However, dotted line cutting may result, preventing cutting unless the cutting speed is reduced.



- Be sure to readjust the reciprocating cutter tool if this setting has been altered. Readjustment is required particularly for CENTER A.

1

On the local mode screen, press [MENU].

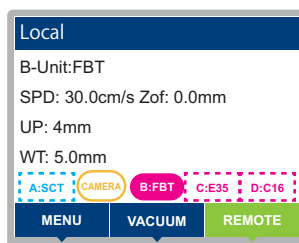

2

Press \blacktriangle \blacktriangledown to select [Machine Setup], then press the [ENTER] key.

3

Press \blacktriangle \blacktriangledown to select [Reciprocating Setup], then press the [ENTER] key.

4

Press \blacktriangle \blacktriangledown to select the [Blade lowest pos.] setting.

- Setting values: In mat, On mat
- Default: In mat

5

Press the [ENTER] key.

- The value entered is saved.
- To exit without saving, press [END/POWER].

6

To exit, press the [END/POWER] key several times to return to the local mode screen.

Checking the Cutting Area in Advance

Check to confirm that the cut data will fit within the work mounted on the machine.
This requires an application that supports this function. (E.g., Mimaki FineCut9)

The work thickness is measured at multiple points to determine whether a work is present from the height differences.

The following precautions must be noted to ensure that this function is used correctly:



- (1) Work thickness detection is used, so the pen cap holder should be mounted in the A-Unit tool.
- (2) Make sure that the work is always present at the drawing origin (lower right position) for the cutting range.
- (3) If the unevenness of the work surface is 1 mm or more, the work will not be detected. Do not use this function.
- (4) If the work is less than 1 mm thick, it cannot be detected. This is outside the detection range, and the work is always determined to be present.
- (5) The work cannot be detected correctly unless the margins are 13 mm or more for the actual cutting range.
 - Do not use this function when drawing in full size or offscale. As margins are required, as described above, using this function to check the cutting range will result in the work not being detected.
- (6) If axis correction (2-point axis correction) is enabled on the machine, select 4-point detection. As the axis is tilted, correct detection may not be possible using 2-point detection.
- (7) If the work is present after checking, cutting starts.
- (8) If the work is not present after checking, cutting does not start, and a warning is displayed before the machine returns to local mode.
 - Either replace the work, reposition it, or change the drawing origin to allow cutting to start. Once the issue has been resolved, either resend the data or copy it.
- (9) Using this function does not update the previously set work thickness.
For details on work thickness detection, see P.3-9「Securing Works」 and P.4-3「Thickness Detect」.

Switching Users

Setting values for cutting conditions and main unit settings can be saved separately for up to four users (users 1 to 4).

Selecting a user number corresponding to the user allows the configuration to be changed without the need to reset parameters.

Important!

- The user cannot be changed while cutting is suspended. Clear the data before changing the user.
- To copy another user's setting values, use "Setup Copy (☞ P.4-50)."

1

On the local mode screen, press [MENU].

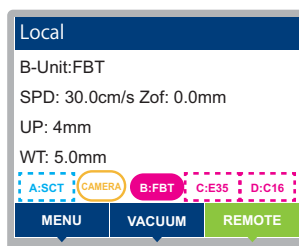

2

Press ▲▼ to select [Setting] > [Change User], then press the [ENTER] key.

3

Press ▲▼ to select the setting.

- Setting values: 1 to 4

4

Press the [ENTER] key.

- To exit without changes, press the [END/POWER] key.

5

To exit, press the [END/POWER] key several times to return to the local mode screen.

Checking Machine Information

Enables you to check information about the machine.
You can check the following items of machine information.

Item		Explanation
Power ON Time		Indicates cumulative hours of use.
Version	Model	Identifies the model.
	Serial No.	Indicates the serial number of the machine.
	Firmware	Indicates the machine firmware version.
	Command	Indicates the name and version of commands supported by the machine.
Error History		Shows a record of past errors.
Unit & Tool		Indicates the units mounted in stations A to D, and the tools.
Usage		Indicates the usage time for the drive system parts. Indicates if the recommended replacement intervals are close or exceeded.

1 On the local mode screen, press [MENU].

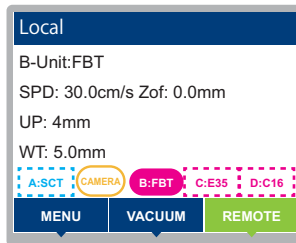

2 Press ▲ ▼ to select [Information], then press the [ENTER] key.

3 Press ▲ ▼ to select the machine information to display.

- There is no need to select [Power ON Time].

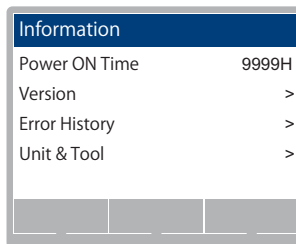

4 Press the [ENTER] key.

- A screen is displayed with information to review.
- The following information is displayed when you select [Error History].
- Press ▲ ▼ to display the next screen of the error history.

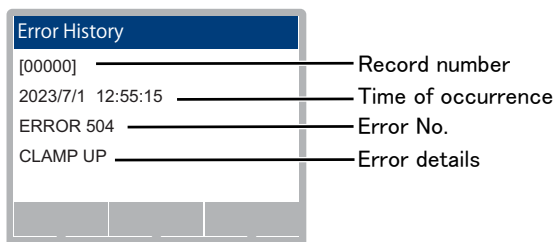

Updating the Machine Firmware

The Mimaki Firmware Updater can be used to update the machine firmware.
The Mimaki Firmware Updater can be downloaded from our website.

1 Connect the machine to the host PC using a LAN cable.

2 On the local mode screen, press [MENU].

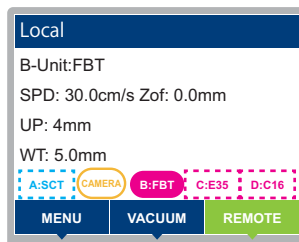

3 Press ▲▼ to select [Firmware Update].

- Pressing the [END] key exits firmware updating.

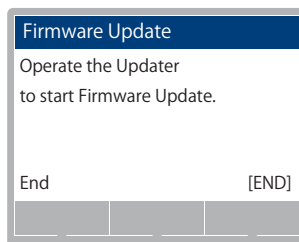

4 Use the Mimaki Firmware Updater to start updating the machine firmware.

- The machine automatically restarts while updating is in progress.

Important!

- Do not turn off the power or operate the machine while updating is in progress.
Failure to operate in accordance with the instructions provided by the updater may result in serious malfunctioning of the product.
-

Chapter 5

Register Mark Reading Functions



About this chapter

This chapter describes how to create register mark data and the register mark scanning functions.

Precautions When Preparing Data with Register Marks	5-2	Detecting the Mark Origin	5-15
Register Mark Size	5-2	Setting Mark Origin in Teaching Mode	5-16
Supported Arrangements of Register Marks and Patterns	5-4	Aligning the Register Mark Detection Position	5-17
No-Drawing Areas Around Register Marks ..	5-6	Continuous Cutting with Register Marks	5-19
Register Mark Color	5-9	Linking Cutting and Printing (ID Cut).....	5-20
Blurry or Smudged Register Marks	5-9	Setting Up ID Cut	5-20
Setting Mark Detection Operation.....	5-10	Backside Cutting Using Mark Chips.....	5-21
Precautions on Mark Detection	5-10	Surface Cutting Using Edge Detection.....	5-23
Setting Mark Detection Operation	5-11	Backside Cutting Using Edge Detection	5-24
Mark Detection Camera Adjustment	5-13		
Mark Detection Mode	5-14		

Precautions When Preparing Data with Register Marks

Several restrictions apply when preparing data with register marks.

To take full advantage of register mark functions, read the following precautions carefully and prepare register marks correctly.

Hint!

- The register marks described here are used to detect work skewing and X and Y axis lengths, which distinguishes these marks from trimming register marks.

Register Mark Size

● Mark Form: Type.1, Type.2

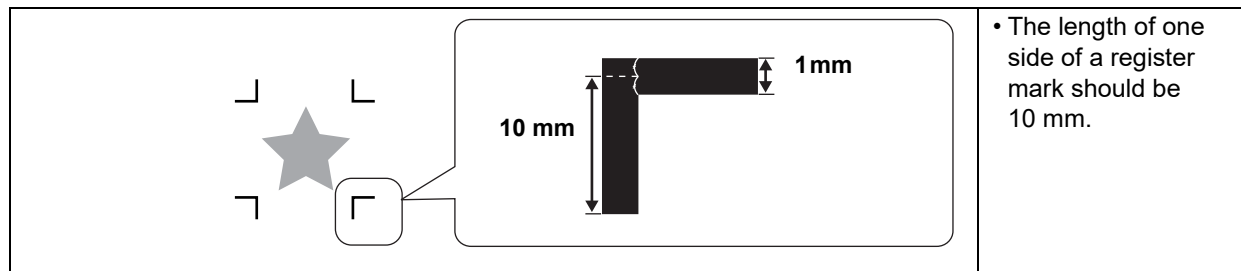

● Mark Form: Type.3, Type.4

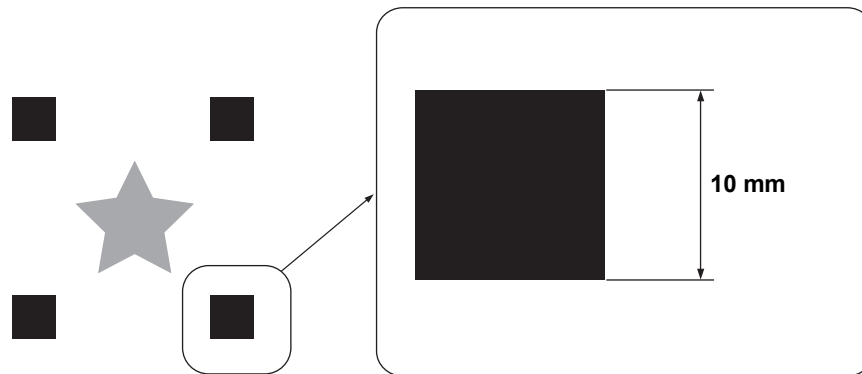

Hint!

- The Type.3 and Type.4 marks are identical, but Type 4 can be printed without margins for multiple originals arranged together in multi-mode copying.

● Mark Form: Type.5

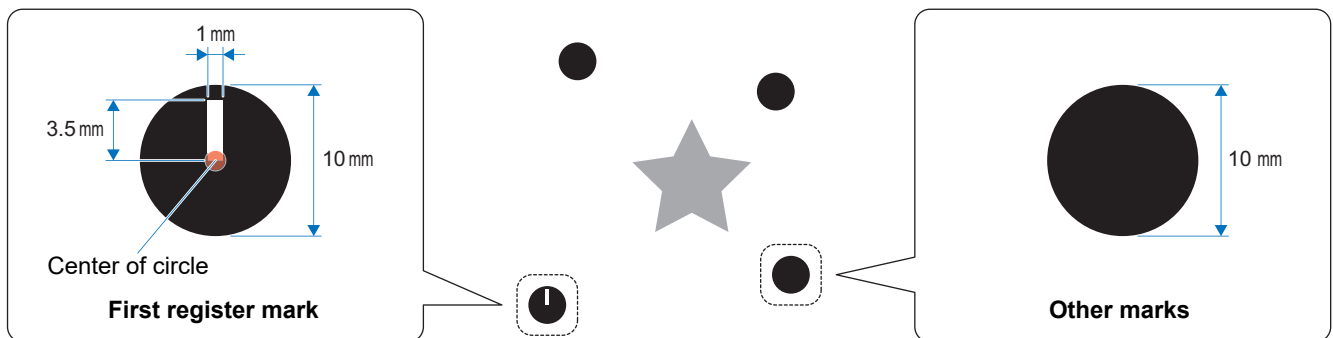

Important!

- In free arrangement mode, prepare marks with a diameter of 10 mm.
- Free arrangement mode requires an optional camera.
- The first 1 mm wide slit in free arrangement mode indicates the axis direction of the coordinate system. The direction in which the slit extends from the center of the circle is the positive X axis (0 degree direction).
- To determine the position of the second and subsequent register mark detection positions, the axis direction must be read, and the orientation of the work must be determined. Therefore, mark origin detection must always be performed when using Type.5 marks. (☞ P.5-15 "Detecting the Mark Origin") If a Type.5 mark is detected without first performing mark origin detection with a command, a "Mark origin not detected" warning will appear, and the unit will switch to LOCAL mode. If the work has not been rotated, switching back to REMOTE mode will resume normal operation. However, if the work has been rotated, clear the data and perform mark origin detection. Additionally, perform mark origin detection each time the work is rotated (0°, 90°, 180°, or 270°) or the position of the work is changed.

● Mark Form:Type.6

The register mark can be any shape. Specify any four points using a camera for correction.

● Mark Form:Type.7

Like Type5, it is a free mode. Differences include.

- The register mark size is variable from 3 mm ~ 12 mm and is specified by command.
- The dragonfly at the first register mark and other register mark have the same shape.
- They can only be detected by command (the mark origin cannot be set).
- Before receiving command data, the drawing origin must be aligned with the first point's dragonfly position. (☞ P.3-45 "Setting the Drawing Origin")

Supported Arrangements of Register Marks and Patterns

Leave a margin of at least 10 mm between register marks and the edge of the work.

Hint!

- Sensors must be positioned over the marks to read them. For this reason, square marks are recommended.

Important!

- Leave a margin of at least 30 mm from the edge of the work for edge detection. Otherwise the register mark may cause incorrect edge detection.

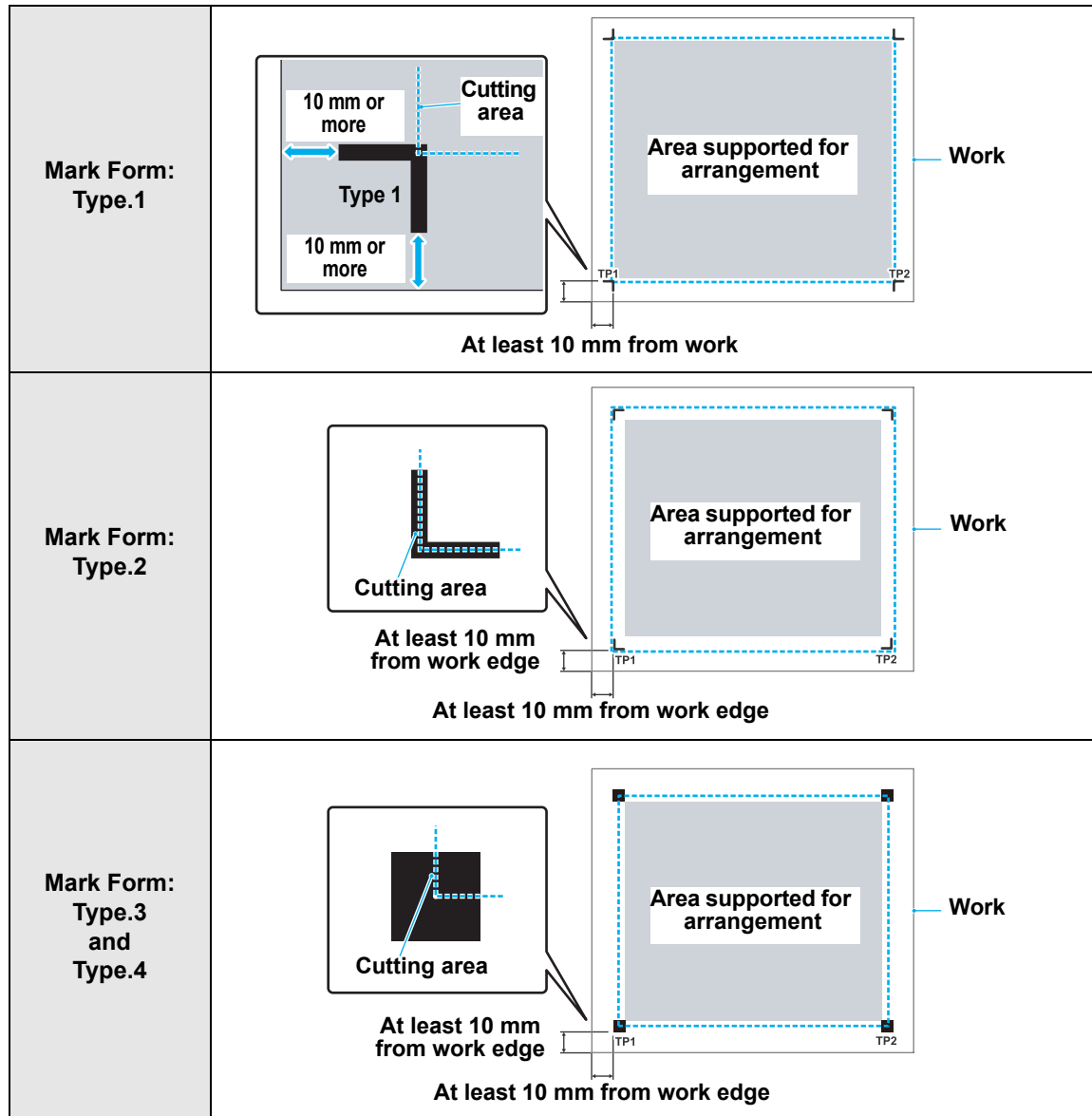

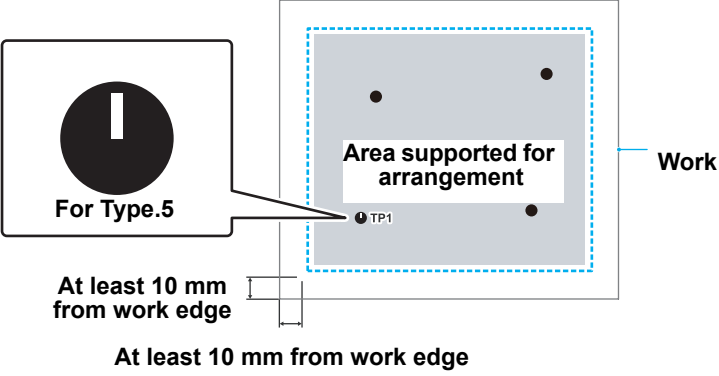
<p>Mark Form: Type.5 and Type.7 in free arrangement mode (requires an optional camera)</p>	 <p>For Type.5</p> <p>Area supported for arrangement</p> <p>Work</p> <p>TP1</p> <p>At least 10 mm from work edge</p> <p>At least 10 mm from work edge</p>
<p>Mark Form: Type.6 (requires an optional camera)</p>	<p>This can be any shape. Specify the position using the camera. There are no particular restrictions relating to positioning area.</p>

No-Drawing Areas Around Register Marks

Keep the area around register marks (from the mark origin and including the mark itself) free of both data and debris. If not, misdetection or scanning errors may occur.

Hint!

- Misdetection of the mark origin will cause the cutting position to be shifted.
- The LED pointer position for mark detection is the same whether a camera is used or not.
- With camera detection, the requirement to keep the area around the mark (30 mm × 40 mm) free of data applies to Type.1 to Type.4 as well as Type.5 and Type.7.
- No particular restrictions apply to Type.6.

Mark Form:Type.1 (outer)

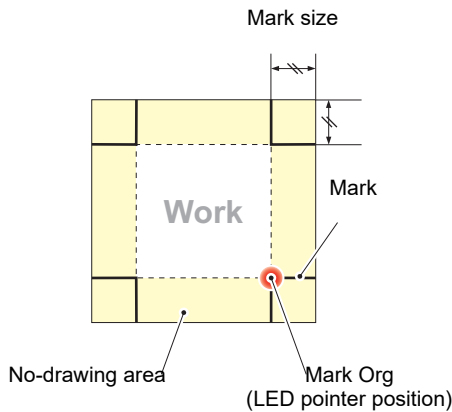

Mark Form:Type.2 (inner)

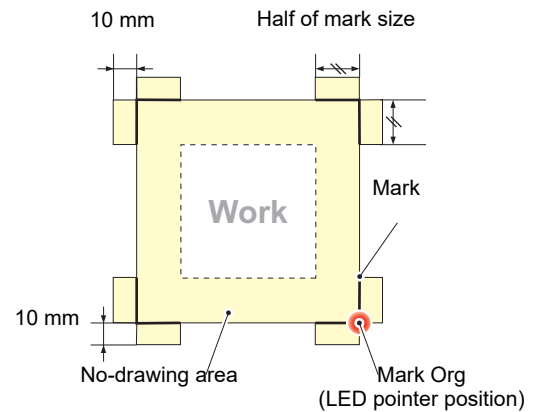

Mark Form:Type.3, Type.4 (square)

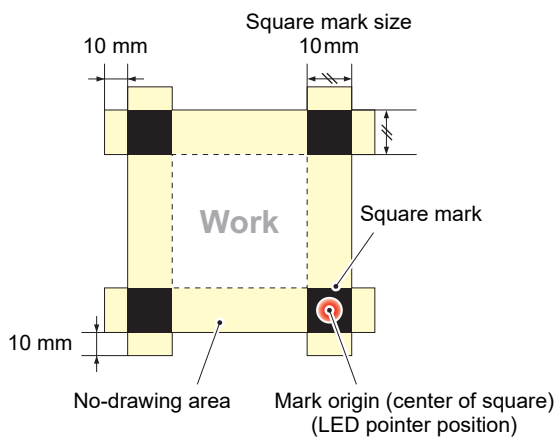

Mark Form:Type.5 (free arrangement mode/circle)

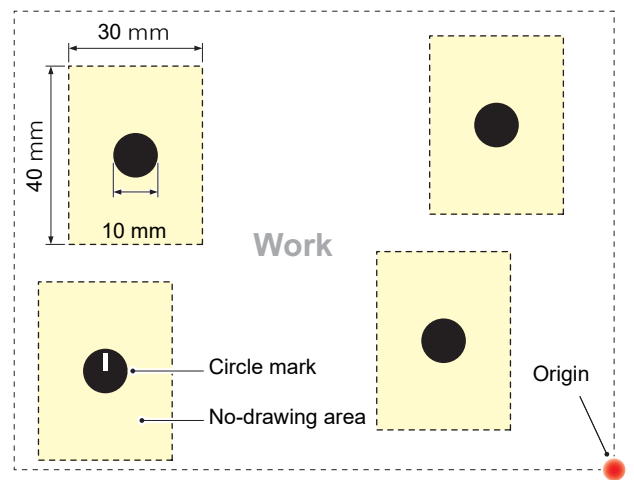

Mark Form:Type.7, (Free mode, size-specified circle)

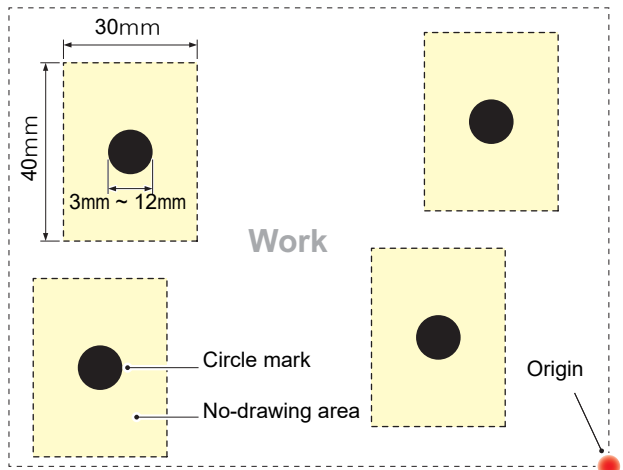

Arranging a series of register marks

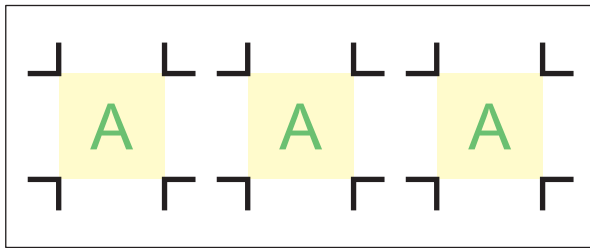

Inner/outer/square marks: Same as usual

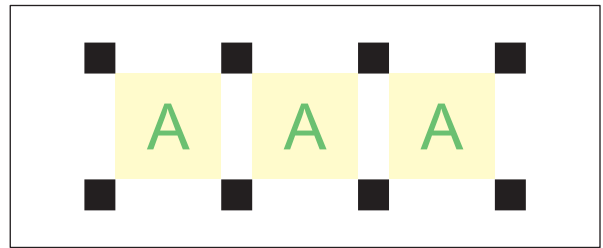

Zero margin register mark

Hint!

- Marks in a series are arranged the same as usual for inner/outer marks, square marks, and freely placeable marks. For marks without margins, the same mark serves as a left and right mark, and the same mark serves as a top and bottom mark.

Misdetection of mark origin: Example 1

From misaligned plates in offset printing

- Reproducing printing in offset printing requires the use of each plate (C, M, Y, and K). Slight plate misalignment during printing causes misalignment of printed register marks.
- When the register marks of works printed with misaligned plates are detected, the origin will also be misaligned, which will result in misaligned cutting.

Hint!

- When offset printing is used, only print a register mark from one of the CMYK plates (such as by setting the mark color to K100%). Printing a mark from a single plate eliminates concerns about plate misalignment.
- Print marks in a color that is easy to detect, accounting for the work color. (☞ P.5-9 “Register Mark Color”)

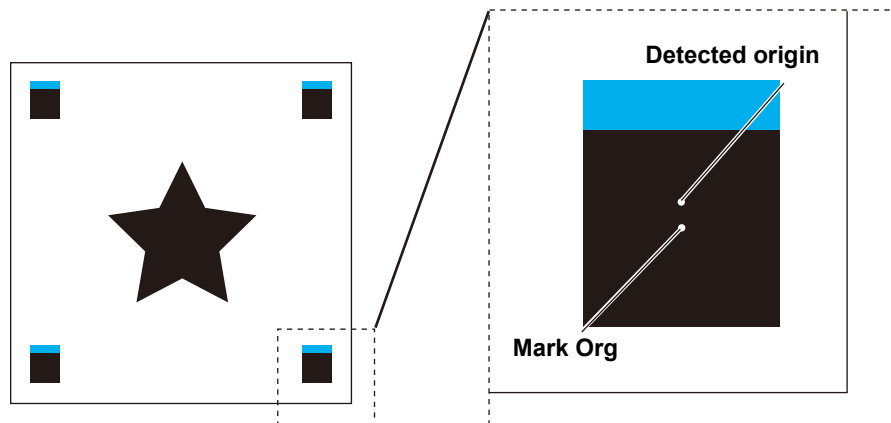

Misdetection of mark origin: Example 2

There is a risk of misdetection unless square marks are at least 10 mm apart (TP3 on Pattern A and TP1 on Pattern C, or TP2 on Pattern A and TP1 on Pattern B).

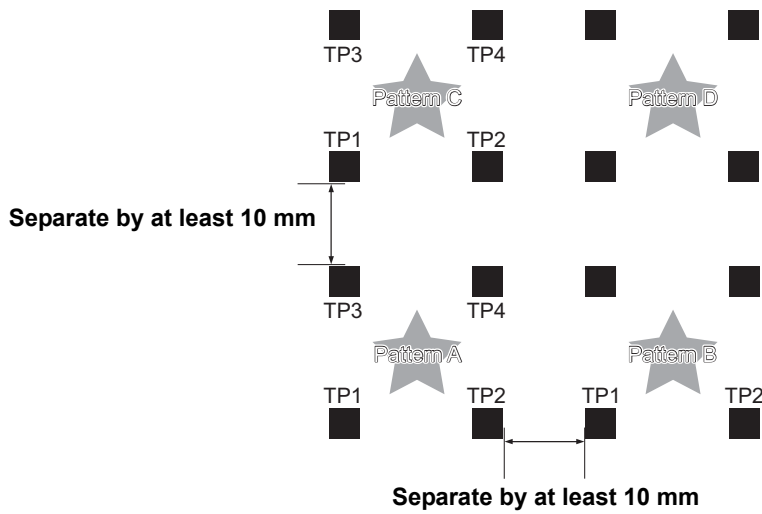

Misdetection of mark origin: Example 3

There is a risk of misdetection unless marks are separated by a distance at least as long as their length (TP2 and TP1, TP4 and TP2).

● Type.1 marks

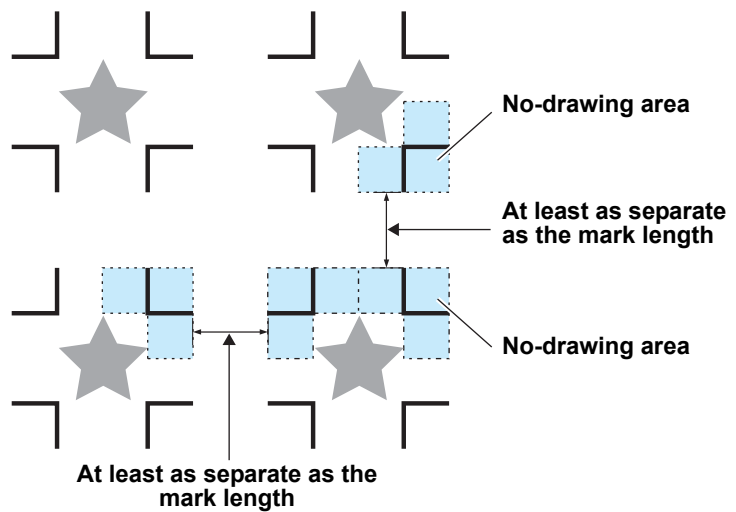

Register Mark Color

Black register marks are recommended.

Although marks in other colors can also be detected, do not use a color similar to the work color.

Confirm in advance that the color of your mark can be detected.

Additionally, marks may not be detected correctly on works that are glossy, patterned (with a hairline finish), or have certain background colors.

Black marks

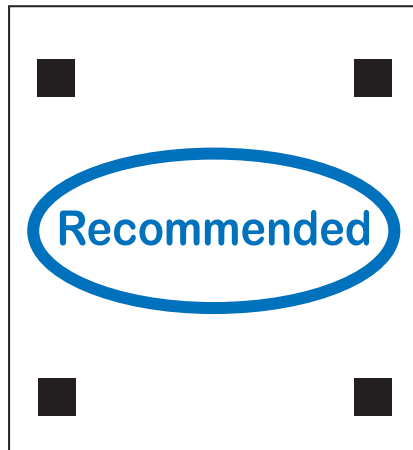

Blurry or Smudged Register Marks

With blurry or smudged marks, there is a risk of origin misdetection, which will result in misaligned cutting.



Setting Mark Detection Operation

Precautions on Mark Detection



- Once a mark is detected, the origin is set at the TP1 position (except for freely placeable marks). Using the jog keys to set the origin to another position enables that origin.

Setting list

Configure the settings as follows to cut using register marks.

Setting item	Setting value	Overview
Mark Detect	Sensor	Set this option to use the mark sensor for detection.
	Camera	Set this option to use the camera unit for detection.
	Others	Set this option to use the software that manually performs mark detection.
Data ID Code	OFF	Disables data ID code scanning after mark detection.
	ON	Scans data ID codes after mark detection.
Register mark search	OFF	Disables mark detection.
	ON	Set to ON for automatic mark searching after cutting. Also set the scan width.
Scanning width	10 to 99 cm (in 5 cm increments)	Set the scanning width in cm when mark searching is set to ON.
Media Number	Media 1 to 8	Set a media-specific adjustment value for the mark offset as needed.
After Detect Mode	Local	Switches to local mode after the mark origin detection.
	Remote	Switches to remote mode after the mark origin detection.



- When using the data ID linkage function in Continue or Toggle Mode, set the data ID code setting for mark detection to OFF. (☞ P.4-23)
- Marks are searched for only after ID cutting has ended.



- To set the mark detection to [Other].
 - (1) Set this when using the following software.
 - Software to manually detect mark while viewing camera images
 - (2) Please note that the following functions are not available
 - JOG Function Selects > Mark Origin Detection
 - JOG Function Selects > Mark Offset
 - JOG Function Selects > Camera Adjustment
 - Machine Setup > TP Detect Setup > Data ID Code
 - Machine Setup > TP Detect Setup > Search Mark
 - Machine Setup > TP Detect Setup > Media Number
 - Machine Setup > TP Detect Setup > After Detect Mode
 - Machine Setup > Continue Mode Setting > Continue Mode = Continue
 - Machine Setup > Continue Mode Setting > Continue Mode = Toggle
 - Tool Set > Cxx(Creasing roller) > Double Roller

Setting Mark Detection Operation

1 On the local mode screen, press [MENU].

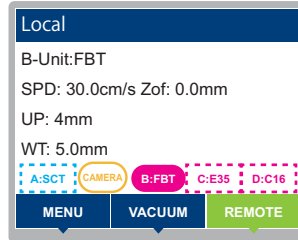

2 Press \blacktriangle \blacktriangledown to select [Machine Setup] > [TP Detect Setup] > [Mark Detect], then press the [ENTER] key.

3 Press \blacktriangle \blacktriangledown to select the setting value.

- Setting values: Sensor, Camera, Others

4 Press the [ENTER] key to confirm the setting values.

5 Press \blacktriangle \blacktriangledown to select the next setting item.

- Mark detection options are as follows.
Mark Detect / Data ID Code / Search Mark / Width / Media Number
- For details on each setting item, see P.5-10.

6 Press the [ENTER] key.

7 Press \blacktriangle \blacktriangledown to select the setting value.

- For details on the setting values for each item, see P.5-10.

8 Press the [ENTER] key to confirm the setting values.

9 To exit, press the [END/POWER] key several times to return to the local mode screen.

Automatic mark detection (corner mode marks only)

Set up automatic mark searching as follows.

With both mark detection and searching enabled, the machine searches for the next mark automatically after ID cutting.

Bidirectional scans are made over the preset scanning width from the origin after auto updating at a spacing corresponding to half the register mark size. Mark detection is then performed when lines, points, or printed objects are found.

If a square mark or the vertical/horizontal lines of other marks are detected correctly, it is recognized as a register mark, and the origin is set.

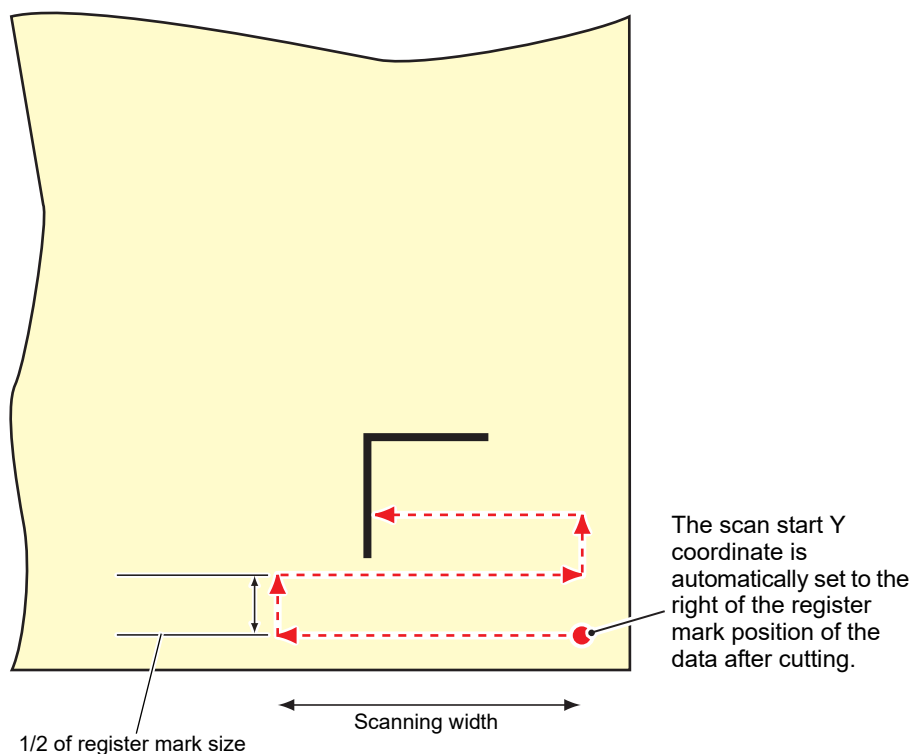

1

On the local mode screen, press [MENU].

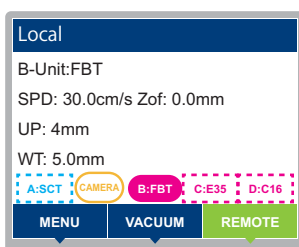

2

Press \blacktriangle \blacktriangledown to select [Machine Setup] > [TP Detect Setup] > [Search Mark], then press the [ENTER] key.

3

Press \blacktriangle \blacktriangledown to select [On], then press the [ENTER] key.

• Setting values: OFF, ON

4

Press \blacktriangle \blacktriangledown to select the width to scan, then press the [ENTER] key.

• Setting values: 10 to 99 cm

5 To exit, press the [END/POWER] key several times to return to the local mode screen.

Hint!

- Pressing the [END/POWER] key during the dragonfly search operation pauses the search. Pressing the [ENTER] key during the pause restarts the search, and pressing the [END/POWER] key aborts and ends the search.

Important!

- If no marks are recognized, a failure message is displayed for a certain time.
- Register mark search cannot be performed correctly unless the conditions are the same as those of the cut data.
 - The shape, size, color, and Y-axis coordinate of the registration mark are the same.
 - The type, thickness, and color of the workpiece are the same.
- Register mark searching cannot be performed unless mark detection is performed normally at least once after startup.
- If the search ends without finding the register mark or if the search is canceled, it will end in remote mode.
- The search range can be limited to within the workpiece using 「Cutting Area Settings」 (P.4-6). If the search goes beyond the workpiece range, it may cause a malfunction, so be sure to set the cut area according to the workpiece.

Mark Detection Camera Adjustment

Use the camera to capture an image of the work with a printed mark, and then make adjustments in the camera application.

This is performed if the camera cannot detect marks due to the type of work used or other reasons.

Hint!

- Available when an optional camera is installed.
- The camera application (OBSCURAS) must be running.

1 Set up a work with printed marks.

2 Press on the local mode screen.

- The [JOG Function Selects] screen is displayed.

3 Press to select [Camera Adjustment], then press the [ENTER] key.

- The [Camera Adjustment] screen appears.

4 Press to move the LED pointer to the mark origin.

- The head moves in each direction accordingly.
- X and Y coordinate values on the operating panel are updated.

5 Press the [ENTER] key.

6 Make adjustments in the camera application.

- To adjust image quality, refer to the camera application (OBSCURAS) instruction manual.

7

Press the [ENTER] key.

- Camera operation stops, and the machine returns to local mode.

Mark Detection Mode

The machine has detection modes for two types of register marks, as follows.

Hint!

- The detection mode is specified by a command.
- For details on settings, refer to the FineCut/Coat9 or CAMLINK2 instruction manual.

Corner mode

Marks are placed to enclose the pattern in a square area.

A number of marks from 1 to 4 is specified by command.



Corner mode (Type.1)

- The first point serves as the mark origin.
- Specifying two or more points will compensate for work skew, and specifying three or more will compensate for work shrinking and expansion and printing at the wrong size.
- ID cutting is supported (requires specifying four points).
- Choose from Type.1 to Type.4 mark shapes.
- Four points must be specified in order to use Type.4 (no margins) marks or backside cutting.

Free arrangement mode

Place any number of marks (up to 2,048) anywhere around the pattern.

The origin position is not a mark position.

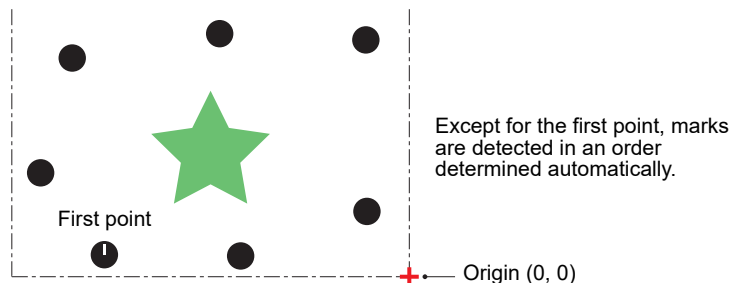

Free arrangement mode (Type.5)

- Marks must not overlap the pattern (they must be placed some distance from it).
- ID cutting is not available.
- Backside cutting with mark chips is not available (only available in corner mode).
- Type.5 and Type.7 mark shape is available, only the shape of the first point is different.
- Requires an optional camera.
- Because correction accuracy declines if fewer than four points are specified, or if they are placed far from the pattern, an appropriate number of points must be used and placed at suitable positions, based on the pattern size.
- Type.6 conforms to corner mode. (ID cutting is not possible)

Detecting the Mark Origin

The mark printed at the origin reference position is detected as the basis for setting the drawing origin. When cutting data with register marks, the mark origin detection must be performed before sending the data.

1 Set up a work with printed marks.

- For Type.5, perform mark origin detection before cutting begins to enable setting by rotating (90°, 180°, 270°) the work.

2 Press \blacktriangle \blacktriangledown \blacktriangleleft \blacktriangleright on the local mode screen.

- The [JOG Function Selects] screen is displayed.

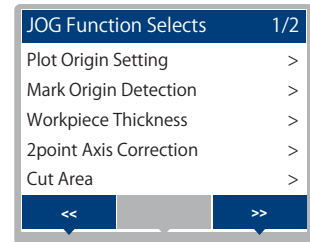

3 Press \blacktriangle \blacktriangledown to select [Mark Origin Detection], then press the [ENTER] key.

- The [Mark Origin Detection] screen appears.
- The [PLOT ORIGIN] key can be pressed to move the head to the current drawing origin. (☞ P.3-46)

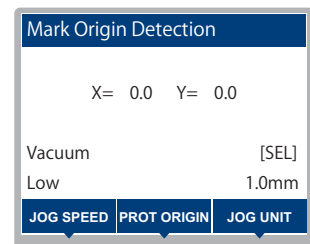

4 Press \blacktriangle \blacktriangledown \blacktriangleleft \blacktriangleright to move the LED pointer to the mark origin.

- The head moves in each direction accordingly.
- X and Y coordinate values on the operating panel are updated.

Important!

Detecting register marks

- When detecting marks on the plotter, the position for LED pointer alignment is as follows.

LED pointer position

Referring to the following figure, align the LED pointer with the indicated positions on register marks.

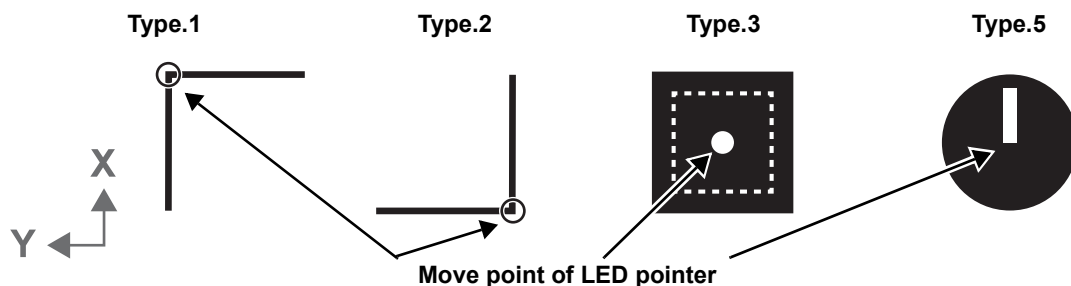

- Type.6 is at a position set by the user, so align approximately close to the mark.
- Type.7 is not supported due to its variable size. Please set the drawing origin instead. (☞ P.3-45)

5**Press the [ENTER] key.**

- The [Mark Form] screen appears.

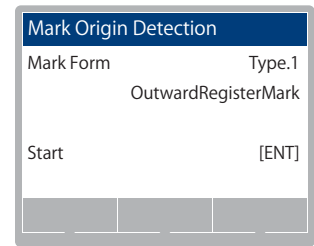
**6****Press ▲▼ to select the printed mark shape.**

- Type.1 to Type.3
- Type.5 and Type.6 are available only when a camera is connected (☞ P.5-2)

Hint!

- Type.5 and Type.6 are disabled when ID detection is enabled.

7**Press the [ENTER] key.**

- Mark detection is performed by the camera or mark sensor.

8**After normal detection, the tool is moved over the mark origin and the machine switches to local or remote mode.**

- With ID detection set to enable, ID data is automatically detected after mark detection.
- After detection, the mode can be specified. (☞ P.5-10)

9**An error screen is displayed if mark detection fails.**

- An error number and message (☞ P.8-14) is displayed.
- Press the [END] key to return to local mode.

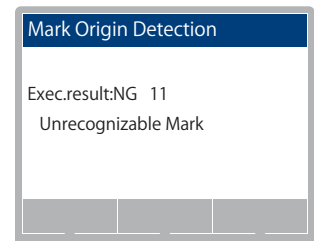

Setting Mark Origin in Teaching Mode

If the mark form Type.6 (teaching) is specified for mark origin setting, the camera can be used to set any position on printed data as the origin.

A compatible application and optional camera is required for this.

1**Select the mark form in step 6 of the mark origin setting procedure, and select Type.6.**

- Pressing [ENTER] to select the mark form launches the camera application (OBSCURAS) on the connected PC. The image from the camera is then displayed, enabling a position to be specified.

Hint!

- For details, refer to the "OBSCURAS - Function Guide".
- For details of how to use teaching mode, refer to the instruction manual for the corresponding application (such as FineCut).

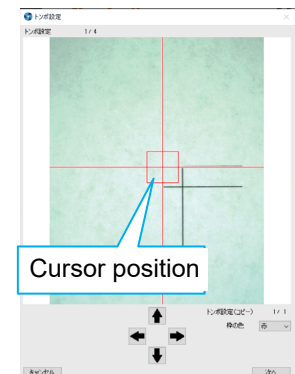

Aligning the Register Mark Detection Position

Perform offset adjustment to correct the register mark detection position. Load work on which register marks are printed.

1

Mount a pen or swivel cutter on the standard unit, then select [Tool] > [Tool Select] to select Unit A (☞ P.3-17).

- When using a pen, use the pen (SPC-0726) provided as standard.

2

Press ▲▼◀▶ on the local mode screen.

- The [JOG Function Selects] screen is displayed.

3

Press ▲▼ to select [Mark Offset], then press the [ENTER] key.

- The [Mark Offset] screen appears.
- The head moves over the cutting panel, and the LED pointer is lit.
- The media number for alignment is indicated in the upper right of the screen. (☞ P.5-10)

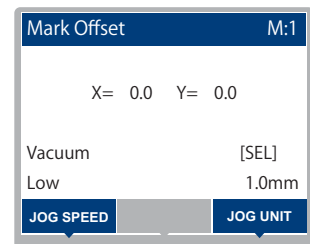

4

Press ▲▼◀▶ to move the LED pointer to the mark origin.

- The head moves in each direction accordingly.
- The LED pointer XY coordinates are indicated on the operating panel.

5

Press the [ENTER] key.

- The [Mark Form] screen appears.

Hint!

- The [Input val.] key can be pressed to allow the correction value in step 8 to be entered without drawing.

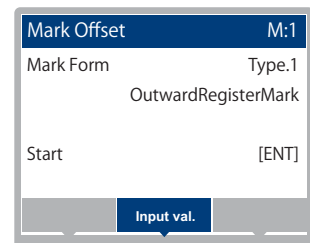

6

Press ▲▼ to select the printed mark shape.

- Type.1 to Type.3, Type.6 (☞ P.5-2)

Hint!

- The mark form for Type.4 is the same as for Type.3. Alignment is not possible with Type.5 and Type.7.

7

Press the [ENTER] key.

- After mark detection by the camera or mark sensor, a central line along the detected register mark is cut along with five secondary lines on either side, spaced 0.2 mm apart. With Type.6, use the camera application on the PC.

Misaligned by +0.2 mm from the register mark center line (indicated by - - -) in X and Y directions

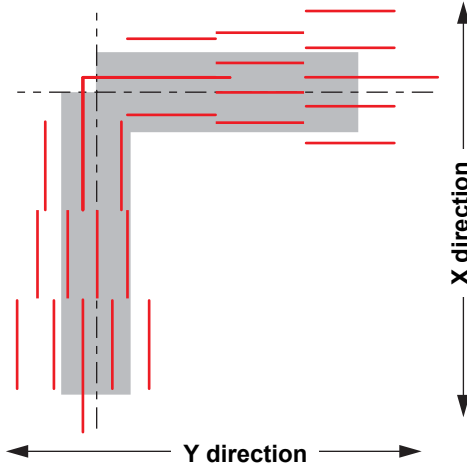

Adjusting the mark offset with a square mark

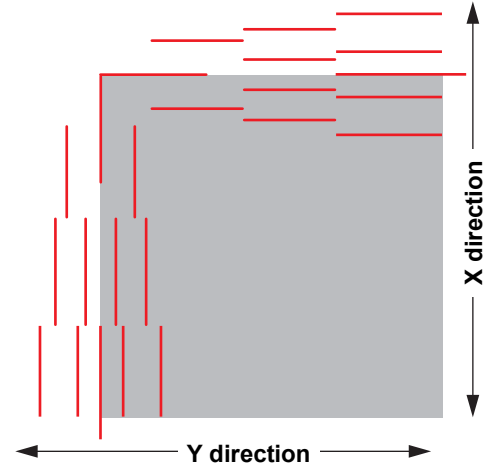

When adjusting sensor offset with teaching marks

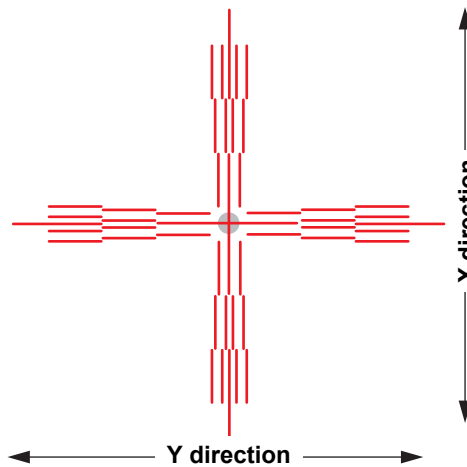

8

After drawing is complete, enter the correction value.

- Press \blacktriangle \blacktriangledown to select a setting item for input, then press the [ENTER] key.
- Press \blacktriangle \blacktriangledown to enter the correction value, then press the [ENTER] key to confirm input.
- Enter -0.2 mm for misalignment of +0.2 mm.

Mark Offset	M:1
Offset X	0.0mm
Offset Y	0.0mm

9

Press the [END/POWER] key to exit.

Continuous Cutting with Register Marks

If a work is replaced and the same data is cut after a register mark detection cut has been made, the register mark is automatically moved to the previous origin register mark position at the time of register mark detection.

In the case of free registration mark, the position of the base registration mark (First detected position) will be used. (FW v2.0 or later)

This allows continuous cutting without origin mark detection or origin setting by placing the work at approximately the same location.

To cut different data, perform origin mark detection or origin setting.

In addition, continuous cutting can be performed efficiently by utilizing the continuous cutting function of the software as follows.

Cutting with FineCut/Coat9 or CAMLINK2 cutting software enables continuous cutting of works that have only one set of marks printed on them.

Important!

- When cutting multiple images printed on a single work, select multi mode.
- If data remains in the receive buffer, the remaining data is also cut. Be sure to clear the data before continuous cutting. (☞ P.3-49 “Stopping Processing (Data Clear)”)

1

Set “FineCut/Coat9” and “CAMLINK2” then start plotting.

- (1) Select single mode.
 - (2) Set the number of times to repeat cutting.
 - (3) Select the number of register marks to detect. (“FineCut” and “Coat9” use only four detection points.)
- For details on settings, refer to the FineCut/Coat9 or CAMLINK2 instruction manual.

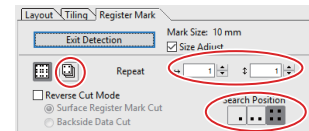

2

After cutting for the first work is finished, replace the work, align the LED pointer with the mark origin, and press the [ENTER] key.

- To cancel continuous cutting, press the [END/POWER] key.

Important!

Detecting register marks

- When detecting marks on the plotter, the position for LED pointer alignment is as follows.

LED pointer position

Referring to the following figure, align the LED pointer with the indicated positions on register marks.

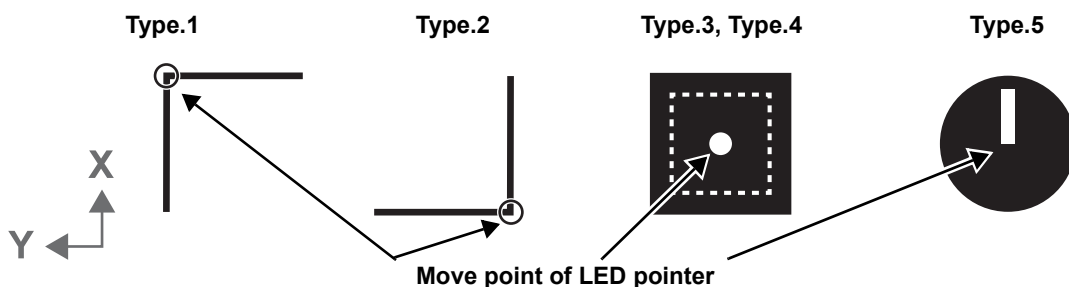

- Type.6 is at a position set by the user, so align approximately close to the mark.
- Type.7 is aligned to the center of the circle, just like Type.5.

3

Detect register marks.

- After marks have been detected, the copying process begins.
- Repeat steps 2 and 3 for the specified cutting quantity.

4

After the specified cutting quantity is complete, the machine returns to [Remote].

- Head retraction follows the setting in [Setting] > [Draw] > [Auto View]. (☞ P.1-22)

5

Linking Cutting and Printing (ID Cut)

By adding a data ID code to register marks, you can send cutting data automatically from a computer. For instructions on adding data ID code, also refer to the FineCut/Coat9 or RasterLink7 instruction manual. You can print and cut at the same time (ID cut) in conjunction with RasterLink7. For details, refer to the ID Cut Guide.

Setting Up ID Cut

1

Change the settings for scanning data ID code (☞ P.5-10).

- Enable the data ID code.

2

Set up a work.

3

Detect register marks (☞ P.5-14).

- After marks have been detected, the data ID code is scanned.
- If ID scanning fails, an error is displayed and the process is suspended.

4

After data ID code scanning, switch to remote mode.

- Cutting data is automatically sent from the computer.
- Note that cutting will begin automatically.

5

After cutting, the machine searches for the next mark.

- The time for detection is affected by the specified width and area.
- Mark detection is only possible using the sensor.

Hint!

- When data ID is used, the size of data to cut (distance between marks) must be at least about 70 mm.
- Register mark searching may not be performed correctly unless the work and mark color that were previously detected are used. In this case, manually detect the mark again.
- Enabling the data ID code setting updates the setting for mark detection when scanning IDs.

Backside Cutting Using Mark Chips

Use this function when cutting works made of materials such as corrugated cardboard that cannot be cleanly cut from the front side. This function can be combined with data ID codes. Also refer to the FineCut/Coat9 or CAMLINK2 instruction manual.

Hint! • To embed the mark chip required in backside cutting, the work must be at least 3 mm thick.

1 Set up a work.

2 Detect the mark origin.

3 Press the [REMOTE] key.
• The machine switches to remote mode.

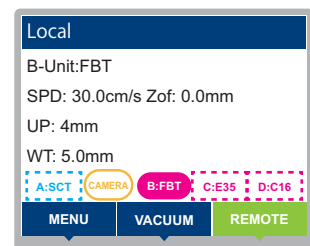

4 Send data from the host computer.
• Cutting begins automatically after the data is received.

5 Cut the diagonal of the register mark.

6 After cutting is finished, retract the head to the upper right.
• The head is retracted regardless of operation settings.
• After the head retraction, the vacuum turns off.
• To pause operation, press the [END/POWER] key.

7 Flip the work over and embed the mark chip.
• Flip the work over in the direction set in [Reverse Cut Mode] by FineCut / Coat9 or CAMLINK2 application.

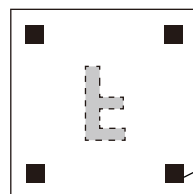
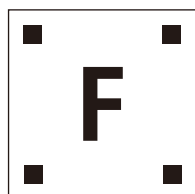

Embed the mark chip

8 Press the [ENTER] key.
• Turn the vacuum on. (If it was off before head retraction, it remains off.)
• Switch to jog mode for mark origin detection.

9

Detect the mark origin.

- Switch to remote mode after mark origin detection.
- After the mode is switched, cutting begins automatically.

10

After cutting is finished, retract the head to the upper right.

Surface Cutting Using Edge Detection

Work edges can be detected. This enables accurate cutting even when works are skewed.

Important!

- This function requires an optional camera unit and the dedicated FineCut/Coat9 or CAMLINK2 application.

1

Set up the camera in [Option Setup] (☞ P.1-26).

2

Set up edge detection operation.

- Refer to the FineCut/Coat9 or CAMLINK2 instruction manual.
- For details on settings, refer to the FineCut/Coat9 or CAMLINK2 instruction manual.

3

Set up a work with the top surface facing up (☞ P.3-45).

4

Set up FineCut/Coat9 or CAMLINK2, then start output.

- (1) Cutting is arranged.
 - (2) In [Plotter Out], set up [Edge detect].
 - (3) Click [Output].
- For details on settings, refer to the FineCut/Coat9 or CAMLINK2 instruction manual.

5

The machine automatically switches to jog mode.

6

Press ▲▼◀▶ to align the LED pointer with the lower right (edge origin) of the work.

7

Press the [ENTER] key to perform automatic edge detection and start cutting.

- Edge detection starts from the bottom right-hand corner of the workpiece and, if normal detection is achieved, the workpiece edge is detected sequentially in one X- or Y-axis location or in one XY-axis location each.
- If a corner is missing or cannot be detected normally, the corner position is automatically calculated by detecting two locations in each of the X and Y axes (when corner and X, Y axis detection is specified) if detection is specified for both X and Y axes.
- If the edge of the workpiece is not straight, the correct inclination cannot be determined and accuracy may decrease.

Hint!

- In OBSCURAS settings, if [Show the results form after edge detection] is checked, the detection result confirmation screen is displayed.
 - For details, refer to the edge detection guide and OBSCURAS function guide.

8

An error screen is displayed if edge detection fails.

- An error number and message (☞ P.8-14) is displayed.
- Press the [ENTER] key to return to jog mode.

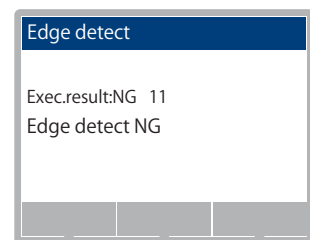

5

Backside Cutting Using Edge Detection

Register marks printed on the top surface can be detected, along with the work edge, to enable backside cutting.

Important!

- This function requires an optional camera unit and the dedicated FineCut/Coat9 or CAMLINK2 application.
- Register marks must be printed on the work.
- Unlike the corner mode in which the origin position is directly specified, the free registration mark requires the origin to be calculated from the registration mark position, which may reduce accuracy.
- If the edge of the workpiece is not straight, the correct inclination cannot be obtained and accuracy may decrease.
- When performing high-precision backside cutting on a large workpiece, we recommend cutting in corner mode using a mark chip.

1

Set up the camera in [Option Setup] (☞ P.1-26).

2

Set up edge detection operation.

- Refer to the FineCut/Coat9 or CAMLINK2 instruction manual.
- For details on settings, refer to the FineCut/Coat9 or CAMLINK2 instruction manual.

3

Set up a work with the top surface facing up (☞ P.3-45).

4

Set up FineCut/Coat9 or CAMLINK2, then start output.

- (1) Cutting of the work with register marks is arranged.
 - (2) Execute [Detect Mark].
 - (3) In [Plotter Out], set up [Reverse Cut Mode].
 - (4) In [Plotter Out], set up [Edge detect].
 - (5) In [Plotter Out], set up [Register Mark Setting].
 - (6) Click [Output].
- For details on settings, refer to the FineCut/Coat9 or CAMLINK2 instruction manual.

5

The machine automatically switches to jog mode.

6

Press ▲▼◀▶ to align the LED pointer with the lower right (edge origin) of the work.

- The [Edge detect] screen appears.

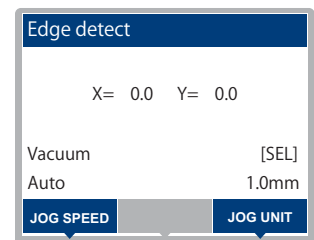

7

Press the [ENTER] key to perform automatic edge detection.

Hint!

- In OBSCURAS settings, if [Show the results form after edge detection] is checked, the detection result confirmation screen is displayed.
 - For details, refer to the edge detection guide and OBSCURAS function guide.

8**An error screen is displayed if edge detection fails.**

- An error number and message (P.8-14) is displayed.
- Press the [ENTER] key to return to jog mode.

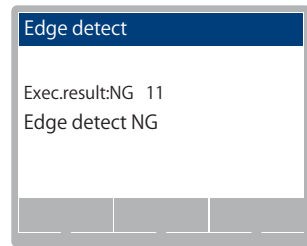
**9****The machine switches to the mark origin setting.**

- The [Mark Origin Detection] screen appears.

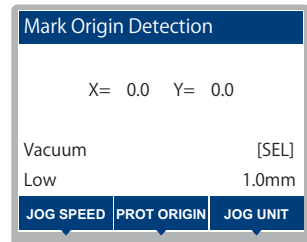
**10**

Press to move the LED pointer to the mark origin, then press the [ENTER] key.

11

Detect the mark origin.

12**Retract the head to the upper right.**

- The head is retracted regardless of operation settings.
- After the head retraction, the vacuum turns off.
- To pause operation, press the [END/POWER] key.
- The [Edge detect] screen appears.

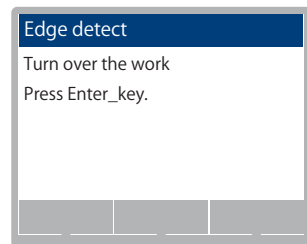
**13****Flip the work over.**

- Flip the work over in the direction set in [Reverse Cut Mode] by FineCut/Coat9 or CAMLINK2 application.

14

Press **▲▼◀▶** to move the LED pointer to the following position, then press the **[ENTER]**key.

- If the work is flipped horizontally: Lower left
- If the work is flipped vertically: Upper right

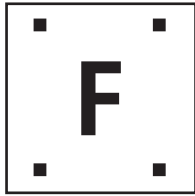

Before turning over

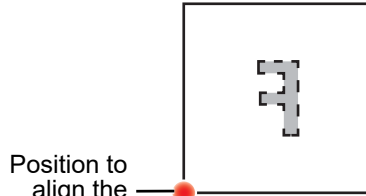

Position to align the pointer

Flipping horizontally

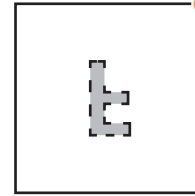

Position to align the pointer

Flipping vertically

- Edge detection begins.
- After detection, cutting begins.

Hint!

- In OBSCURAS settings, if [Show the results form after edge detection] is checked, the detection result confirmation screen is displayed.
 - For details, refer to the edge detection guide and OBSCURAS function guide.

15

An error screen is displayed if edge detection fails.

- An error number and message (👉 P.8-14) is displayed.
- Press the **[ENTER]** key to return to jog mode.

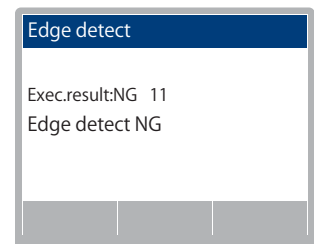

Chapter 6

Router unit R10



About this chapter

This chapter describes the router unit R10 in detail.

Mounting Tools (Router Unit).....	6-2	Machining Procedure (Router Unit).....	6-20
Attaching the router unit R10	6-2	Machining Materials for the First Time or	
Adjusting the Router Unit R10	6-11	Materials Not Listed in Recommended	
Creating Router Cutting Programs.....	6-14	Conditions	6-20
Precautions When Using FineCut	6-14	Machining Problems and Corrective Action	6-22
Materials	6-15	Basic Information on Router Machining	6-24
Note about end mills	6-16	Check and clean inside the dust collection	
Recommended cutting conditions	6-16	box.	6-26
End mill type	6-17	Check inside the dust collection box	6-26
Mounting Conditions	6-18		
End Mill and Collet Chuck Combinations and			
Positioning	6-19		

Attaching the router unit R10



- Always wear safety gloves when handling tools and end mills. Failure to observe these instructions may result in injury from the blade.
- When using the R10, confirm that the dust collector has sufficient suction. There is a risk of equipment damage or injury if the suction is too weak. (☞ P.7-8 “Dust-Collector Hose Maintenance (Only R10)”)
- Do not let liquids or grease enter the R10 air path. This may damage the equipment. The air compressor connected to R10 must be purged periodically according to the operation manual provided by the manufacturer.

Note about operating noise

When the router unit R10 is attached, high-frequency noise is emitted from the router unit electrical box when the power is turned on or when the rotation speed is changed.

This is not a fault but the operating noise from the machine, so does not affect cutting operations.

Attaching the router unit



- For safety, be sure to turn off the power to the main unit before this work. (Do not attempt mounting or removal when the power is on.)

1

Turn the main unit off.

2

Remove the station D terminal cover mounting the router unit.

- Remove the retaining screw.

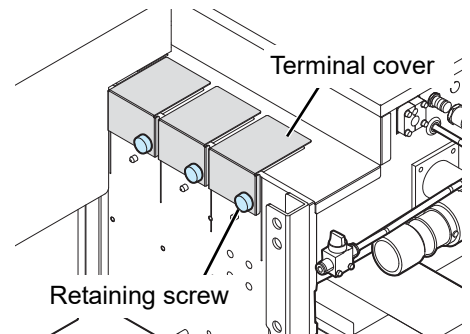

3

Using the head groove as a guide, insert the router unit into station D from above and slowly lower it.

- Fit the positioning pin (1) on the router unit into the station.
- Fit the positioning pins (2) on the station into the grooves of the router unit.



- Make sure the mounting surface is free of dust and other debris.

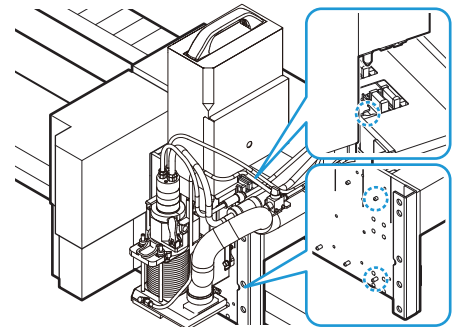

4

Using the included hex wrench, turn the two screws on the unit to secure in place.

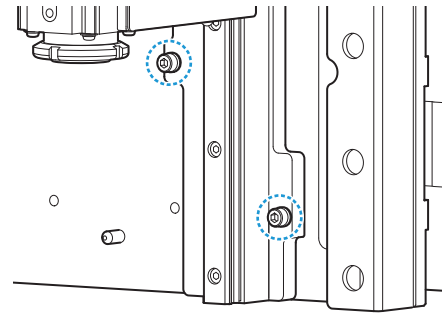

5

Connect the two spindle cables, two air tubes, and dust collector hose on the router unit to the specified locations on the side of the head.

- To connect the spindle cables, turn the locks clockwise to tighten them.
- For details on the R10 electrical box, see the following page. (🔗 P.1-9)

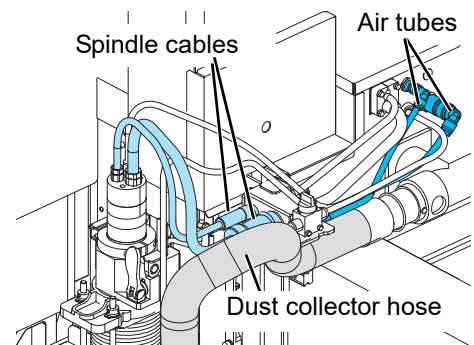

Removing the router unit

1 Turn the main unit off.

2 Using the included hex wrench, turn the two screws on the unit to remove it.

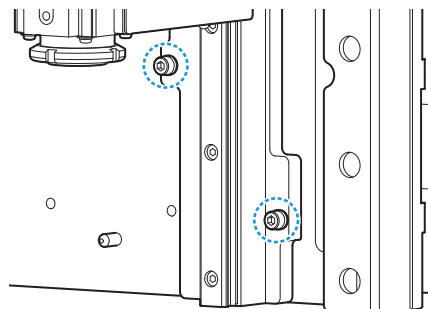

3 Disconnect the two spindle cables, two air tubes, and dust collector hose on the router unit from the specified locations on the side of the head.

- To disconnect the spindle cables, turn the locks counterclockwise to tighten them.

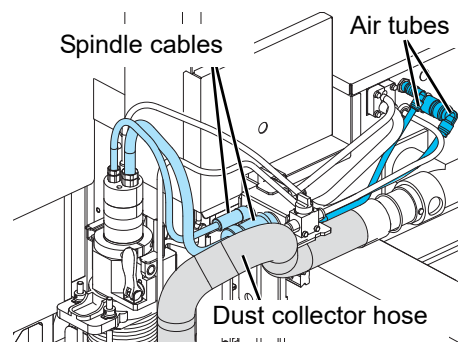

4 Pull the router unit off the station while supporting with both hands, and slowly lift it up.

- The router unit is heavy. Be sure to support it with both hands and lift it up slowly.



- Take great care when performing this task to ensure that the unit does not come into contact with the A unit or adjacent tangential units resulting in accidents.

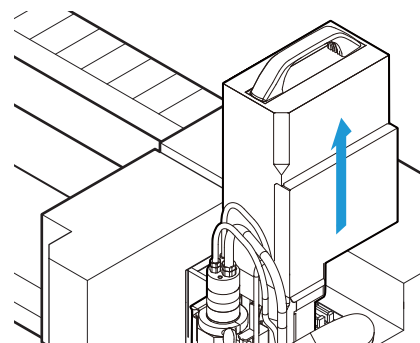

5 Mount the terminal cover to station D after the router unit has been removed.

- Secure with the retaining screw.

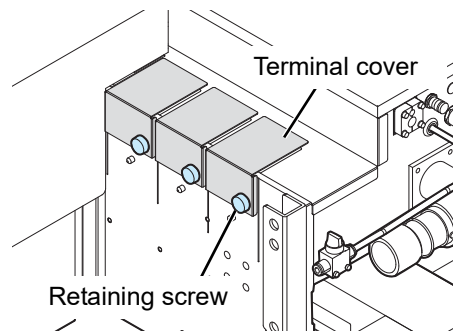

Mounting an end mill on the spindle



- Even when an end mill was replaced, be sure to use [Tool Exchange] to detect the cutting blade (P.3-14). If the procedure is not followed, there is a risk of the cutting depth changing, possibly damaging the end mill or equipment, or causing injury.
- Prepare the end mill replacement stand in advance.

1

Select [Menu] > [Tool] > [Tool Exchange].

- [Move the head to the Right edge.] is displayed. (This screen does not appear if the head is already at the right end.)

2

Press the [ENTER] key.

- The head moves to the right end.

3

Remove the two spindle cables and air tube extending from the top of the spindle.

- To disconnect the spindle cables, turn the locks counterclockwise to tighten them.

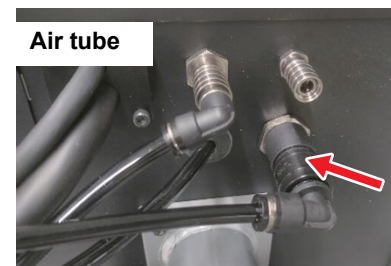
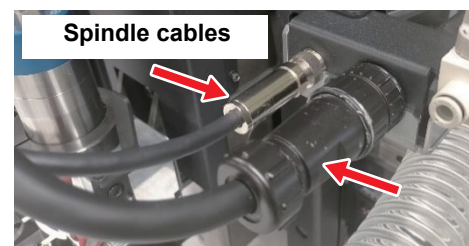

4

Pull down the red lever followed by the black lever to release the clamp.

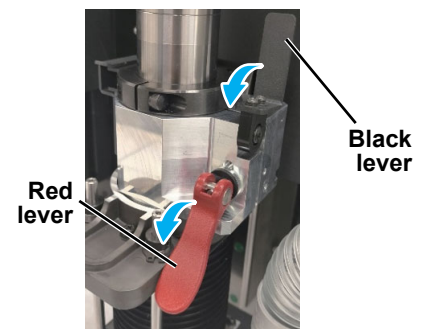

5

Turn the spindle counterclockwise to avoid the retainer, then pull it out upwards.

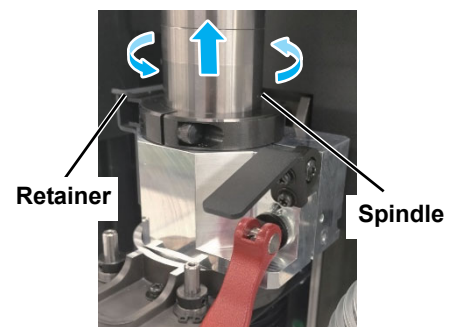

6**Set the spindle on the end mill replacement stand.****7****Place the provided 22 mm wrench or recommended torque wrench on the collet nut, then rotate counterclockwise to loosen.**

- Recommended torque wrench: SP-01007 R10 Torque wrench for spindle

Important!

- Only use tools included with the machine. Failure to observe these instructions may damage the nut.

Hint!

- Rotating the collet nut approximately one turn tightens it, and then rotating it further causes the collet chuck to open.

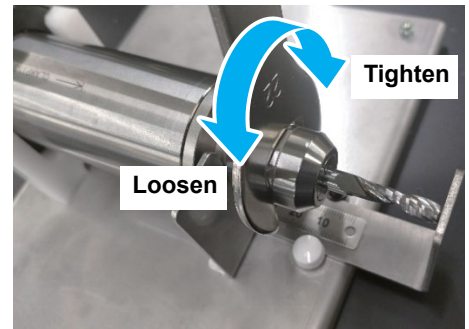
**8****Remove the collet chuck, collet nut, and end mill.**

- Remove any swarf using a compressed air gun and cotton swabs, etc.
- Also clean the tapered section of the spindle.

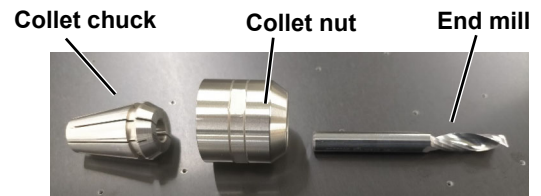
**Caution**

- Do not use a compressed air gun to clean the spindle. This may blow dust inside the spindle, leading to failure.
- Using with debris accumulated inside the grooves on the collet chuck may reduce the grip on the blade, which could damage the machine or cause physical injury. When changing the blade, be sure to check that no debris has accumulated inside the collet chuck and collet nut, and ensure that they are thoroughly cleaned before use.

**Debris accumulated in the chuck grooves****9****Reassemble the collet chuck and collet nut.****Hint!**

- Tilting the collet chuck toward the wrench gripping location makes it easier to remove and reinstall.
- When correctly assembled, the front faces of the collet chuck and the collet nut will be flush with each other.

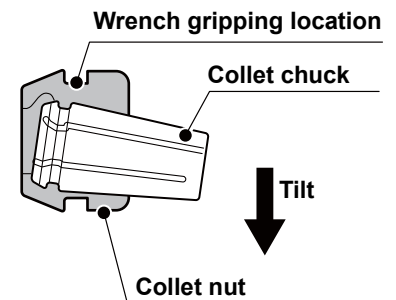
**Caution**

- Machining with the collet chuck and collet nut not correctly assembled may cause damage to the machine or injury.

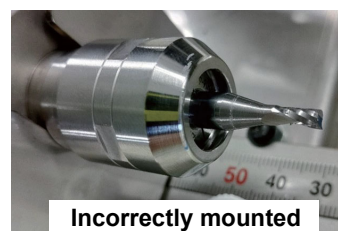
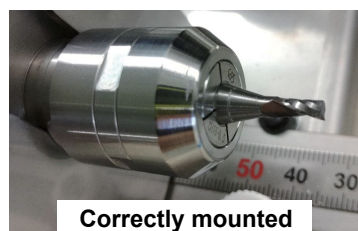

● End mill mounting procedure

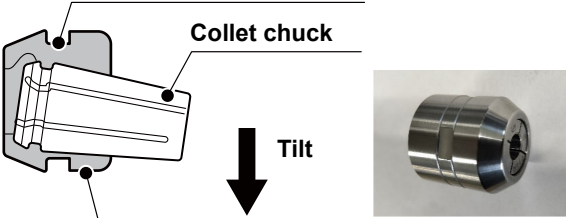
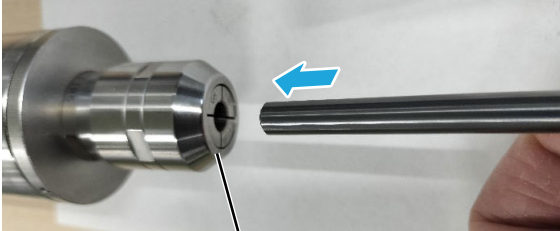
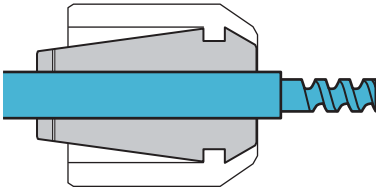
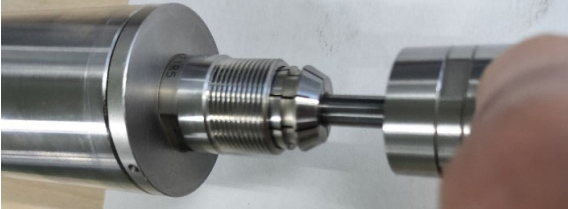
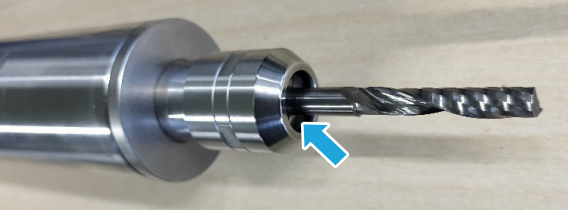
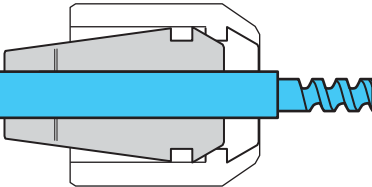

- If the end mill is not attached correctly, the grip may be insufficient, causing the end mill or collet to shift under load when machining, resulting in an uneven cutting height. Be sure to mount the end mill correctly due to the risk of damage to the spindle, end mill, as well as main unit.

Correct mounting	Incorrect mounting
<p data-bbox="242 443 719 472">Assemble the collet chuck and collet nut.</p> <p data-bbox="316 488 608 517">Wrench gripping location</p> <p data-bbox="427 539 560 568">Collet chuck</p> <p data-bbox="352 757 469 786">Collet nut</p> <p data-bbox="517 651 560 680">Tilt</p>  <p data-bbox="242 954 786 1055">Lightly screw the combined collet chuck and collet nut into the spindle. Next, insert the end mill, adjust to the specified protrusion length, then tighten the nut.</p>  <p data-bbox="288 1312 754 1364">The chuck and the nut should be almost flush with each other.</p> 	<p data-bbox="849 443 1374 495">Insert the collet chuck into the spindle. Insert the end mill, then tighten the collet nut.</p>  <p data-bbox="849 891 1426 965">A gap remains at the part shown by the arrow. Tightening in this state will damage the chuck and spindle.</p>  

10 Loosely tighten the collet chuck and collet nut on to the spindle, then insert the end mill.

- Clean each part before assembling.



11

Set the stopper position of the end mill replacement stand to suit the protruding length of the end mill attached.

- Refer to the end mill list (P.6-13).
- Machining with the end mill protruding length outside the recommended range may cause damage to the machine or injury. Be sure to check the protruding length before machining.

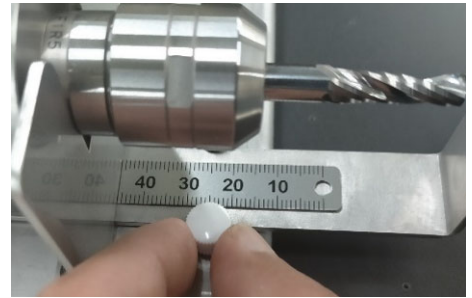

12

Push the tip of the end mill up against the stopper and tighten the collet nut by hand. Finally use a wrench to tighten fully. (Tightening torque 8 to 10 Nm)

- Recommended torque wrench: SP-01007 R10 Torque wrench for spindle
- Do not tighten without the end mill in place. This may deform the collet chuck.

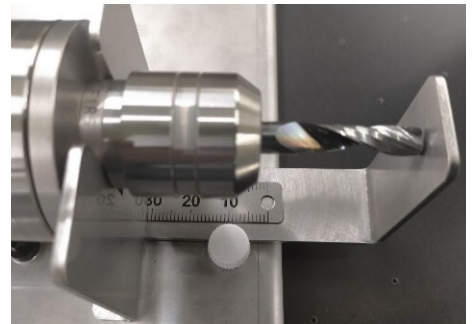

13

Move the retainer to the front, insert the spindle downward. Rotate the spindle in the clockwise direction, then move the retainer to the left.

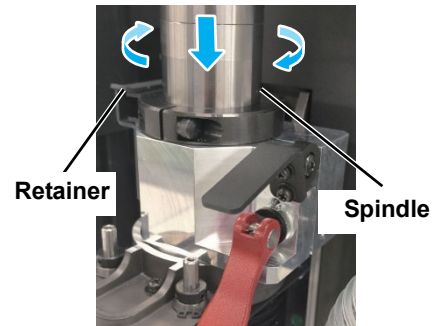

14

Push up the black lever followed by the red lever to clamp in place.

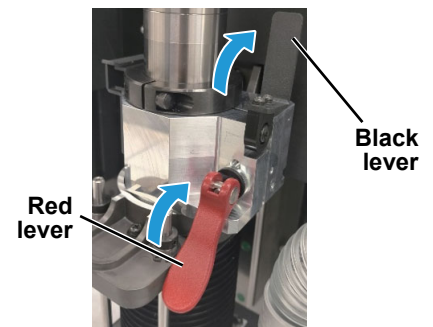

15 Connect the two spindle cables and air tube on the router unit to the specified locations on the side of the head.

- To connect the spindle cables, turn the locks clockwise to tighten them.

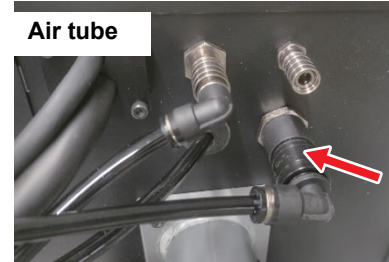
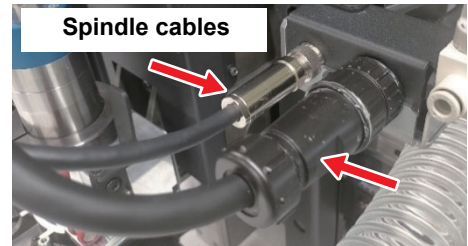

16 Once the tool has been mounted, press the [ENTER] key.

- The resetting operation starts.

17 Perform cutting edge detection (☞ P.3-14).

Cleaning the collet chuck

Clean the collet chuck each time it is removed and reattached, because it easily becomes clogged with cutting debris.

1 Referring to P.6-5 “Mounting an end mill on the spindle”, remove the collet chuck.

2 Clean with a compressed air gun.

3 Also clean the tapered mating sections on the spindle.



- Do not use a compressed air gun to clean the spindle. This may blow dust inside the spindle, leading to failure.

Adjusting the cutting tip purge air

Adjust the amount of compressed air blown onto the cutting tip during machining. (The R10 Dust Collector Box Check menu is available from firmware version 1.8.0.)



- If the amount of cutting tip purge air is insufficient, cutting dust may remain in the grooves and potentially cause equipment damage or injury during machining.

1 select [Machine Setup] > [R10 DUST BOX Check] > [Run the check].

- R10 DUST BOX Check (☞ P.6-26)

2 Press the Purge Air key and check to confirm that air blows out from the speed controller outlet.

3 Turn the speed controller knob to adjust the air discharge rate.

Hint!

- Adjust the discharge rate to suit the type of material being cut to minimize the amount of cutting dust remaining in the cutting grooves.

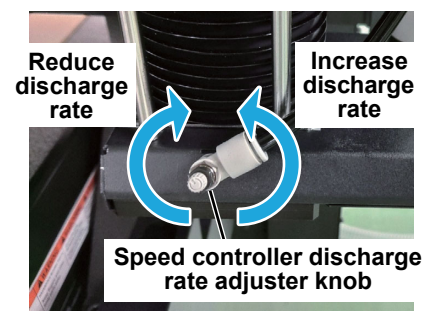

Adjusting the Router Unit R10

Offset Adjustment (Router unit)

Use the light pointer to position the test pattern cut with the router unit (R10) and adjust the offset with other tools.

Important!

- Perform this adjustment after the pen and light pointer have been aligned. (P.4-9)
- Adjust immediately after removing the unit.
- If there is no need to align with the cutting position of another tool, or if positioning for marker detection is not performed, the adjustment is not necessary again.

Hint!

- In order to align with a pointer, it is desirable to use an opaque resin-based material that can be clearly outlined when it is perforated. The material thickness should be 5 mm or less.
- The Z origin offset should be set so that the material is not cut out and the amount of cutting is about 1 to 2 mm from the surface.

Z origin offset = - (material thickness - cutting volume) * minus value
material thickness > cutting volume

1 On the local mode screen, press [MENU].

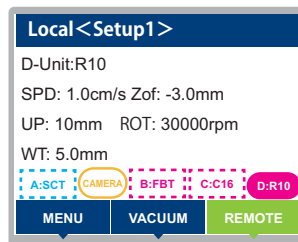

2 Press \uparrow \downarrow to select [Tool] > [Tool Adjust], then press the [ENTER] key.

3 Press \uparrow \downarrow to select a unit, then press the [ENTER] key.

- Setting values: D
- Tools currently mounted in the units are indicated.

4 Press [TEST].

5 Press \uparrow \downarrow to select [Offset Adjust], then press the [ENTER] key.

- To change the drawing position from the current position, perform the procedures described in steps 6 to 7 below.

6 Press the [SEL] key.

7 Press \uparrow \downarrow \leftarrow \rightarrow to move the head into position for drawing, then press the [ENTER] key.

8 When the confirmation screen is displayed, press the [ENTER] key.

- Cutting is executed.

9

Enter the cut line width

- (1) Select [Line width], then press the [ENTER] key to enable the width to be entered.
- (2) Press the ▲▼ keys to enter the line width.
 - Setting values: 0.1 to 6.0 mm
- (3) Press the [ENTER] key to confirm the setting value.

D-Unit: R10	
Line width	3.0mm
Adjust Point	Lower Left
Move to chosen point [F3]	
Move to	

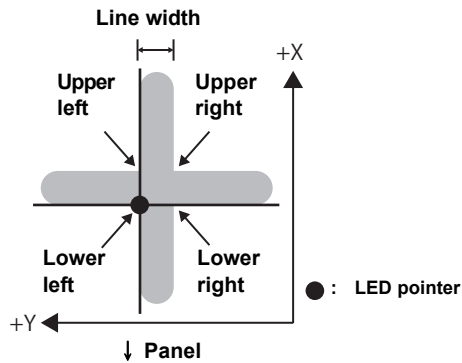

10

Select the pointer alignment position.

- (1) Select [Adjust Point], then press the [ENTER] key to enable the position to be entered.
- (2) Press the ▲▼ keys to select.
 - Setting values: Lower right, lower left, upper right, upper left
- (3) Press the [ENTER] key to confirm the setting value.

Hint!

- Check the cutting results and select a position from among the four corners of the intersection where the corner is clear and easy to align with the pointer.
- Adjust only one of the four corners. There is no need to adjust all four corners.

11

Press the [F3: Move to] key.

- The LED pointer moves to the selected position.

12

Press ▲▼◀▶ to align the LED pointer with the position selected in step 3.

- The selected "Adjust Point" is displayed at the top left of the screen.
- The [F3: JOG UNIT] key can be used to toggle the amount of movement. (0.1 mm ⇔ 1.0 mm)

Hint!

- Pressing the [END] key returns to step 9. The line width and alignment position can be altered.

D-Unit: R10	
Lower Left	
X= 0.0	Y= 0.0
Vacuum	[SEL]
	1.0mm
JOG UNIT	

13

Press the [ENTER] key to confirm the position.

- The offset value is calculated from the set position and displayed.

14 To alter the offset value set, press \blacktriangle \blacktriangledown , select [Offset X] or [Offset Y], then press the [ENTER] key. Press \blacktriangle \blacktriangledown , then enter a correction value.

- Offset X: -20.0 mm to +20.0 mm
- Offset Y: -20.0 mm to +20.0 mm
- To save, press [ENTER].
- To exit without saving, press [END/POWER].

Hint!

- If the offset X and Y values are outside the range of - 5 mm to + 5 mm, the adjustment may have failed. Perform the offset adjustment again, and confirm that the position where the pointer is aligned with the [Line Width] set in Step 9 and the [Alignment Position] selected in Step 10 are the same as the position where the pointer is aligned.

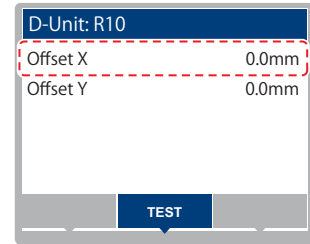

15 To end offset adjustment, press the [END/POWER] key.

Creating Router Cutting Programs

Configure the model and communication condition settings to enable communication between FineCut/Coat and the plotter. For details, refer to the “FineCut/Coat9 Reference Guide”.

Precautions When Using FineCut

Plotter/user settings

● Plotter model: Select [CFX Series (R10)].

- (👉 Refer to “Plotter/User Settings Screen” in the FineCut/Coat9 Reference Guide.)

Hint!

- If [CFX Series (R10)] is not selected, specific settings for R10, such as count cut, cannot be set.

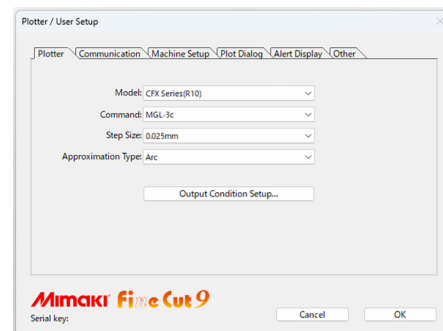

Output condition settings

● Take care to avoid incorrect units and input omissions.

- (👉 Refer to “Output Condition Settings” in the FineCut/Coat9 Reference Guide.)

Important!

- Make sure that the units for XY speed (cm/s), Z speed (mm/s), and rotation speed (1,000 rpm) are correctly set.
- Also, do not forget to enter the necessary settings, such as count cut, and joint cut.

● Acrylic (PMMA)

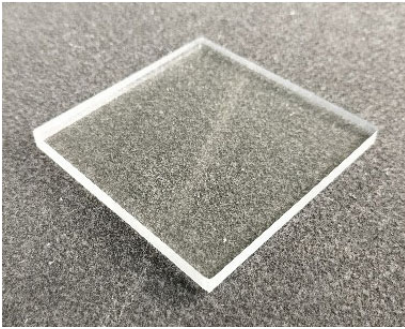

Characteristics	Depending on the manufacturing process, acrylic is available as extruded and cast material. Extruded material: Excellent board thickness dimensions. Less resistant to heat than cast material. Inexpensive. Cast material: Has a harder surface than extruded material. Often used for thicker products.
R10 machining	Up to 20 mm thick. Recommended end mills: SPB-0072, SPB-0074, SPB-0104 Easy to machine, but sensitive to heat. Use the recommended cutting conditions for the rotation speed and cutting speed.
Similar materials	Polycarbonate, polyvinyl chloride (PVC)

● Channel material (calp material)

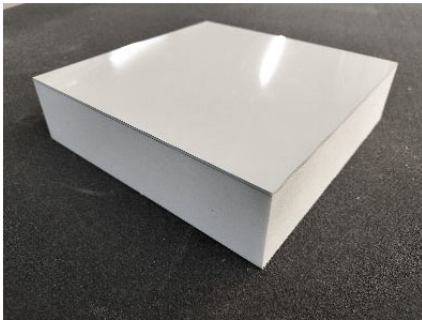

Characteristics	Foamed polyurethane resin (calcium-impregnated plastic) Sometimes includes resin sheets bonded on one or both sides.
R10 machining	Up to 54 mm thick. Recommended end mills: SPB-0069, SPB-0070, SPB-0071 Polyurethane resin is highly resistant to machining, and end mills tend to have long protrusions, therefore set lower rotation speed, cutting speed, and cutting depth than the recommended cutting conditions. The adhesive used to bond the resin sheets can be sticky, causing cutting dust to stick to the cutting tip.
Similar materials	Low foamed PVC board, polystyrene board

● MDF (Medium Density Fiberboard)



Characteristics	A material made by binding powdered wood together with adhesive. Is homogeneous and has a hard surface, unlike the fibrous, directional characteristics of wood.
R10 machining	Up to 30 mm thick. Recommended end mills: SPB-0103, SPB-0104, SPB-0105 Easy to machine, but prone to scorching, therefore do not exceed the maximum rotation speed for a $\phi 6$ end mill: 30,000 rpm. The adhesive impregnated in MDF is heat-sensitive and sticky. If cutting dust is difficult to collect, reduce the cutting depth and increase the number of cuts to improve cutting quality.
Similar materials	Particle board Natural wood tends to splinter along the fibers, causing material cracking and cutting dust clogging.

● Aluminum composite sheet



Characteristics	Consists of polyethylene resin (PE) sandwiched between aluminum sheets. Excellent light weight and strength.
R10 machining	Up to 5 mm thick. Recommended end mills: SPB-0067, PB-0072, SPB-0074 Easy to machine. The resin layer is heat-sensitive and bonded, so care is required when selecting the rotation speed. If melting occurs, reduce the rotation speed.
Similar materials	Aluminum sheet (up to 1 mm thick)

● Materials that cannot be machined

Machining rubber, natural wood, leather, and fabric is dangerous as the material or fiber debris can easily wrap around the cutting tip.

Materials such as steel and thick aluminum sheet generally require wet machining using cutting oil, and cannot be machined dry.

Sponge and polystyrene foam are too soft, causing the material to shift and resulting in poor machining quality.

Note about end mills

Standard end mills are provided that meet the mounting conditions and offer optimum machining quality and throughput.

It is not recommended to machine using conditions that deviate significantly from the recommended cutting conditions.

Use end mills suitable for the material to be machined and under the appropriate conditions.

Recommended cutting conditions

Material type	Thickness (mm)	End mill type	Cutter diameter (mm)	Cutting direction	Count cut (cycles)	End mill rotation speed (1000rpm)	Machining speed (cm/s)	Cutting depth per time(max) (mm)	Z speed (mm/s)
Resin sheet	0 ~ 5	SPB-0067	3	Up-cut	1	30	3	5	10
Aluminum composite sheet	0 ~ 5	SPB-0068	3		1	30	2	5	10
Channel material	0 ~ 15	SPB-0069	4		2 ~ 3	30	1	6	10
	15 ~ 30	SPB-0070	6		2 ~ 3	30	1	10	10
	30 ~ 54	SPB-0071	6		3 ~ 6	30	1	10	10
Acrylic material	0 ~ 3	SPB-0074	3		1	40	10	3	10
	0 ~ 5	SPB-0072	4		1	40	10	5	10
	5 ~ 10	SPB-0103	6		2 ~ 5	30	10	2	10
	10 ~ 20	SPB-0104	6		5 ~ 10	30	10	2	10
MDF	0 ~ 10	SPB-0103	6		1 ~ 2	30	5	5	10
	10 ~ 20	SPB-0104	6		2 ~ 4	30	5	5	10
	20 ~ 30	SPB-0105	6		4 ~ 6	30	5	5	10

- When cutting multiple times, setting the cutting depth per cut shallower will improve smoothness.
- If you want to improve the smoothness of the machined surface, set a slower cutting speed.

End mill type

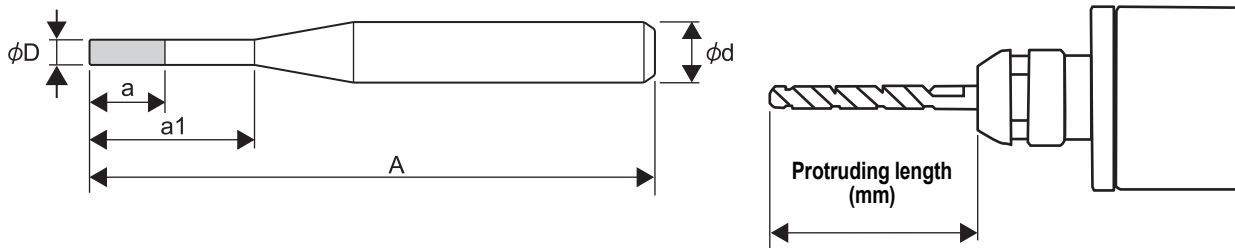

End mill type	No. of cutting blades	Cutter diameter (φ D)	Cutter length (a)	Effective length (a1)	Overall length (A)	Shank diameter (φ d)	Protruding length (mm)	Max. rotation speed (× 1,000 rpm)	Groove cutting depth (mm)	Side face cutting depth (mm)
SPB-0067	2	φ 3	9 mm	-	60	φ 6	21	40	1.5	4.5
SPB-0068	2	φ 3	12 mm	-	50	φ 6	23	40	1.5	4.5
SPB-0069	2	φ 4	8 mm	24 mm	70	φ 6	36	30	2	6
SPB-0070	2	φ 6	12 mm	42 mm	80	φ 6	46	30	3	9
SPB-0071	2	φ 6	12 mm	63 mm	120	φ 6	66	30	3	9
SPB-0072	1	φ 4	8 mm	-	50	φ 6	16	40	2	6
SPB-0074	1	φ 3	6 mm	-	50	φ 6	16	40	1.5	4.5
SPB-0103	1	φ 6	12 mm	-	50	φ 6	21	40	3	9
SPB-0104	1	φ 6	22 mm	-	58	φ 6	31	40	3	9
SPB-0105	1	φ 6	32 mm	-	100	φ 6	46	30	3	9

Cutting conditions

- Enter the value in Main Unit > Tool Set, referring to the Recommended cutting conditions table. (P.6-16)
- Be sure to set the tool protrusion length to be at least the maximum cutting depth in the processing data + 10 mm (see [Protrusion Length] in the figure above for details).
If the protrusion length is insufficient, an [INFORMATION c6d: Offscale] error will occur (P.8-10).
Cutting depth is limited and may not cut through.

Mounting Conditions

End mills that do not meet the following conditions cannot be used:

- The shank diameter (straight section) must be $\phi 6 0/-0.01$.
Be sure to insert only the straight section into the chuck.
- The protruding length from the front end of the collet chuck must be between 16 and 66 mm.
Correct operation will not be possible outside this range.
- The protruding length from the rear end of the collet chuck must be between 0 and 43 mm.
Exceeding this range will damage the spindle or collet chuck.
- Machining is not possible with incomplete cutting edges.
To improve cutting dust discharge, set the cutting depth to less than the cutter length.

<For effective length type end mills>

- The maximum material thickness that can be machined is the same as the effective length.

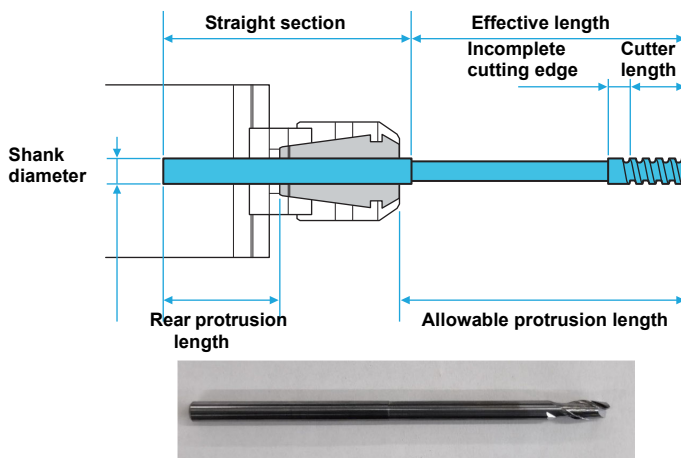

<For full flute type end mills>

- The maximum material thickness that can be machined is the cutter length.

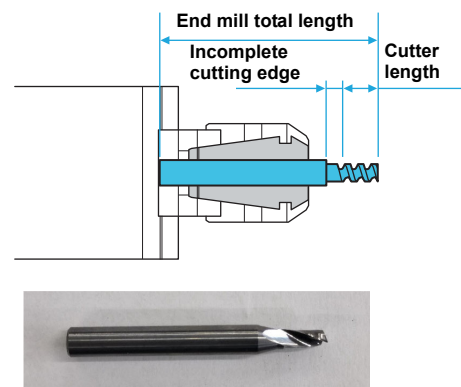

End Mill and Collet Chuck Combinations and Positioning

Some end mills cannot be used, depending on the individual dimensions of the end mill and collet chuck.

NG Cutting section is chucked.

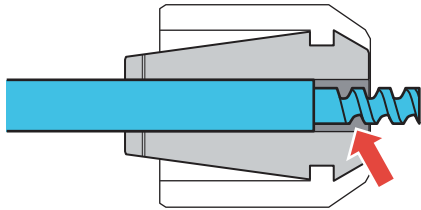

NG Straight section is shorter than chuck length.

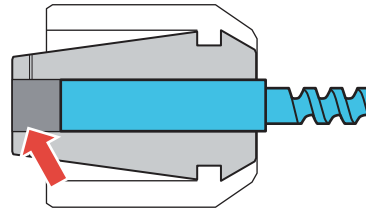

NG Protruding length is less than 16 mm.

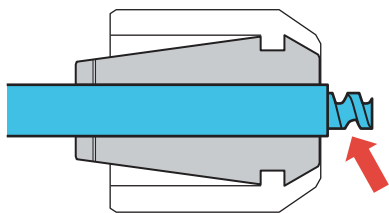

NG Protrudes more than 43 mm from rear of collet chuck.

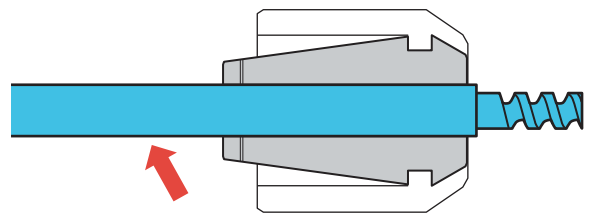

NG Protruding length exceeds 66 mm.

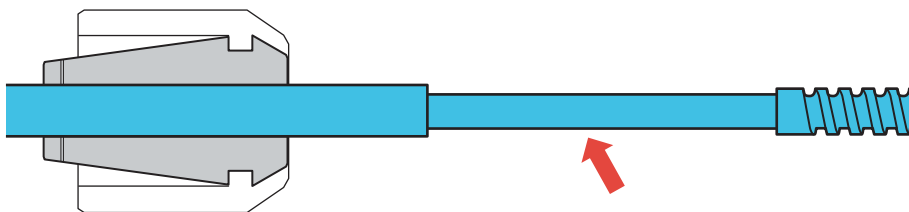

OK Correct combination

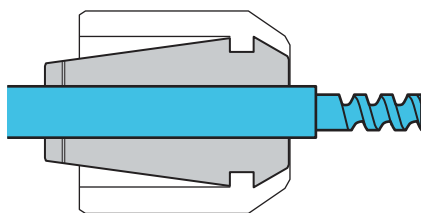

Machining Materials for the First Time or Materials Not Listed in Recommended Conditions

When machining a material for the first time or when using materials not listed in the recommended conditions, machine in accordance with the following procedure.

● Machining procedure

1 Select and mount an end mill suitable for the material and thickness

2 Create a cutting program using FineCut

- Be sure to enter the necessary details, such as count cut, cutting direction, and joint cut.

3 Perform a dry run using the CFX main unit

- Check and adjust the created cutting program before setting the material.

4 Set the material

5 Machine the material

Machining procedure

1

Select and mount an end mill suitable for the machining

- Select an end mill referring to the table. (☞ P.6-13)
(To machine 20 mm thick polyurethane foam material, select end mill SPB-0070.)
- Mount the end mill correctly referring to the end mill mounting instructions. (☞ P.6-5)

2

Create a cutting program using FineCut

- For details, refer to the “FineCut/Coat9 Reference Guide”.

Hint!

- Start with a cutting depth corresponding to half of the end mill cutter diameter. (For a $\phi 6$ cutter, set a cutting depth of 3 mm.)
- Refer to P.6-16 “Recommended cutting conditions” and start with the lowest settings.
If the rotation speed and speed are set too low, this may cause poor cutting quality or melt the material. Use the values provided in the table.

3

Perform a dry run using the CFX main unit

- Check and adjust the created cutting program before setting the material.



- Be sure to wear the safety glasses provided when observing cutting operations.

Hint!

- With thin materials, the cutting tip of the end mill may be difficult to observe due to being hidden behind the dust collector brush. In such cases, for FineCut, enter a thicker (5 to 10 mm) media thickness (material thickness) than the actual thickness to raise the bottom position of the dust collector brush, making it easier to observe the cutter. (Be sure to revert to the original setting after checking.)

4**Set the material****Hint!**

- When using an underlay sheet, select “Main Unit” > “Tool Set” > “Underlay Sheet” and set it to “Use”. Then, enter the sheet thickness. The sheet is adhesive, so first lay the sheet, then place the material on top of it directly from above.
- For materials like calp where the resin sheets on the front and back differ, place the harder or thicker side facing up for easier cutting and reducing the dust discharged.



- If the material has a protective film or paper attached to the surface, it may peel back or tear significantly during machining. Pieces torn off may also clog the dust collector hose. Therefore, before starting machining, be sure to remove any protective material on the upper surface of the material.

5**Machine the material****Hint!**

- If no issues were observed with machining, gradually increase the cutting depth to reduce the machining time. (The upper limit is 1.5 times the cutter diameter or the cutter length, whichever is shorter.) Alternatively, increase the XY speed without changing the cutting depth. (The upper limit is 1.5 times the recommended speed.)
- If issues were observed during machining, refer to “Machining Problems and Corrective Action”.

Machining Problems and Corrective Action

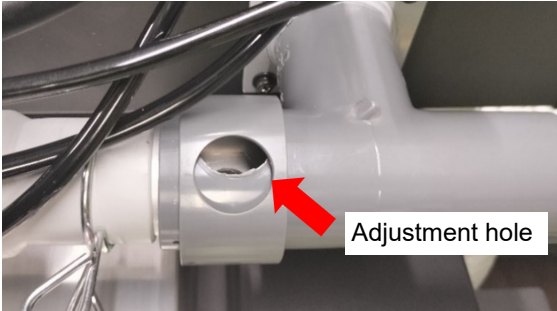
Issue	Cause and corrective action
The cutter does not cut through or cuts too deeply.	<ul style="list-style-type: none"> • There is a problem with the cutting program. • Adjust the Z offset. (A positive value increases the cutting depth.) • The material is warped or not adhering to the surface. • The end mill is not correctly chucked. The end mill is loose. Refer to  P.6-7 "End mill mounting procedure".
Cutting dust scatters.	<ul style="list-style-type: none"> • There is a gap between the dust collector brush and the material surface. → Adjust using the brush offset. • When the material is thick or the cutting grooves are deep, dust scatters along the grooves. This is normal.
Cutting dust clogs.	<ul style="list-style-type: none"> • Check the suction power of the dust collector. → Disconnect the hose from the dust collector outlet and check by hand. • Check the suction power of the dust collector brush outlet. → Run the dust collector and check by hand. • Pieces of protective film or the material may have been sucked inside the dust collector brush. → 1. Remove the protective film. 2. Secure small pieces in place with tape during joint cutting. 3. Open the adjustment hole on joint H on the side of the slider to adjust the suction power. <div data-bbox="837 902 1396 1211" style="text-align: center;">  <p>Adjustment hole</p> </div> <ul style="list-style-type: none"> • Dust is starting to melt and form clumps. → Reduce the rotation speed. Increase the XY speed.
Machining is noisy or chattering occurs.	<ul style="list-style-type: none"> • Chattering is more likely with longer end mill protrusions (30 mm or more). → Reduce the XY speed. Reduce the cutting depth. • The R10 unit mounting screws or spindle clamp are loose. → Tighten sufficiently. • The cutting tip is chipped. Cutting dust is fusing to the cutter. → Clean or replace the end mill.
I want to improve the cutting quality of the cut face.	<ul style="list-style-type: none"> • Striations remain on the cut face. → Increase the rotation speed. Reduce the XY speed. Replace the end mill. • Cutting dust is fusing to the cutter. → Reduce the rotation speed. Increase the XY speed. If using a double-flute end mill, replace with a single-flute end mill. • Speckled patterns are left on the material. The material is whitening. (Acrylic) → Reduce the XY speed. Replace the end mill. • The material is starting to melt (resin), or scorch (MDF). → Reduce the rotation speed. Increase the XY speed.
I hear a sound as if the rotation is slowing down during machining.	<ul style="list-style-type: none"> • Occurs during plunge cutting. → Reduce the Z speed. Reduce the cutting depth. • Occurs during groove cutting. → Poor cutting dust discharge. Reduce the XY speed. Reduce the cutting depth.

Issue	Cause and corrective action
The end mill cutting tip is chipped or broken.	<ul style="list-style-type: none"> • Damaged during groove cutting. → Reduce the cutting depth. Reduce the XY speed. • Damaged during plunge cutting. → Reduce the Z speed. • Calp material → Calp has the highest machining load of resin materials, therefore do not exceed the recommended cutting depth conditions. Full-flute end mills are susceptible to breakage, therefore be sure to use an effective-length end mill.
The layer lines from multiple cuts are noticeable.	<ul style="list-style-type: none"> • Calp → The cutting tip is vibrating. → Clean or replace the collet chuck and end mill. • Acrylic → The cutting tip is chipped. Cutting dust is fusing to the cutter. → Clean or replace the end mill. • The material may have shifted during machining, therefore secure it in place with tape if necessary.

Basic Information on Router Machining

Groove cutting

Groove cutting subjects the machine to a higher machining load and has poorer cutting dust discharge compared to side machining. Therefore, avoid exceeding the recommended cutting conditions. This can cause double cutting of cutting dust and other adverse effects.

Up-cut/Down-cut

With this unit, the left side relative to the end mill cutting direction forms the up-cut, and the right side forms the down-cut. Perform test cuts to decide which side should be used for the product side. Generally, up-cutting provides better machining quality, while down-cutting results in lower tool wear and longer tool life.

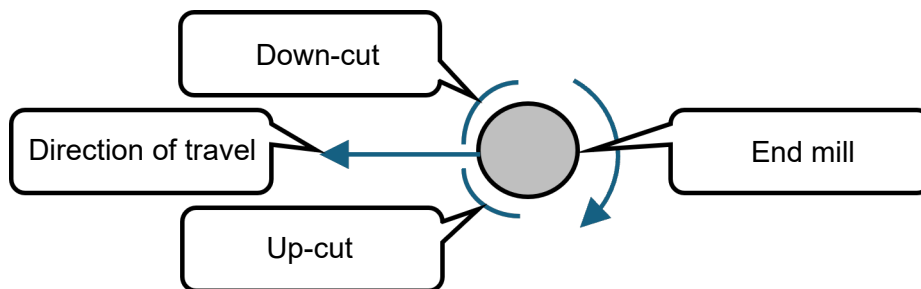

Cutter length

The cutting edge has a smaller cross-sectional area and lower strength, therefore as a rule the cutting depth (machining depth) should not exceed the cutter diameter. Even if the cutting edge is long, machining beyond this limit can cause loud chattering or increase the risk of tool breakage. Machining using the full length of the cutting edge also results in poor cutting dust discharge and reduced machining quality. Allow for an adequate margin when setting the cutting depth.

Example of an end mill with a long cutting edge



No. of cutting blades

Single-flute end mills have excellent cutting dust discharge, while double-flute end mills offer better rotational balance, making them more suitable for high-speed rotation. In resin machining, single-flute end mills generally allow more consistent and higher-quality machining.

Plunge cutting

Unlike drills, end mills are not well-suited to plunge cutting (machining in the Z direction). Use an end mill designed for plunge cutting and set the Z speed to about one-fifth to one-tenth of the XY speed.

Helical twist angle

End mills typically have helical flutes. End mills with almost straight flutes are intended for side face finishing. They have a high cutting resistance and are not suited to groove cutting or plunge cutting.

Cutting edge chipping and cutting tip geometry

When the cutting edge becomes chipped or worn, or when cutting dust adheres to the cutting edge, this increases machining noise and reduces quality. Use a magnifying glass to check the cutting edge, and clean, wash, or replace if necessary.

Unused end mill



End mill with chipped cutting edge



Cutting composite boards and MDF

When cutting materials with laminated resin sheets such as aluminum composite sheet or calp material, or materials made of compacted wood dust such as MDF, adhesive tends to adhere to the end mill. The end mill should therefore be cleaned as necessary.

Protrusion length

Doubling the protrusion length reduces the stiffness of an end mill to one-eighth, increasing the risk of chattering and breakage. Reduce both the rotation speed and cutting depth. The maximum rotation speed for protrusion lengths over 30 mm is typically 30,000 rpm.

Count cut

With calp materials or MDF, the surface and internal layers may have different properties or hardnesses. As a long end mill is used with multiple passes, using the same cutting conditions can cause chattering, reduced quality, and end mill breakage. Machine by optimizing the cutting depth and speed individually for each layer.

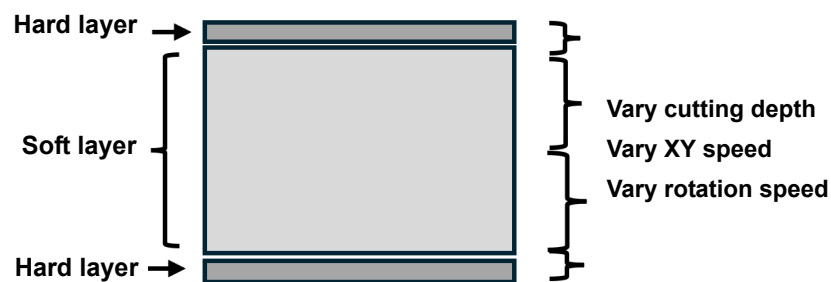
Throughput

With calp materials or MDF, the surface and internal layers may have different properties or hardnesses. As a long end mill is used with multiple passes, using the same cutting conditions can cause chattering, reduced quality, and end mill breakage. Machine by optimizing the cutting depth and speed individually for each layer.

Check and clean inside the dust collection box.

If you continue cutting with chips and other debris accumulated in the router unit's dust collection box, the following problems will occur.

- The chip collection ability will decrease.
- Cutting debris will wrap around the blade, causing abnormal operation.

Check the inside of the dust collection box regularly and remove chips and other debris.

(The following "R10 Dust Collection Box Check" function is available from firmware version 1.8.0 onwards.)

Check inside the dust collection box

- 1 On the local mode screen, press [MENU].

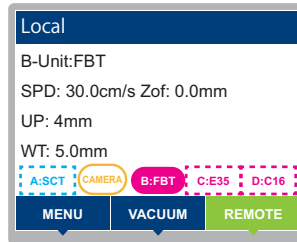

- 2 Press \triangle ∇ to select [Machine Setup], then press the [ENTER] key.

- 3 Press \triangle ∇ to select [R10 Dust Collector Box Check], then press the [ENTER] key.

- 4 Press \triangle ∇ to select [Check], then press the [ENTER] key.

- If no router unit is installed in the D-station, a warning message is displayed and cannot be performed.

- 5 The display indicates that the head is to be moved to the evacuation point at the bottom right.

- If there are any obstacles when moving, remove them before pressing [ENTER].

- 6 If the spindle is mounted, an illustration showing the location to be checked is displayed.

- After checking, press the [F3:NEXT] key or the [ENTER] key.
- If the spindle is not installed, go to step 7.

- 7 Check the inside of the dust collection box and remove chips, etc. (☞ P.7-8)



- If a spindle is fitted, the end mill is hidden inside the dust collection nozzle. Work carefully to keep hands and other objects away from the blade.

Hint!

- Each air equipped inside the dust collection box can be switched on and off.
 - [F1: PURGE AIR] : Blade edge purge air.
 - [F3: CLEANER]: dust suction air

- 8 To exit, press the [END/POWER] key several times to return to the local mode screen.

Setting the display interval for warning guidance



- Guidance is displayed periodically at startup so that you can periodically check the inside of the dust collection box. After the initial startup operation is complete, if the period for displaying the guidance has elapsed, the guidance shown on the right will be displayed (only if a router unit is installed in the D station).
 - Press [ENTER] key to proceed to check execution of the R10 dust collection box.
 - Press [END] key to return to the local screen without proceeding to the R10 dust collection box check (the timing for displaying the next guidance will be updated).
- If you want to change the period for displaying the guidance, change the settings using the following procedure.

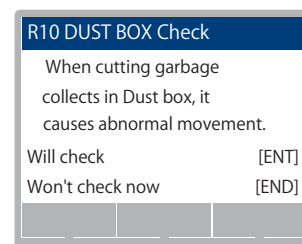

1 On the local mode screen, press [MENU].

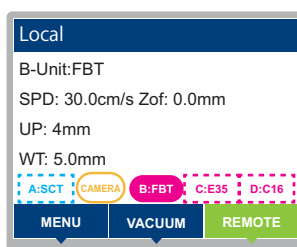

2 Press ▲▼ to select [Machine Setup], then press the [ENTER] key.

3 Press ▲▼ to select [R10 Dust Collector Box Check], then press the [ENTER] key.

4 Press ▲▼ to select [Check interval], then press the [ENTER] key.

5 Press ▲▼ to select [Check interval] setting.

- Set value: OFF, 1 day, 3 days, 7 days
- Default value: 1 day

6 Press the [ENTER] key.

- The entered value will be registered. At the same time, the date and time for the next guidance display will be updated.
- If you do not want to register the value, press the [END/POWER] key.

7 To exit, press the [END/POWER] key several times to return to the local mode screen.

Chapter 7

Routine Maintenance



About this chapter

To ensure years of precise performance, maintain the machine periodically based on the frequency of use.

Read the maintenance precautions thoroughly before maintaining this product.

Routine Maintenance	7-2	Cleaning the Mark Sensor/Y-Bar Rail	7-7
Cutting Panel Surface	7-2	Dust-Collector Hose Maintenance (Only R10)	
Operating Panel Surface	7-2	7-8
Covers	7-2	Cleaning with Auxiliary Air (Only R10)	7-9
Cutter Blade Maintenance	7-2	Cleaning the Router Blade	
Units	7-3	(End Mill) (Only R10)	7-9
Cleaning the Vacuum Filter	7-5		
Cleaning the Camera Unit	7-6		
Cleaning the Photoelectric Sensors and LED			
Pointer	7-6		

Routine Maintenance

Regular cleaning is recommended to keep the machine in good working order.



- Do not use abrasive detergents or thinners. These may deform covers and the cutting panel.

Cutting Panel Surface

Clear any clogged suction holes by inserting a thin wire. The dislodged material will be discharged through the vacuum exhaust port.

For light soiling, wipe with a clean, dry cloth. For heavier soiling, wipe after moistening a clean, dry cloth with a small amount of alcohol.



- Do not allow liquids to get inside the machine. Otherwise there is a risk of failure, electric shock, or fire.

Operating Panel Surface

If cutting dust or debris adheres to the panel, use a vacuum cleaner or similar appliance with a brush nozzle to remove the dust and debris from the panel.

Covers

For light soiling, wipe with a clean, dry cloth. For heavier soiling, wipe after moistening a clean, dry cloth with a small amount of alcohol.

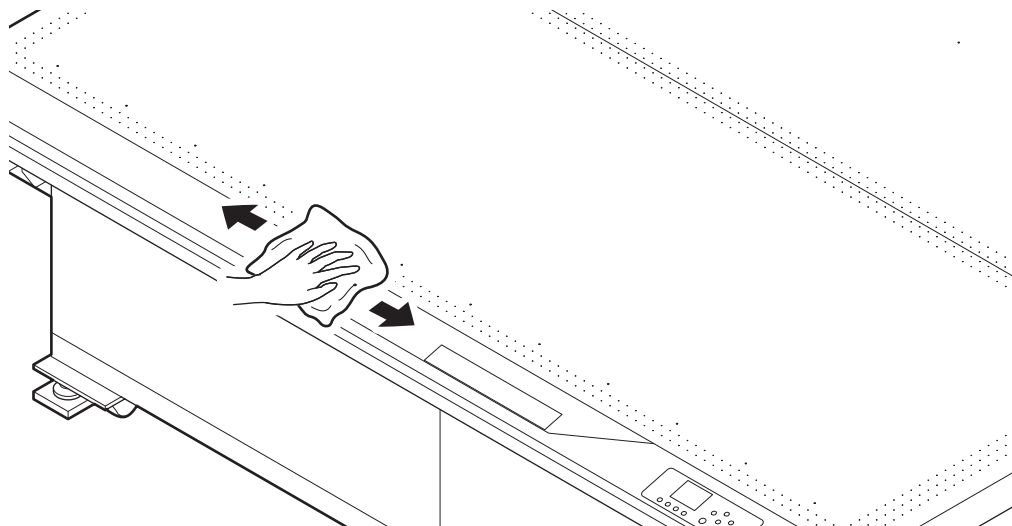

Cutter Blade Maintenance

Cutting works that have adhesive on them will cause the adhesive to stick to the blade, reducing sharpness. Wipe with alcohol or similar.



- Avoid touching the cutter blade during maintenance. This may cause injury.

Units

- Important!**
- Before mounting and after removal, wipe the rear surface of the unit and the mounting surface of the Y-slider.

Standard unit, tangential unit (TUT)

If cutting dust or debris adheres to the surface, wipe with a dry cloth or the like.

- Important!**
- Do this work with the power off.
 - Remove any mounted tools.

Reciprocating tool

If cutting dust or debris adheres to the surface, blow it away with a blower or wipe with a dry cloth or the like.

- Important!**
- Do this work with the power off.
 - Remove any mounted tools.

1

Clean the sensor and guide rail.



- Do not use organic solvents, which will dissolve the lens surface.
- Do not touch the sensor directly with your fingers. This may reduce sensor sensitivity.

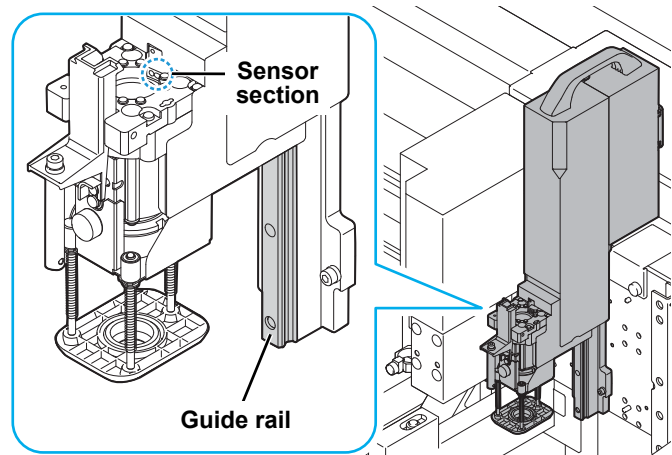

Electric reciprocating tool (E12, E35, E60)

Grease the sliding surface of the reciprocating main shaft periodically (approximately once a month).
Grease used: SPA-0163 grease tube (provided with main unit)

1 Remove reciprocating unit cover.

Important!

- Do this work with the power off.

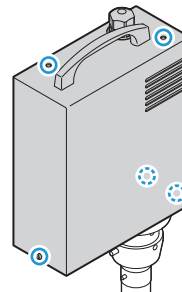

2 Using a cotton swab, grease the area between the plates of the reciprocating main shaft (sliding surface with bearing).

Important!

- Amount of grease to apply: approx. 0.05 g.

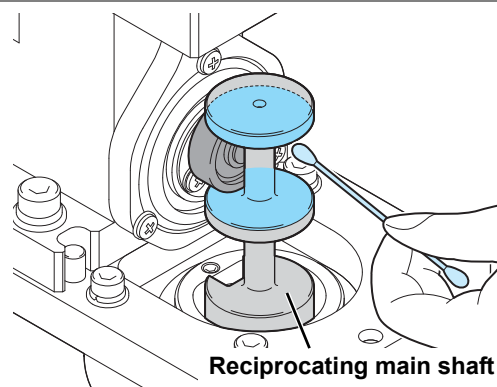

3 Reattach the reciprocating unit cover.

Cleaning the Vacuum Filter

Work suction will be weaker if the filter of the optional vacuum becomes clogged. Clean the filter regularly.

1 Remove the vacuum filter lid.

- Unhook and remove the lid.

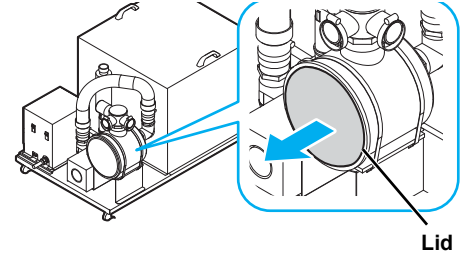

2 Remove the filter.

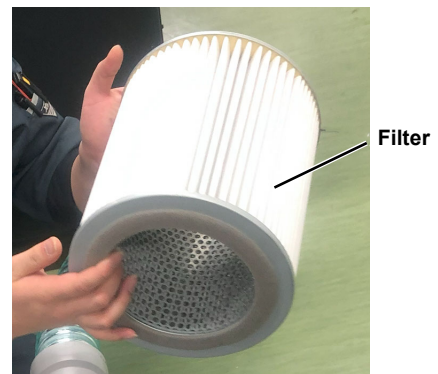

3 Vacuum the filter to remove dust or debris.

4 Reinstall the filter in the original position.

- (1) Hold the filter as you fully close the lid.
 - The lid cannot be hooked unless it is fully closed.
- (2) Hook the lid.

5 Reattach the lid removed in step 1.

6 Vacuum the silencer guard at the rear to remove dust or debris.

- Clean the mesh on the surface of the guard.

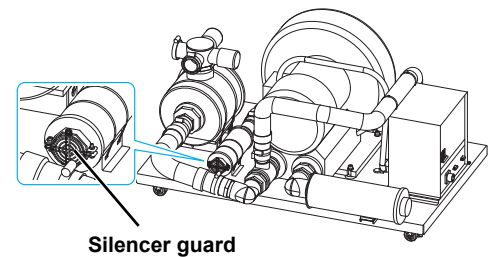

Cleaning the Camera Unit

It is essential to clean the camera unit after use, because dust and fingerprints tend to remain on it over the course of use.

The lens in particular requires appropriate maintenance.

1

Remove debris or cutting dust from the lens surface with a vacuum or air duster.

2

Using a dedicated cleaning cloth lightly moistened with anhydrous alcohol, wipe the lens in a swirling motion from the center outward.

Important!

- Do this work with the power off.
- To prevent undue wear, do not apply force when wiping the lens.

Cleaning the Photoelectric Sensors and LED Pointer

If cutting dust or debris adheres to the photoelectric sensors or LED pointer, wipe with a dry cloth or the like.

Important!

- Photoelectric sensors are located at both ends of the Y-bar.

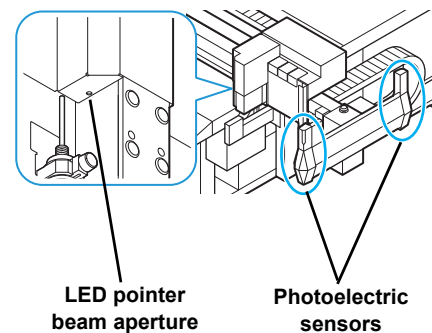

Cleaning the Mark Sensor/Y-Bar Rail

If cutting dust or debris adheres to the mark sensor, wipe with a dry cloth or the like.

Additionally, if the Y-bar rail becomes dirty, operation may become noisy or other problems may occur. Wipe off any dust with a dry cloth.

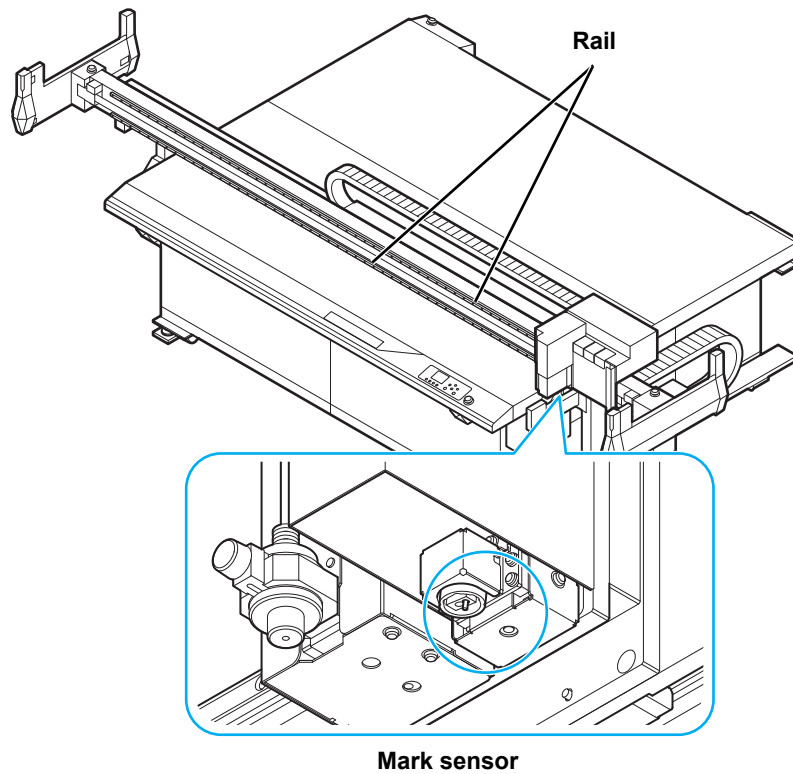

Dust-Collector Hose Maintenance (Only R10)

Suction for collecting cutting dust will be weaker if the dust-collector hose becomes clogged. Visually check the entire hose. Use “R10 Dust Collector Box Check” in the Machine Setup menu (P.6-26 available from firmware version 1.8.0) to regularly confirm that there is sufficient suction from the dust collector box opening.

Clean the hose if it is clogged.

Also regularly remove any accumulated cutting dust from inside the dust collector in accordance with the dust collector operating manual to ensure that suction power is not reduced.

1 Disconnect the dust-collector hose joints and clean the hose.

- The dust-collector hose joints are located at the positions shown in the following figure.

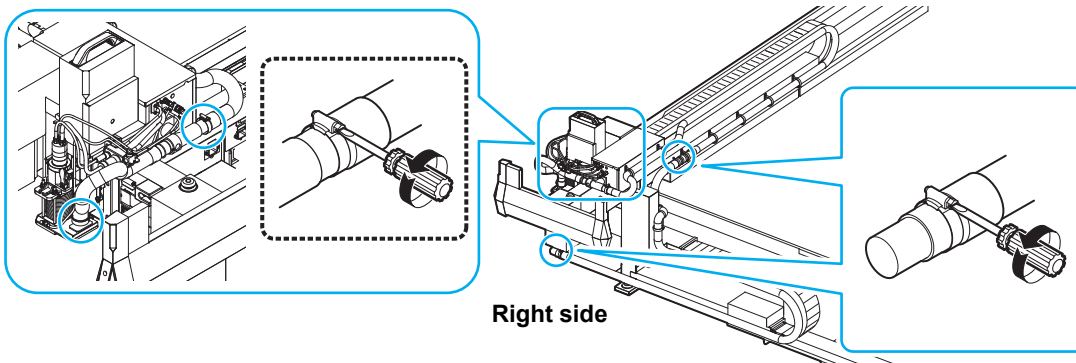

2 Check to confirm cutting dust has not clogged inside the dust collector box.

Important!

- When checking or cleaning inside the dust collector box, first, confirm no tool is mounted on the spindle or the spindle is not attached. Failure to observe these instructions may result in injury.

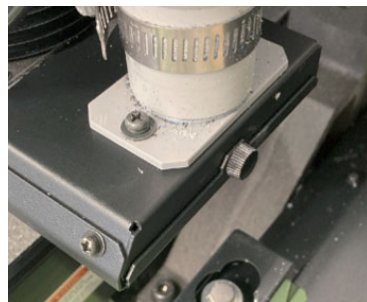
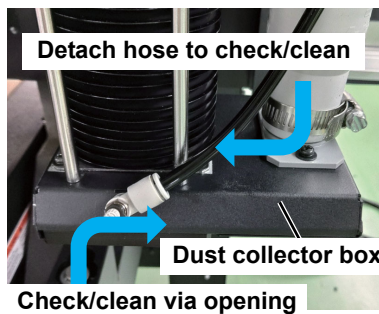

With an R10 fitted with a knob screw, removing the screw makes it easier to check and clean inside the dust collector box.

3 Reconnect the hose joints in the original positions.

Cleaning with Auxiliary Air (Only R10)

Use auxiliary air to blow away cutting dust or debris adhering to the operating panels or other parts.

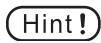

- A cleaning hose must be connected in order to use the auxiliary air.
- The cleaning hose can be connected to the quick connector on the blue knob at the right of the head.



- The auxiliary airflow may cause the hose to fly around if you accidentally let go of it. Turn off the airflow before releasing or disconnecting the hose. (The tip of the hose may be dangerous if it enters your eye.)
- Before connecting the cleaning hose to the quick connector, make sure that air is coming out of the blue knob at the right of the head.

1

Connect the cleaning hose.

- Connect the cleaning hose to the quick connector and to the blue dial at the right of the head.

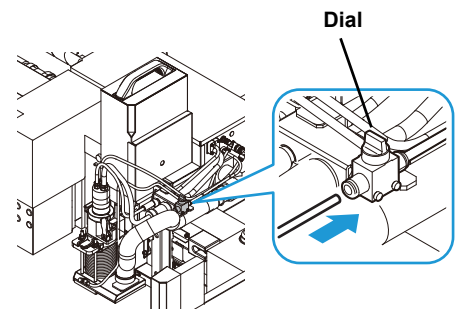

2

Clean the machine as needed.

- Adjust the auxiliary airflow with the dial at the right of the head.

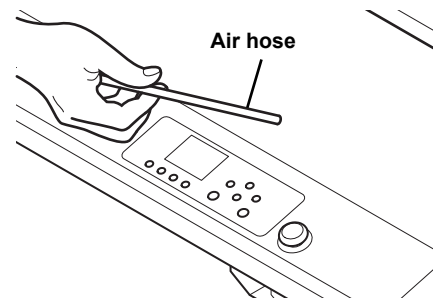
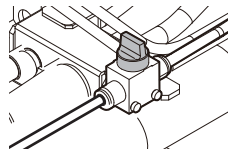

- Be sure to detach the cleaning hose after cleaning. If it is left attached, it may become trapped in moving parts and be damaged.

Cleaning the Router Blade (End Mill) (Only R10)

Using auxiliary air or a brush to clean debris or cutting dust on the router blade (end mill).



- Do not use a compressed air gun to clean the spindle (inside the collet chuck). This may blow dust inside the spindle, leading to failure.

Chapter 8

Troubleshooting



About this chapter

This chapter explains the procedures for troubleshooting and addressing messages on the display.

Troubleshooting Scenarios	8-4	Status Messages	8-13
Troubleshooting	8-3	Mark Origin Detection Errors	8-14
Does not work when power is turned on	8-3	Error numbers displayed on spindle controller	8-15
Sending data from software does not work ..	8-3	Sample Cutting.....	8-16
An error occurs when data is sent	8-3	Cutting Samples to Troubleshoot Issues ...	8-17
The tool lifts up works (only standard unit) ..	8-4	Sample Cutting.....	8-15
Drawn lines are broken or faint	8-4	Cutting Samples to Troubleshoot Issues ...	8-16
No reciprocating movement (only TUT)	8-4		
Warning/Error Messages	8-5		
Resolvable Errors	8-5		
System Halt and Other Errors	8-13		

Troubleshooting Scenarios

Issue	Corrective action
<p>Inadequate cutting</p> <ul style="list-style-type: none"> • Works may not be cut completely even if blade protrusion when the cutter is down exceeds work thickness. 	<p>Stronger pressure when the cutter is down can ensure that works are cut.</p> <ul style="list-style-type: none"> • Enter a Z offset (for FBT). (👉 P.4-36) 👉 P.3-17 “Configuring Tool Settings”
<p>The reciprocating cutter leaves works uncut at beginning and end points.</p> <ul style="list-style-type: none"> • Cutting may be incomplete at positions where the cutter is lowered or raised. 	<p>Increase the start offset setting to move forward the position where the cutter is lowered.</p> <p>👉 P.3-17 “Configuring Tool Settings”</p>
	<p>Increase the end offset setting to move backward the position where the cutter is raised.</p> <p>👉 P.3-17 “Configuring Tool Settings”</p>
<p>The swivel cutter leaves works uncut at beginning and end points.</p>	<p>Set up overcutting.</p> <p>👉 P.4-37 “Eliminating Pieces Left Uncut in Works (Standard Unit)”</p>
<p>Circle start and end points do not match.</p> <ul style="list-style-type: none"> • Circle start and end points to cut may be misaligned due to work thickness and hardness. 	<p>Set up circular theta correction to compensate for the amount of misalignment.</p> <p>👉 P.3-36 “Circle Θ Correction”</p>
<p>The vacuum or dust collector is not sucking.</p>	<p>Clean the filter and hose.</p> <p>👉 P.7-5 “Cleaning the Vacuum Filter”,</p> <p>👉 P.7-8 “Dust-Collector Hose Maintenance (Only R10)”</p>

Troubleshooting

Double-check the following points if you suspect mechanical failure. If the measures do not restore normal operation, contact a dealer or our service office.

Does not work when power is turned on

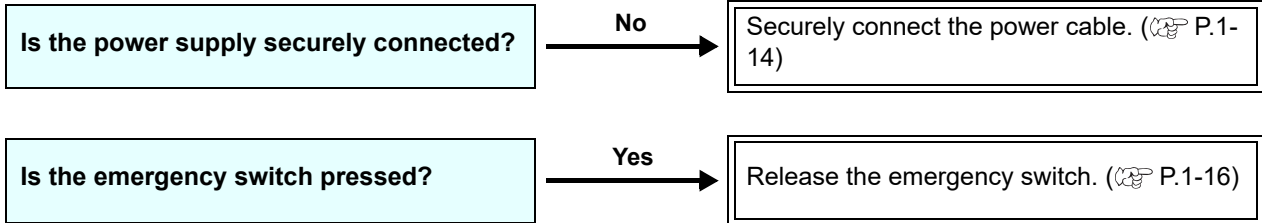

Sending data from software does not work

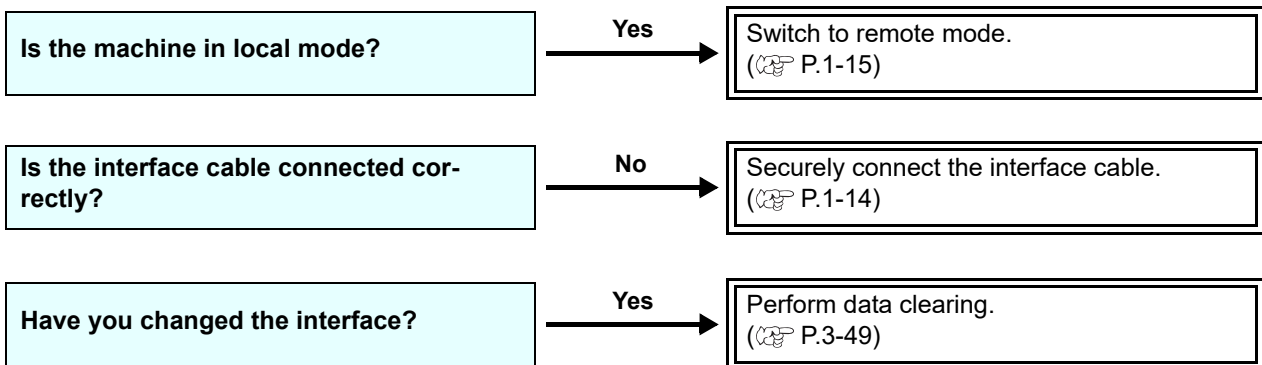

An error occurs when data is sent

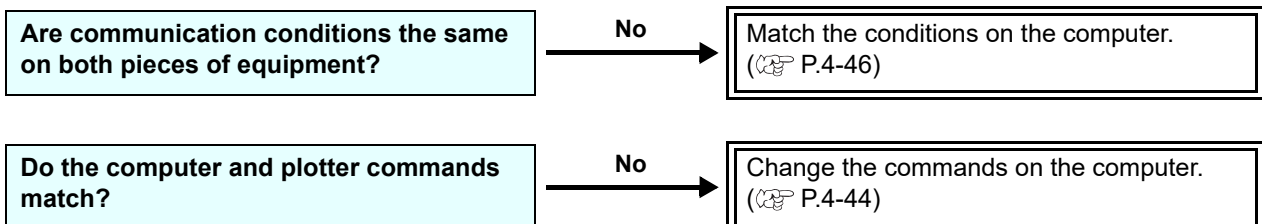

The tool lifts up works (only standard unit)

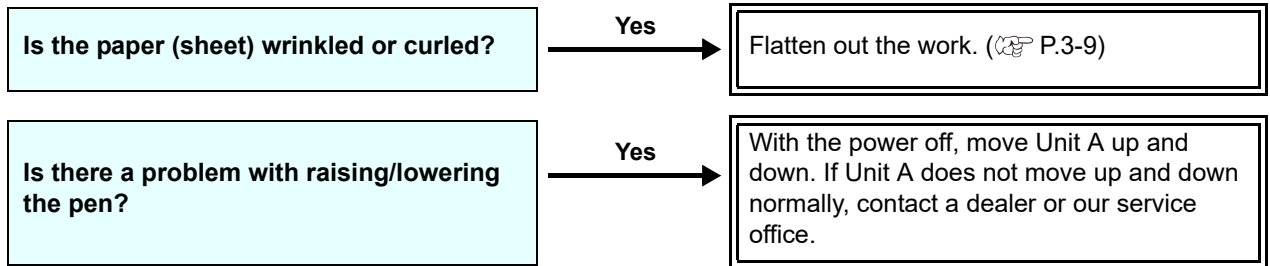

Drawn lines are broken or faint

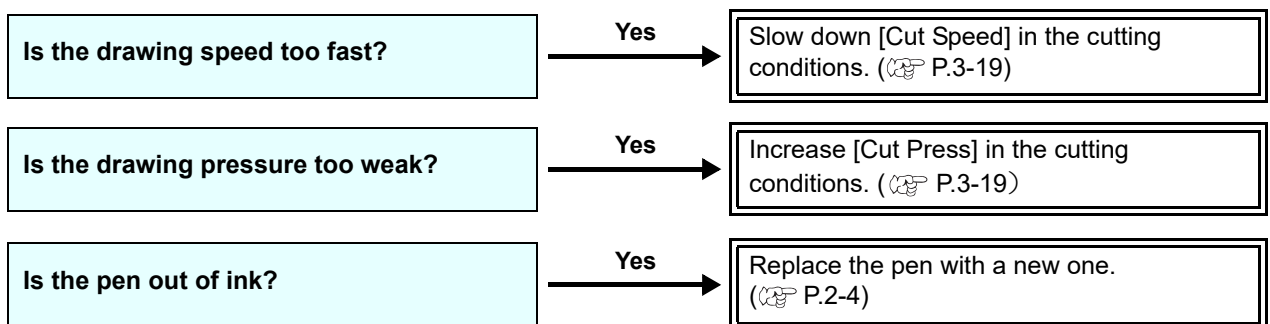

No reciprocating movement (only TUT)

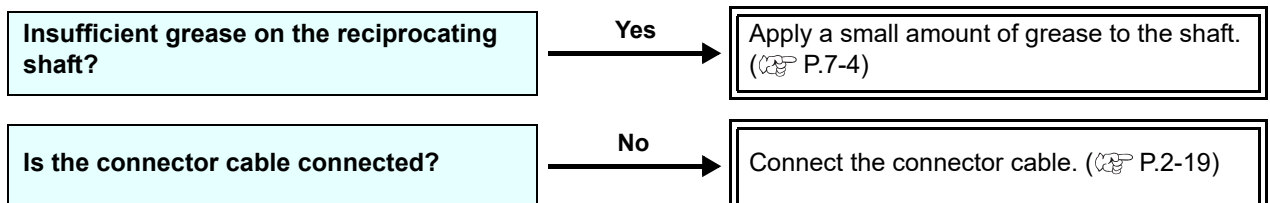

Warning/Error Messages

In case of problems with the machine, a message appears on the display. Take appropriate measures based on the message.

Resolvable Errors

Message	Cause	Corrective action
INFORMATION 129 Battery Exchange	The internal clock battery is spent and must be replaced.	Contact a dealer or our service office.
ATTENTION 203 Maintenance command	Communication error occurred.	Turn off the power on the machine and turn it on after a while. If this error continues to be displayed, contact your local dealer or our service office.
ERROR 401 Motor X	The Y-bar motor was overloaded.	
ERROR 402 Motor Y	An overcurrent error was detected in the head motor.	
ERROR 403 X Current	An overcurrent was detected in the Y-bar motor.	
ERROR 404 Y Current	An overcurrent was detected in the head motor.	
ERROR 499 Motor ZA	The Z motor was overloaded.	
ERROR 499 Motor ZB		
ERROR 499 Motor ZC		
ERROR 499 Motor ZD		
ERROR 49a ZA Current	An overcurrent error was detected in the Z motor.	
ERROR 49a ZB Current		
ERROR 49a ZC Current		
ERROR 49a ZD Current		
ERROR 49b Motor TB	The T motor was overloaded.	
ERROR 49b Motor TC		
ERROR 49b Motor TD		
ERROR 49c TB Current	An overcurrent error was detected in the T motor.	
ERROR 49c TC Current		
ERROR 49c TD Current		
ERROR 49d Motor Brush Z	The motor moving the R10 unit brush up and down was overloaded.	
ERROR 49e Brush Z Current	An overcurrent error was detected in the motor moving the R10 unit brush up and down.	

Message	Cause	Corrective action
ERROR 4a0 X1 Servo AMP LinkUP Err	A X motor control unit problem occurred.	Turn off the power on the machine and turn it on after a while. If this error continues to be displayed, contact your local dealer or our service office.
ERROR 4a0 X2 Servo AMP LinkUP Err		
ERROR 4a1 Y Servo AMP LinkUP Err	A Y motor control unit problem occurred.	
ERROR 4a2 Origin search fail	Origin sensor could not be detected.	Turn off the power on the machine and turn it on after a while. If this error continues to be displayed, contact your local dealer or our service office.
ATTENTION 4a3 AC AMP[00] RS232 ERR	Unable to communicate with motor control unit.	
ATTENTION 4a4 Front Vacuum Error	An error was detected in the vacuum 1.	Turn off the plotter and vacuum. Wait a while and turn them back on.
ATTENTION 4a4 Rear Vacuum Error	An error was detected in the vacuum 2.	
ERROR 4b1 Reciprocating motor B: Exx	A problem was detected with the motor (reciprocating motor) moving the B-unit blade up and down.	<ul style="list-style-type: none"> Reduce the media cutting speed. (☞ P.3-19) If this occurs repeatedly, the reciprocating unit is damaged. Contact a dealer or our service office.
ERROR 4b1 Reciprocating motor C: Exx	A problem was detected with the motor (reciprocating motor) moving the C-unit blade up and down.	
ERROR 4b2 Motor Router Z	The motor moving the R10 unit router up and down was overloaded.	Turn off the power on the machine and turn it on after a while. If this error continues to be displayed, contact your local dealer or our service office.
ERROR 4b3 Router Z Current	An overcurrent error was detected in the motor moving the R10 unit router up and down.	
ERROR 50a Y Origin	A problem was detected with Y origin detection.	
ERROR 556 Y Limit Sensor	The head has exceeded the operating range in the Y direction.	
ATTENTION 557 Obstacle detection	The light curtain was triggered.	Remove the obstacle from the light curtain detection area.
ERROR 560 X Limit Sensor	The head has exceeded the operating range in the X direction.	Turn off the power on the machine and turn it on after a while. If this error continues to be displayed, contact your local dealer or our service office.
ERROR 562 X1 Origin	A problem was detected with X origin detection.	
ERROR 562 X2 Origin		
ERROR 563 ZA Origin	A problem was detected with Z (A station) origin detection.	
ERROR 563 ZB Origin	A problem was detected with Z (B station) origin detection.	
ERROR 563 ZC Origin	A problem was detected with Z (C station) origin detection.	
ERROR 563 ZD Origin	A problem was detected with Z (D station) origin detection.	
ERROR 564 TB Origin	A problem was detected with Θ (B station) origin detection.	
ERROR 564 TC Origin	A problem was detected with Θ (C station) origin detection.	

Message	Cause	Corrective action
ERROR 564 TD Origin	A problem was detected with Θ (D station) origin detection.	
ATTENTION 567 ZS Sensor	Edge detection sensor did not respond.	Make sure that the pen is attached to the pen holder. If this error is displayed while the pen is properly installed, turn off the power on the machine and turn it on after a while. If this error continues to be displayed, contact your local dealer or our service office.
ATTENTION 568 Camera Not Connected	Could not connect to camera.	A command has been executed with conditions that can only be detected by the camera. Change the mark detection setting to "Camera", then enable the camera.
	Camera is not selected.	The mark detection setting is set to "Sensor". Change it to "Camera".
ATTENTION 569 Camera Communication	Cannot connect to camera app (OBSCURAS).	Check to confirm that the camera app (OBSCURAS) is running and communication is normal. If not connected, establish a connection to the camera app (OBSCURAS). * Marks that can be detected by the sensor will automatically be detected by the sensor.
	Camera communication is not available.	Check the LAN cable connection. If there are no problems, try restarting the camera app (OBSCURAS) and restarting the plotter.
ATTENTION 56a Camera Process	Camera communication is not available.	Turn off the main power to both the connected PC and the machine, and then turn it on again after a while.
ERROR 572 Not Found X1 Org	An error was detected in the origin sensor.	Turn off the power on the machine and turn it on after a while. If this error continues to be displayed, contact your local dealer or our service office.
ERROR 572 Not Found X2 Org		
ERROR 573 Not Found Y Org		
ERROR 574 Not Found ZA Org		
ERROR 574 Not Found ZB Org		
ERROR 574 Not Found ZC Org		
ERROR 574 Not Found ZD Org		
ERROR 575 Not Found TB Org		
ERROR 575 Not Found TC Org		
ERROR 575 Not Found TD Org		

Message	Cause	Corrective action
INFORMATION 901 Invalid Operation	The function is not available.	This is an operation that cannot be performed. Please refer to the corresponding page of the operation manual.
ATTENTION 92c MDL Emergency	An emergency stop instruction was received from the MDL command interface.	Perform the emergency stop release operation on the external device that instructed the emergency stop.
INFORMATION c10 Commands	Received a code other than a COMMAND code.	Check the command setting on the host computer.
INFORMATION c11 Parameter	A parameter outside the numerical range has been received.	
ATTENTION c17 Mode Settings	Positioning was specified for the unit set to pressure control, or vice versa.	Change the application software settings to match the settings on the device side.
ATTENTION c18 Parameter Range	The value range of the command parameter specified by the application software is not appropriate.	Check the command settings of the application software.
ATTENTION c19 Many Parameters	Too many command parameters specified by the application software.	
INFORMATION c20 I/O	The communication condition is different.	Make the communication condition same as that of the host computer side. (☞ P.4-46)
INFORMATION c31 No Data	“COPY” was executed, but no data is saved to the receive buffer.	Please refer to the copy function. (☞ P.4-13)
INFORMATION c32 DataTooBig	The received data is too big for multiple sheet cutting.	
INFORMATION c36 Mark Detect	No register mark was detected. Or a register mark could not be detected five times in succession for a multi mode copy (could not continue using auto skip).	<ul style="list-style-type: none"> • Make sure work is not floating. • Check to see if the starting point to detect the register mark has been set properly. (☞ P.5-15) • Check to see if the black register mark is printed against the white background. • Check to see if there is no dust or dirt between the register marks. • Check to see if there is no mistake in register mark settings. (☞ P.5-10) • Check the camera lens for dirt. • Adjust the camera. • Confirm the status and the settings described above. If still no register mark is detected, contact your distributor or a sales office of Mimaki.
INFORMATION c37 Mark Org	The origin point was detected outside the cutting area.	Arrange the register marks inside the sheet.

Message	Cause	Corrective action
INFORMATION c38 Mark Scale	Register mark detection was achieved. However, this error is attributable to a false detection or a compensation value setting error, since the calculated compensation value is wrong.	Correct the compensation value if it is wrong, and perform detection again.
	The required scale compensation value was not smaller than 1.3 times or not greater than 0.7 times.	Remove the cause of the detection error, for example, correct the blurred print of register mark data and then retry.
	A detection error occurred since the distance from the adjacent graphics was too short.	Increase the distance from the adjacent graphics properly, and perform printing again.
	The designated spacing between the register marks is not correct.	The value of the spacing between the register marks designated by the command is wrong and it is attributable to a selection error of data. Therefore, check the output data.
	The print is not uniform and some graphics are omitted.	Correct the graphic data to obtain a uniform print and perform printing again.
	As the printed register mark was blurred, it was not read correctly and the register mark of the next graphics was read by mistake.	Perform printing again, taking care that the print is not blurred.
INFORMATION c39 Mark ID	Failed to detect the base register mark.	See "INFORMATION c36" corrective actions. (☞ P.8-8)
	ID code could not be read properly.	<ul style="list-style-type: none"> • Check that the data ID code is printed correctly. • Perform printing again, taking care that the print is not blurred.
ATTENTION c1a Missing Parameters	Too few command parameters specified by the application software.	<ul style="list-style-type: none"> • Check the command settings of the application software.
ATTENTION c1c Option Required	There are no options required to execute the command.	<ul style="list-style-type: none"> • Add optional features.
ATTENTION c1d Device Select	Sensors and other devices are not available.	<ul style="list-style-type: none"> • Check to confirm that the sensor and camera sensors are enabled and correctly selected. (☞ P.5-10)
ATTENTION c3a Mark Not Detected	As the printed registration mark was blurred, it was not read correctly and the registration mark of the next graphics was read by mistake.	<ul style="list-style-type: none"> • Check the settings and operation procedures in accordance with the software instruction manual.
INFORMATION c3d Pen Stroke	Pen height is not appropriate.	Check the pen holder installation.
ATTENTION c3f Pen Head	Pen head initialization failed.	Turn off the power on the machine and turn it on after a while. If this error continues to be displayed, contact your local dealer or our service office.
INFORMATION c60 PenEncoder	The height of the pen cannot be detected.	
ATTENTION c68 A tool has come off	A tool has detached from the holder. Or it was intentionally removed.	Check to confirm that the tool is correctly mounted.

Message	Cause	Corrective action
INFORMATION c6d Offscale	The cutting data exceeds the effective cutting area.	Either increase the size of the cut area or reduce the data.
	For R10 If you attempt to cut deeper than the cutter length of the end mill, an "Offscale" error will occur, limiting the cutting depth.	To cut more deeply into thick workpieces, replace the tool with an end mill with a longer cutter length.
ERROR ca5 Spindle	An overcurrent error was detected in the Spindle motor.	Turn off the power on the machine and turn it on after a while. If this error continues to be displayed, contact your local dealer or our service office.
ERROR ca6 Unit mounting position	The unit is installed in the wrong position.	Install the unit correctly. (☞ P.2-2)
ERROR ca7 Tool mounting position	Unavailable tools detected.	<ul style="list-style-type: none"> • Install the tool correctly. • If the barcode sticker is dirty, replace it.
ATTENTION ca8 Edge Detect: B-Unit	Failed to detect the cutting edge of B-Unit.	<p>Make sure you have installed the tool correctly.</p> <p>If automatic cutting edge detection is not possible, perform detection manually. (☞ P.3-14)</p>
ATTENTION ca9 Edge Detect: C-Unit	Failed to detect the cutting edge of C-Unit.	
ATTENTION caa Edge Detect:D-Unit	Failed to detect the cutting edge of D-Unit.	
ATTENTION cab Work thickness over	The work thickness measurement result exceeds the upper limit for cutting.	Change the work to one with a thickness that can be cut. If the work thickness is automatically measured without attaching the pen cap, attach it, restart the device, and measure again.
ATTENTION cac Unrecognizable Mark	Marks were not recognized.	<ul style="list-style-type: none"> • Check to see if the starting point to detect the register mark has been set properly. (☞ P.5-15) • Verify that the shape of the printed register mark is the same as the one specified in the operation or application. • Make sure that the size of the printed register mark is approximately 10 mm on each side.
ATTENTION cad Mark Detection Failed	Failed to detect the mark.	<ul style="list-style-type: none"> • Check to see if the starting point to detect the register mark has been set properly. (☞ P.5-15) • Set the work so that it has the minimum tilt possible. • Check for another mark or print data near the mark to be detected.
ATTENTION caf No Specified Tool	An attempt was made to perform a function without the required tools installed.	<ul style="list-style-type: none"> • Check to confirm that the required tool is correctly mounted at the specified position. (☞ P.4-55 "Checking Machine Information" > [Unit & Tool]) • If the cut is caused by data from the host computer, check the settings of the application software.

Message	Cause	Corrective action
ATTENTION cb1 Pressure level TUT	The pressure level setting ranges differ for the low-pressure TUT and high-pressure TUT. Pressure levels were specified by a command outside the respective setting ranges.	<ul style="list-style-type: none"> Specify the pressure level within the setting range of each of the low pressure TUT and high pressure TUT.
INFORMATION cb3 Time to recommend exchange	The recommended replacement time for the drive system components indicated on the panel is nearing.	Contact a dealer or our service office.
INFORMATION cb4 Time to recommend exchange	The recommended replacement time for the drive train components indicated on the panel has passed.	Contact a dealer or our service office.
INFORMATION cb8 Edge Detect not Comp.	Operation cannot be executed because blade edge detection has not been completed.	Clear the data (☞ P.3-49) before completing blade edge detection (☞ P.3-14).
ATTENTION cb9 Tool Length:B-Unit	The length of the tool (blade) attached to the unit shown on the panel has changed since the last edge detection.	Clear the data (☞ P.3-49) and then execute the blade edge detection (☞ P.3-14) again.
ATTENTION cba Tool Length:C-Unit		
ATTENTION cbb Tool Length:D-Unit		
ATTENTION cbc Measurements are abnormal	As a result of flatness measurement, the difference between the maximum and minimum values exceeds the normal value. It is expected that there will be debris, cutouts, deep indentations, etc. on the mat surface.	<ul style="list-style-type: none"> Check the mat surface for any abnormalities such as dust, cutouts, deep dents, etc. If there is no abnormality on the mat surface, please contact your dealer, our sales office or call center.
ATTENTION cbd Spindle Controller	Stopped due to overload during cutting. Refer to "Error numbers displayed on spindle controller" (☞ P.8-15)	<ul style="list-style-type: none"> Restart the machine. Change the cutting conditions before cutting again. <ul style="list-style-type: none"> Increase the rotation speed. Reduce the cutting depth for each cut.
ATTENTION cbe Felt mat Upper limit	The thickness of the felt mat calculated from the measurements in flatness measurement exceeds the maximum thickness that can be used.	<ul style="list-style-type: none"> If the felt mat is a non-genuine product, replace it with a genuine product. If there are any labels or debris on the felt mat surface, remove them, clean, and then repeat flatness measurement.
ATTENTION cbf Felt mat Lower limit	The thickness of the felt mat calculated from the measurements in flatness measurement is below the minimum thickness that can be used.	<ul style="list-style-type: none"> Replace the felt mat with a new one. If flatness measurement was performed without attaching the pen cap, attach the pen cap, then measure again.
ATTENTION cc0 Underlay upper limit	The underlay thickness measurement result exceeds the maximum allowed thickness.	<ul style="list-style-type: none"> Replace the underlay with thinner underlay. If the underlay thickness was measured automatically without attaching the pen cap, attach the pen cap, then measure again.

Message	Cause	Corrective action
ATTENTION CC1 Short for cut area	The cutting range check before cutting revealed that the work is smaller than the cutting range.	<ul style="list-style-type: none"> Replace the work, reposition it, or change the drawing origin to allow cutting to start. Once the issue has been cleared, either resend the data or copy it.
ATTENTION cc2 Unit and tool combination	The unit (TUT) and the attached tool combination was not permitted, so the tool cannot be used.	<ul style="list-style-type: none"> After the warning is displayed, a screen is displayed which unit is causing the problem. Remove the mounted tool or replace the tool with the unit where the available tool (TUT) is located.
ATTENTION CC4 Cancelled	The operator canceled the assignment during the mark teaching process.	<ul style="list-style-type: none"> No specific action is required as it just indicates a cancellation performed by the user. Perform the operation again if needed.
ATTENTION CC5 Out of range	The assigned position for the mark teaching was out of the cut area.	<ul style="list-style-type: none"> Reset the cut origin to the right and front with respect to the printed objects, then resend the data.
ATTENTION cc6 Z-down Pos limit	Attempted to crease at a depth greater than the depth to which the creasing tool can be pressed.	<ul style="list-style-type: none"> A warning guidance for the Z-down position is displayed. Select either Data Clear or resume processing based on the guidance. If Data Clear is selected to change cutting conditions, check the following: <ol style="list-style-type: none"> (1) The work thickness setting is set properly. (2) For position control: Set the specified Z-position in the cut data to a lower depth. (3) For pressure control: Lower the pressure level value.
ATTENTION cc7 Origin mark not detected	After turning on the power, the Type.5 register mark detection command was executed without performing mark origin detection first.	<ul style="list-style-type: none"> If the work has not been rotated (0°), continue in REMOTE mode. If it has been rotated (90°, 180°, or 270°), first clear the data. Then, perform mark origin detection and redo the data output.

System Halt and Other Errors

Important!

- If other system halt numbers or error numbers are displayed, turn off the power on the machine and turn it on after a while.
If this error continues to be displayed, contact your local dealer or our service office.

Status Messages

These messages do not indicate errors but require an appropriate response.

Message	Cause	Corrective action
!Data Remain	An attempt was made to perform an operation that cannot be performed while paused.	Please change remote mode and draw (cut) all data. Or, execute Data Clear to abort the plotting.
Change the work Press Enter_key.	The plotter is waiting for the work to be replaced during continuous copying in the single mode.	Replace the work with a new one, and resume continuous copying.
Safe sensor reacts. Please remove obstacle.	The light curtain was triggered.	Remove the obstacle from the light curtain detection area.
Release the Emergency switch	The Emergency switch is pushed.	Release the emergency switch.
Failed to detect ZS sensor response. Please make sure the tool is attached to A-Unit.	Edge detection sensor did not respond.	Make sure that the pen is attached to the pen holder. If this error is displayed while the pen is properly installed, turn off the power on the machine and turn it on after a while. If this error continues to be displayed, contact your local dealer or our service office.
Thickness is not set.	Work thickness is not set.	Set the work thickness. (☞ P.3-9)
Cutting edge no detect.	Some tools do not perform cutting edge detection.	Perform the cutting edge detection for all installed B to D-Unit tools. (☞ P.3-14)

Mark Origin Detection Errors

Error No.	Cause	Corrective action
1	The machine attempted to retrieve data captured by the camera application, but there was no data.	(1) Restart the camera application. (2) Restart the machine. (3) If the issue persists, contact your dealer or our sales office or call center.
3	The camera could not be recognized.	(1) Restart the camera application. (2) Restart the machine. (3) Check the LAN connection. (4) If the issue persists, contact your dealer or our sales office or call center.
4	Camera connection could not be confirmed.	
5	Dust or dirt has been detected on the lens.	(1) Make sure the lens is not dirty and clean as needed.
6	Image composition not possible because image capture failed during ID data detection.	(1) If the issue does not recur after detection is attempted again, there is no problem. (2) Restart the camera application. (3) Restart the machine.
11	The mark or work edge you attempted to capture could not be recognized.	(1) Check the mark or work edge detection position. (2) Check the mark shape. (3) Make sure the printed mark matches specifications ( P.5-2).
12	Marks were too close to each other, causing multiple marks to be detected within the capture area.	(1) Leave more space between marks and print them again.
13	Marks were detected, but the angle of rotation was not recognized.	(1) If the issue does not recur after detection is attempted again, there is no problem. (2) Restart the camera application.
14	The detection position is too far forward, so the mark is out of the capture area.	(1) Move the pointer to the mark origin position and retry detection.
15	The detection position is too far back, so the mark is out of the capture area.	
16	The detection position is too far left, so the mark is out of the capture area.	
17	The detection position is too far right, so the mark is out of the capture area.	
90	An error occurred on the main unit during capture that prevented the camera from shooting.	(1) If the issue does not recur after detection is attempted again, there is no problem. (2) Restart the camera application. (3) Restart the machine.
91	Not connected to the camera application.	(1) Restart the camera application. (2) Restart the machine. (3) Check the LAN connection.
92	The data captured by the camera application does not match the data you were attempting to obtain.	(1) Restart the camera application. (2) Restart the machine. (3) If the issue persists, contact your dealer or our sales office or call center.
93	Image capture by the camera failed due to a communication error between the camera application and the camera, or a similar problem.	(1) Restart the camera application. (2) Restart the machine. (3) Check the LAN connection.

Error numbers displayed on spindle controller

Error No.	Cause	Corrective action	
Warning Displays	A0	The spindle motor cable is not connected. Or the connector contacts are faulty.	<ul style="list-style-type: none"> • Check the motor cable.
	A1	The compressed air pressure dropped during rotation.	<ul style="list-style-type: none"> • Check the compressed air pressure. • Check whether the compressor is operating.
	A2	The temperature inside the unit has risen.	<ul style="list-style-type: none"> • Turn off the plotter power supply, and wait a while before turning back on.
	A3	The spindle motor is overloaded.	<ul style="list-style-type: none"> • Alter the cutting conditions.
	A4	An emergency stop signal was input while the motor was stopped.	
	A5	The compressed air pressure is too high.	<ul style="list-style-type: none"> • Check the compressed air pressure.
Error Displays	E1	The current exceeded the tolerances.	<ul style="list-style-type: none"> • Alter the cutting conditions. • Turn off the plotter power supply, and wait a while before turning back on.
	E2	The voltage exceeded the tolerances.	<ul style="list-style-type: none"> • Turn off the plotter power supply, and wait a while before turning back on.
	E3	The motor cable connector is detached. Or the sensor is faulty.	<ul style="list-style-type: none"> • Check the motor cable connector.
	E4	The temperature inside the unit increased abnormally.	<ul style="list-style-type: none"> • Turn off the plotter power supply, and wait a while before turning back on.
	E5	Circuit abnormality.	
	E6	The motor is restrained and has stopped rotating for more than 3 seconds.	<ul style="list-style-type: none"> • Turn off the plotter power supply, remove the cause of the problem, and wait a while before turning back on.
	E7	<ul style="list-style-type: none"> • The compressed air pressure was too low when the motor started. • The compressed air pressure was too low continuously for at least 4 seconds while the motor was operating. 	<ul style="list-style-type: none"> • Check the compressed air pressure. • Turn off the plotter power supply, and wait a while before turning back on.
	E8	The overload continued for a specified length of time or longer.	<ul style="list-style-type: none"> • Turn off the plotter power supply, and wait a while before turning back on.
	EA	A rotation command was input before the power was turned on.	<ul style="list-style-type: none"> • Turn off the plotter power supply, and wait a while before turning back on.
	EL	An unsupported spindle motor was connected.	<ul style="list-style-type: none"> • Use a dedicated CFX spindle motor.
	EH	The motor speed exceeded the preset value for a specified length of time.	
	EE	<ul style="list-style-type: none"> • The motor was started while an emergency stop signal was input. • An emergency stop occurred while rotating. 	<ul style="list-style-type: none"> • Turn off the plotter power supply, and wait a while before turning back on.
	EC	Internal memory abnormality.	
Et	The temperature inside the motor increased abnormally.		



(Extract from Nakanishi Inc. operation manual)

Sample Cutting

The machine can cut a sample stored internally to enable troubleshooting if data cannot be cut correctly. The offset amounts for the work used can also be checked and updated in the FineCut/Coat9 and CAMLINK2 settings.

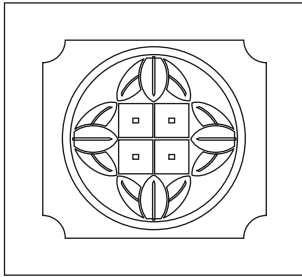
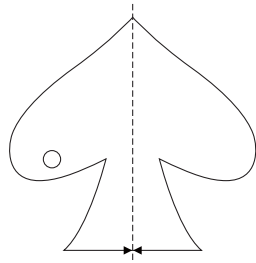
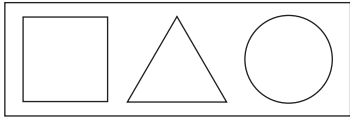

- Sample cutting is not available unless the receive buffer is empty, in which case an error is displayed. Perform data clearing in advance.

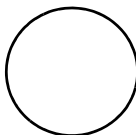
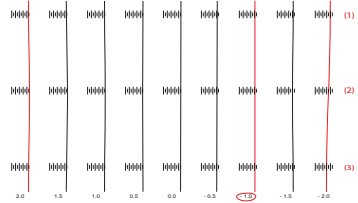
Sample Patterns and Overview	
<p>Crest Used with the tool selected in [Tool Select]. This sample is a crest with a variety of line styles.</p> 	<p>Spade Performs both up-cuts and down-cuts in a single pattern. Select the cutting method that produces the cleanest cuts.</p> 
<p>Square, triangle, and circle Cuts the inner lines before the outer one.</p> 	<p>V-CUT Used for basic quality checking with the V-cut tool.</p>  <p>Required tools Units B to D: V-cut tool</p> <ul style="list-style-type: none"> • Available only when V45 and VAS are selected.
<p>R = 3/5/10/15/20/50/100 Cuts a circle with the selected radius. (Radius (R) = 3, 5, 10, 15, 20, 50, 100 mm)</p>  <p>R = 3 to 100</p>	<p>V-CUT straight lines Check the θ correction values for the work to be cut using the V-cut tool.</p>  <p>Required tools Units B to D: V-cut tool</p> <ul style="list-style-type: none"> • Available only when V45 and VAS are selected. • Mount the pen on unit A in advance.

Cutting Samples to Troubleshoot Issues

Before sample cutting, pen numbers must be assigned. (☞ P.4-12)

1 Set the drawing origin at the location where to perform sample cutting (☞ P.3-45).

2 On the local mode screen, press [TEST CUT].

- Press the [SEL] key to switch the function of the [FUNCTION] key.

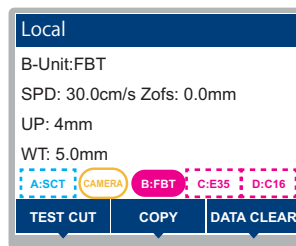

3 Press ▲ ▼ to select [Sample Cut].

4 Press the [ENTER] key.

5 Press ▲ ▼ to select a cutting pattern.

- Setting values: Crest, spade, square/triangle/circle, V-cut, V-cut straight line, circle R = 3 to R = 100

Hint! • In toggle mode, sample cut drawing is only possible in the front area.

6 Press the [ENTER] key to start drawing.

- To exit without performing sample cutting, press the [END/POWER] key.

Sample cutting results

If sample data can be cut normally but other data cannot
 ⇒ There is a problem with the host computer.

If both sample data and other data cannot be cut normally (when start/end points are not cut)
 ⇒ Set a higher value in [Adj-prs Offset] (☞ P.4-36) to apply stronger pressure when the cutter is down.

V-CUT straight line θ correction value selection

The results for the V-CUT straight line pattern can be used to check the θ correction value for the tool and work used.

However, this should be used after all of the tool adjustments (Center Adjust , Offset Adjust, Theta Angle Adjust) have been completed for the tool used.

- Hint!** • If problems arise with the cutting quality and accuracy for V-cutting, check to confirm that the tool has been correctly adjusted and the θ correction amount is appropriate.

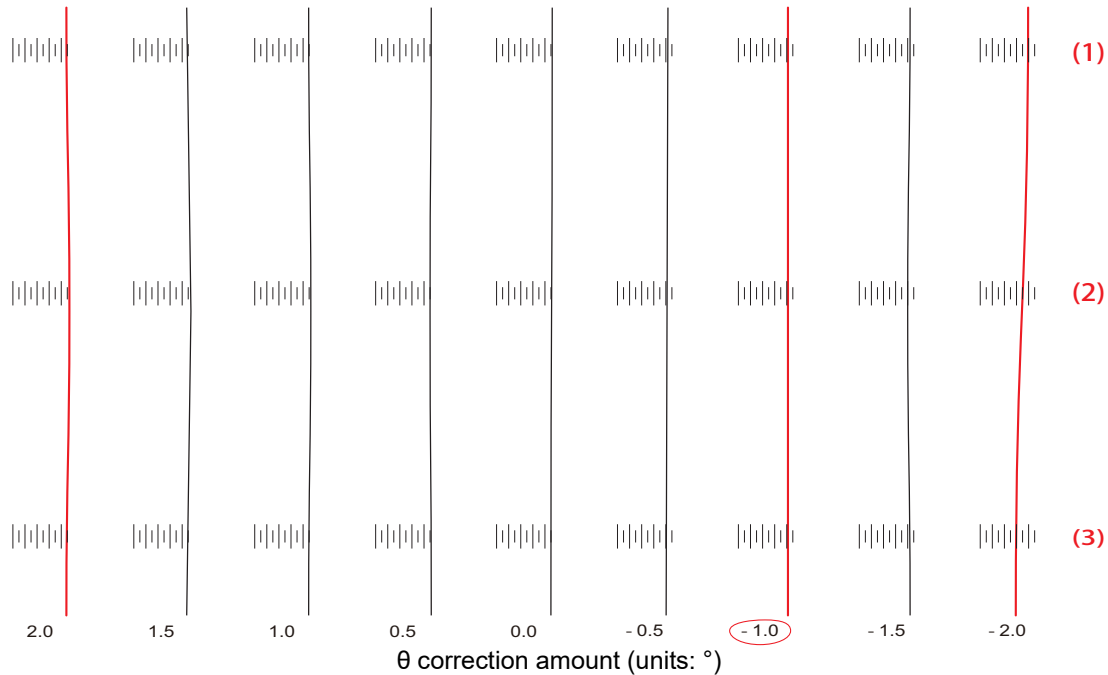

- The difference between the cut marks for V-cutting and the vertical lines drawn with the pen correspond to the θ correction amount at the position where (1), (2), and (3) are parallel to the scale at the same position or at the nearest position. Enter these values on the FineCut/Coat9 or CAMLINK2 conditions setting screen. (For details, refer to the FineCut/Coat9 Reference Guide or the CAMLINK2 Reference Guide.)
- If the cut marks are not parallel or are curved, check the following.
 - Is the V-cut tool loose?
 - Readjust the tool.

Chapter 9

Appendix



About this chapter

This chapter explains the specifications of the machine.

Specifications.....	9-2	Marker Pens Compatible with the CFX Series	9-31
Optional accessories.....	9-3	License Library (EPL5 StarterWare)	9-33
Accessories.....	9-8		
Supplies	9-21		

Specifications

Specifications		Model	CFX-2513	CFX-2531	CFX-2550
Active Working Space	X axis		1300 mm	3190 mm	5080 mm
	Y axis		2540 mm		
Work size that can be set	X axis		1890 mm	3780 mm	5670 mm
	Y axis		2570 mm		
Drive types			X/Y axis: AC servo Z/θ axis: DC servo		
Mountable units Unit	A		Standard unit (standard)		
	B		Tangential unit (optional)		
	C		Tangential unit (optional)		
	D		Tangential unit (optional)		
Maximum cuttable height			E12: 54 mm E35: 54 mm E60: 54 mm V45: 20 mm VAS: 20 mm FBT: 10 mm C16: 3 mm C26: 5 mm C60: 10 mm C6A:15mm		
Maximum work weight on table			50 kg/m ² (must be distributed)		
Method of securing works			Held by vacuum		
Commands			MGL-3C		
Receive buffer capacity			22 MB (16 MB when sorting is enabled)		
Interfaces			RS-232C / Ethernet		
Power supply specifications			200 to 240 V AC, 50/60 Hz, 12 A or less, single phase		
Power consumption			3000 W or less		
External dimensions			4050 mm × 2150 mm × 1500 mm	4050 mm × 4050 mm × 1500 mm	4050 mm × 5950 mm × 1500 mm
Weight of main unit			440 kg	660 kg	880 kg
Noise level	During standby		Max. 55 dB(A)		
	During operation		Max. 79 dB(A)		
Compliance with standards			VCCI-class A, FCC class A, CE markings, CB report (EN62368), UL62368-1, Machinery Directive, RoHS, REACH		
Operating environment	Permissible ambient temperature Relative humidity		5 to 35°C 35 to 75% RH, no condensation		
	Temp. range for guaranteed accuracy Relative humidity		20 to 25°C 35 to 65% RH, no condensation		
	Temp. gradient		±10°C/h or less (±50°F/h or less)		
Packing	Main unit		No stacking (when moving) May be stacked up to 2 units high in storage. (Must not be moved while stacked.) Must not be stacked with other products.		
	Extended table		May be stacked up to 2 units high in storage Must not be stacked with other products.		

Options

Part name	Part No.	Specifications
Computer interface cable (5 m)	RSC-32-05	For RS-232C connection
Additional table unit for CFX	OPT-C0248	
5.5 kw / 6.3 kw vacuum unit assy.	OPT-C0249	Single layer 200 V, 5.5 / 6.3 kw Sold separately: Filter element (SPC-0226)
Tangential Unit - TUT-15	OPT-C0250	
High-pressure tangential Unit - TUT-30	OPT-C0271	
Camera Unit - Camera	OPT-C0252	
X31 cableveyor assy.	OPT-C0253	Used for 2513 → 2531, 2550 → 2531
X50 cableveyor assy.	OPT-C0254	Used for 2513 → 2550, 2531 → 2550
X13 cableveyor assy.	OPT-C0270	Used for 2531 → 2513, 2550 → 2513
Universal pen adapter	OPT-C0259	Compatible with 9 pens
Flat Blade Tool - FBT	OPT-C0256	
Electric Reciprocating Tool: Amplitude 1.2 mm - E12	OPT-C0272	
Electric Reciprocating Tool: Amplitude 3.5 mm - E35	OPT-C0257	
Electric Reciprocating Tool: Amplitude 6.0 mm - E60	OPT-C0258	
Creasing Tool: Diameter 16 mm - C16	OPT-C0261	
Creasing Tool: Diameter 26 mm - C26	OPT-C0262	
Creasing Tool: Diameter 60 mm - C60	OPT-C0263	
Creasing Tool: Diameter 110mm - C6A	OPT-01021	
V-Cut Tool: 45° - V45	OPT-C0264	
V-Cut Tool: Angle Selection Type - VAS	OPT-C0265	
V45 Tool TYPE-S	OPT-C0277	
VAS Tool TYPE-S	OPT-C0278	
5.5 kW/6.3 kW blower base (with filter/silencer)	OPT-C0266	5.5 / 6.3 kw (for overseas use) Sold separately: Filter element (SPC-0226)
Blade edge adjuster	OPT-C0066	
Blade edge adjuster MSP	OPT-C0240	
Vacuum unit control cable 5 m assy.	OPT-C0273	Used only with 2550
Foot switch 6 m assy.	OPT-C0275	Optional for 2513; included as standard accessories only for 2531 and 2550
Foot switch 10 m assy.	OPT-C0276	Included as a standard accessory only for 2550
Router unit	OPT-C0251	
R10 cable assy.	OPT-C0267	CFX-2513
R10 cable assy.	OPT-C0268	CFX-2531
R10 cable assy.	OPT-C0269	CFX-2550
Table control Box assy.	M028650	
7.5 kw / 8.6 kw vacuum unit 200V assy.	OPT-01035	
7.5 kw / 8.6 kw vacuum unit 400V assy.	OPT-01036	
Toggle Unit	OPT-01037	

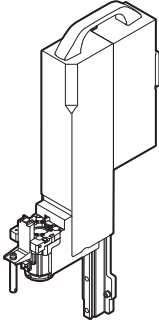
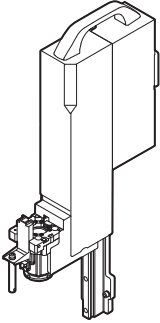
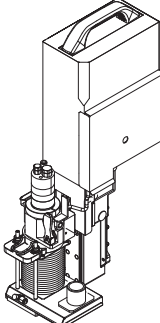

Optional accessories

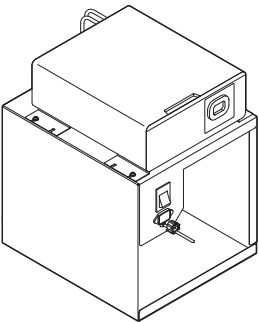
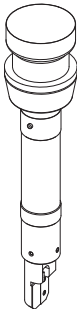
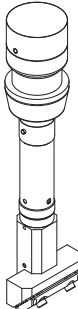
					
Part name	Low-pressure tangential Unit - TUT-15	Part name	High-pressure tangential Unit - TUT-30	Part name	Router unit
Part No.	OPT-C0250	Part No.	OPT-C0271	Part No.	OPT-C0251
Notes		Notes		Notes	

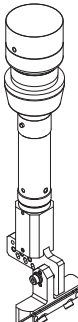
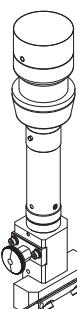
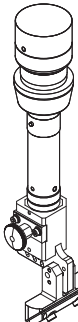

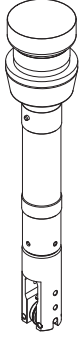
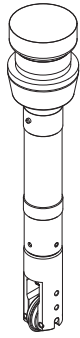
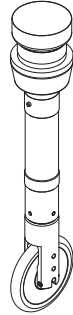
					
Part name	Table control Box assy.	Part name	Flat Blade Tool - FBT	Part name	V-Cut Tool: 45° - V45
Part No.	M028650	Part No.	OPT-C0256	Part No.	OPT-C0264
Notes		Notes		Notes	

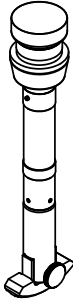
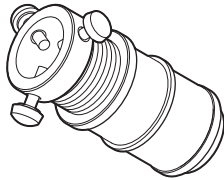
					
Part name	V-Cut Tool: Angle Selection Type - VAS	Part name	V45 Tool TYPE-S	Part name	VAS Tool TYPE-S
Part No.	OPT-C0265	Part No.	OPT-C0277	Part No.	OPT-C0278
Notes		Notes		Notes	

					
Part name	Creasing Tool: 16 mm dia. - C16	Part name	Creasing Tool: 26 mm dia. - C26	Part name	Creasing Tool: 60 mm dia. - C60
Part No.	OPT-C0261	Part No.	OPT-C0262	Part No.	OPT-C0263
Notes		Notes		Notes	

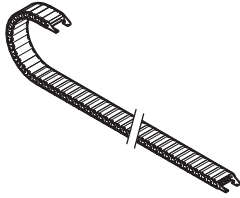
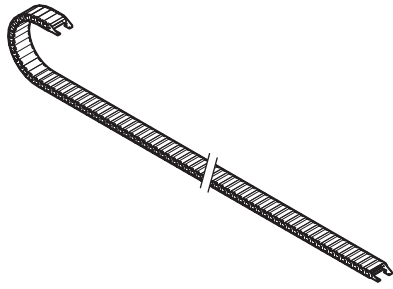
					
Part name	Creasing Tool: 110 mm dia- C6A	Part name	Universal pen adapter	Part name	Blade edge adjuster (for swivel cutter)
Part No.	OPT-01021	Part No.	OPT-C0259	Part No.	OPT-C0066
Notes		Notes		Notes	

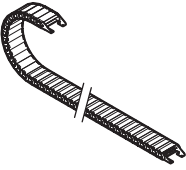
					
Part name	Blade edge adjuster MSP	Part name	X31 cableveyor assy.	Part name	X50 cableveyor assy.
Part No.	OPT-C0240	Part No.	OPT-C0253	Part No.	OPT-C0254
Notes		Notes		Notes	

					
Part name	X13 cableveyor assy.	Part name	Foot switch 6 m assy.	Part name	Foot switch 10 m assy.
Part No.	OPT-C0270	Part No.	OPT-C0275	Part No.	OPT-C0276
Notes		Notes		Notes	

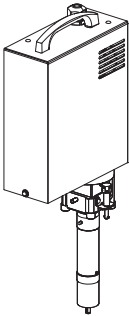
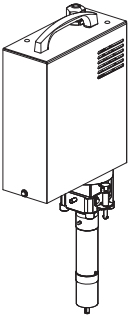
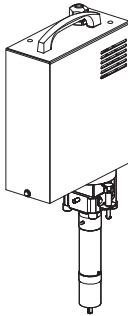
					
Part name	Electric Reciprocating Tool: Amplitude 1.2 mm - E12	Part name	Electric Reciprocating Tool: Amplitude 3.5 mm - E35	Part name	Electric Reciprocating Tool: Amplitude 6.0 mm - E60
Part No.	OPT-C0272	Part No.	OPT-C0257	Part No.	OPT-C0258
Notes		Notes		Notes	

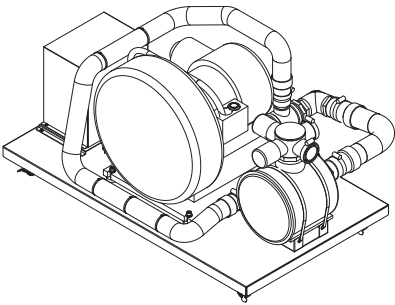
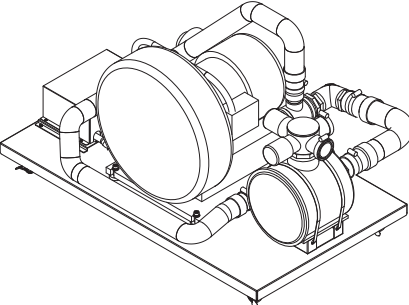
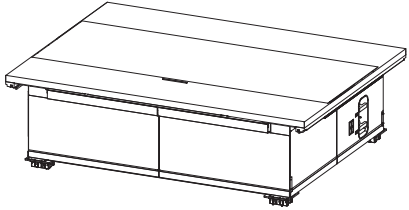
					
Part name	5.5 kW/6.3 kW vacuum unit assy.	Part name	5.5 kW/6.3 kW vacuum base (with filter/silencer)	Part name	Additional table unit for CFX
Part No.	OPT-C0249	Part No.	OPT-C0266	Part No.	OPT-C0248
Notes		Notes		Notes	



Part name	R10 cable assy.	Part name	R10 cable assy.	Part name	R10 cable assy.
Part No.	OPT-C0267	Part No.	OPT-C0268	Part No.	OPT-C0269
Notes	CFX-2513	Notes	CFX-2531	Notes	CFX-2550

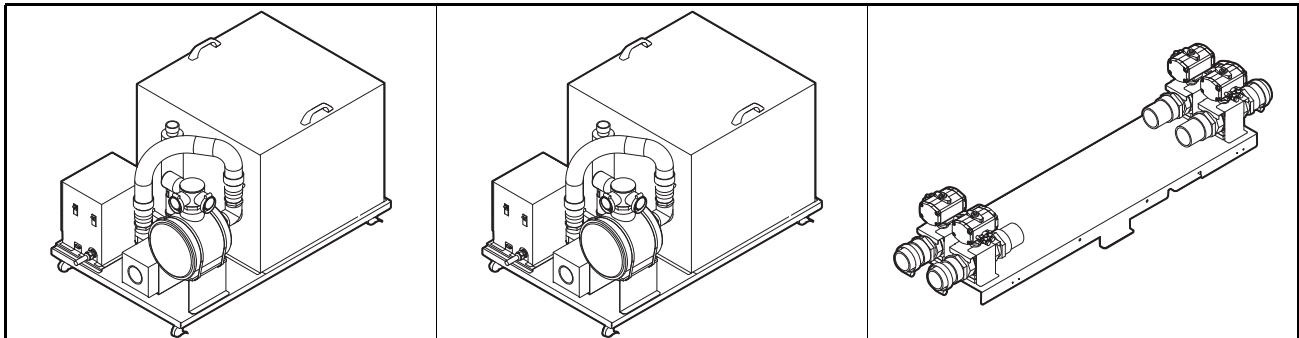

Part name	7.5 kw / 8.6 kw vacuum unit 200V assy.	Part name	7.5 kw / 8.6 kw vacuum unit 400V assy.	Part name	Toggle Unit
Part No.	OPT-01035	Part No.	OPT-01036	Part No.	OPT-01037
Notes		Notes		Notes	

OPT-C0248 Additional Table Unit for CFX

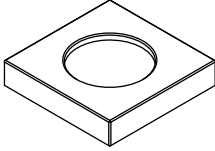
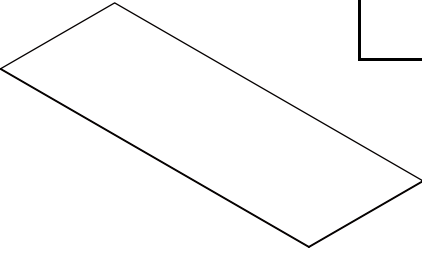
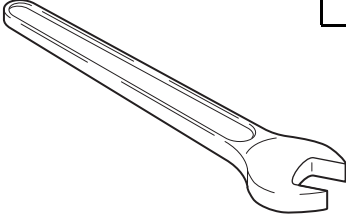
		Check			Check			Check
		<input type="checkbox"/>			<input type="checkbox"/>			
Part Name	Leg lay plate	Part Name	Hard mat B3.0 CFX	Part Name	Wrench			
Quantity	4	Quantity	2	Quantity	1			
Remarks	M028921	Remarks	SPC-0925	Remarks	19mm			

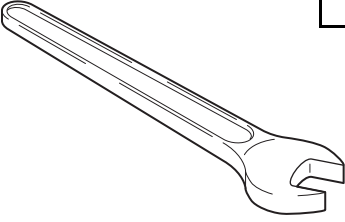
		Check			Check			Check
		<input type="checkbox"/>			<input type="checkbox"/>			
Part Name	Wrench	Part Name	-	Part Name	-			
Quantity	1	Quantity	-	Quantity	-			
Remarks	24mm	Remarks	-	Remarks	-			

OPT-C0250 / OPT-C0271 Tangential Unit TUT-15

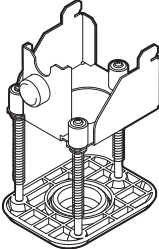
		Check		Check		Check	
Part Name	Media holder pressing unit S assy.	Part Name		Part Name		Part Name	
Quantity	1	Quantity		Quantity		Quantity	
Remarks	M028945	Remarks		Remarks		Remarks	

OPT-C0256 Flat Blade Tool - FBT

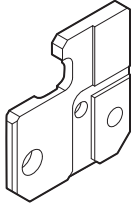
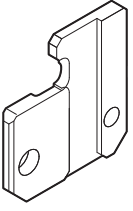
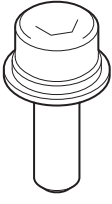
		Check <input type="checkbox"/>			Check <input type="checkbox"/>			Check <input type="checkbox"/>
Part Name	Cutter blade retainer T4	Part Name	Cutter blade retainer T6	Part Name	Screw			
Quantity	1	Quantity	1	Quantity	2			
Remarks	M215334	Remarks	M215335	Remarks	CS3x10SMW, black			

OPT-C0264 V-Cut Tool: 45° - V45

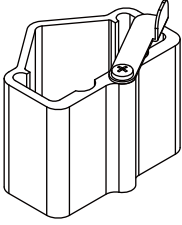
		Check		Check		Check
		<input type="checkbox"/>		<input type="checkbox"/>		<input type="checkbox"/>
Part Name	V-cut blade cap	Part Name		Part Name		–
Quantity	1	Quantity		Quantity		–
Remarks	M6070521	Remarks		Remarks		–

OPT-C0277 V-Cut Tool: 45° - V45 TYPE-S

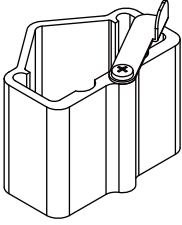
		Check		Check		Check
		<input type="checkbox"/>		<input type="checkbox"/>		<input type="checkbox"/>
Part Name	V45 tool exchange jig	Part Name		Part Name		–
Quantity	1	Quantity		Quantity		–
Remarks	M028935	Remarks		Remarks		–

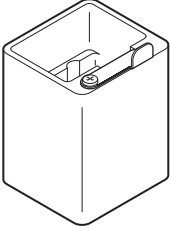

OPT-C0265 V-Cut Tool: Angle Selection Type - VAS

	Check <input type="checkbox"/>		Check <input type="checkbox"/>		Check <input type="checkbox"/>
Part Name	VAS blade cap	Part Name		Part Name	-
Quantity	1	Quantity		Quantity	-
Remarks	M607053	Remarks		Remarks	-

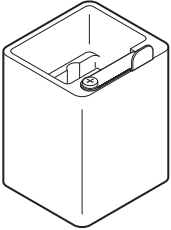
OPT-C0265 V-Cut Tool: Angle Selection Type - VAS TYPE-S

	Check <input type="checkbox"/>		Check <input type="checkbox"/>		Check <input type="checkbox"/>
Part Name	VAS tool exchange jig	Part Name		Part Name	-
Quantity	1	Quantity		Quantity	-
Remarks	M028934	Remarks		Remarks	-

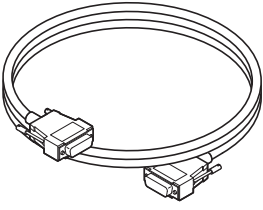
OPT-C0249 5.5 kw / 6.3 kw Vacuum Unit Assy.

					
<input type="checkbox"/> Check		<input type="checkbox"/> Check		<input type="checkbox"/> Check	
Part Name	Power cable	Part Name	Vacuum control cable 5 m assy.	Part Name	Blower hose
Quantity	1	Quantity	1	Quantity	2
Remarks		Remarks	OPT-C0273	Remarks	

					
<input type="checkbox"/> Check		<input type="checkbox"/> Check		<input type="checkbox"/> Check	
Part Name	Hose clamp	Part Name	–	Part Name	–
Quantity	4	Quantity	–	Quantity	–
Remarks		Remarks	–	Remarks	–

OPT-01035 7.5 kw / 8.6 kw Vacuum Unit 200 V Assy.

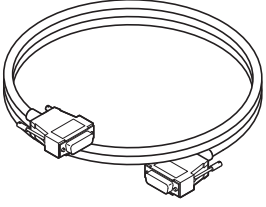
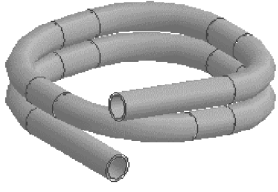
					
Check <input type="checkbox"/>		Check <input type="checkbox"/>		Check <input type="checkbox"/>	
Part Name	Cable gland	Part Name	Vacuum control cable 5 m assy.	Part Name	Blower hose
Quantity	1	Quantity	1	Quantity	2
Remarks		Remarks	OPT-C0273	Remarks	

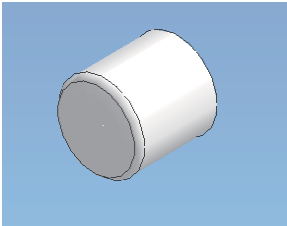

					
Check <input type="checkbox"/>		Check <input type="checkbox"/>		Check <input type="checkbox"/>	
Part Name	Hose clamp	Part Name	PVC Pipe Fitting Cap	Part Name	-
Quantity	4	Quantity	1	Quantity	-
Remarks		Remarks		Remarks	-

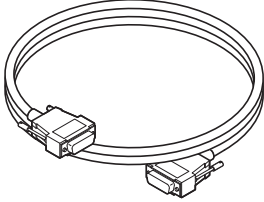
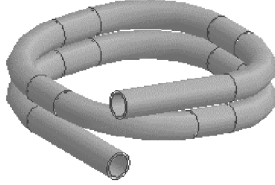

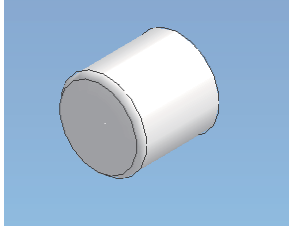
OPT-01036 7.5 kw / 8.6 kw Vacuum Unit 400 V Assy.

					
<input type="checkbox"/> Check		<input type="checkbox"/> Check		<input type="checkbox"/> Check	
Part Name	Cable gland	Part Name	Vacuum control cable 5 m assy.	Part Name	Blower hose
Quantity	1	Quantity	1	Quantity	2
Remarks		Remarks	OPT-C0273	Remarks	

					
<input type="checkbox"/> Check		<input type="checkbox"/> Check		<input type="checkbox"/> Check	
Part Name	Hose clamp	Part Name	PVC Pipe Fitting Cap	Part Name	–
Quantity	4	Quantity	1	Quantity	–
Remarks		Remarks		Remarks	–

OPT-01037 toggle unit Assy.

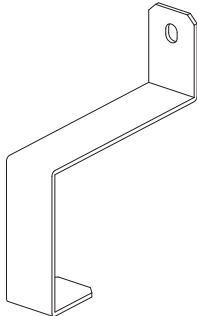
	Check <input type="checkbox"/>		Check <input type="checkbox"/>		Check <input type="checkbox"/>
Part Name	Polyurethane tube $\phi 10_2.0$ m	Part Name	Polyurethane tube $\phi 6_0.45$ m	Part Name	Polyurethane tube $\phi 6_3.7$ m
Quantity	1	Quantity	2	Quantity	4
Remarks		Remarks		Remarks	

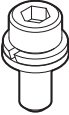
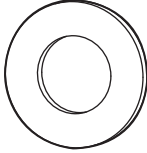

	Check <input type="checkbox"/>		Check <input type="checkbox"/>		Check <input type="checkbox"/>
Part Name	Hose clamp	Part Name	Relay box bracket	Part Name	T-shaped quick connector $\phi 10$
Quantity	8	Quantity	1	Quantity	1
Remarks		Remarks		Remarks	

	Check <input type="checkbox"/>		Check <input type="checkbox"/>		Check <input type="checkbox"/>
Part Name	Main unit connection harness Assy.	Part Name	Socket elbow	Part Name	Screw
Quantity	2	Quantity	4	Quantity	2
Remarks		Remarks		Remarks	CS4x10SMW

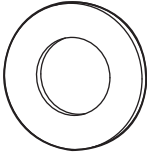
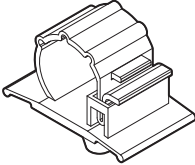
		Check			Check			Check
		<input type="checkbox"/>			<input type="checkbox"/>			
Part Name	Screw	Part Name	Screw	Part Name	Washer			
Quantity	3	Quantity	2	Quantity	1			
Remarks	CS5×10SMW	Remarks	CS6×15SMW	Remarks	W5 Trivalent black chromate Flat washer			

		Check			Check			Check
		<input type="checkbox"/>			<input type="checkbox"/>			
Part Name	Washer	Part Name	Cable clamp	Part Name	–			
Quantity	2	Quantity	13	Quantity	–			
Remarks	W6 Trivalent black chromate Flat washer	Remarks	CKS-13-H Cable clamp UL	Remarks	–			

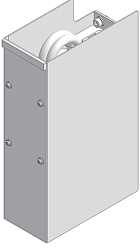

OPT-C0252 Camera Unit - CAMERA

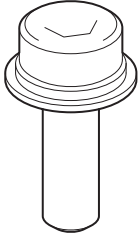
		Check <input type="checkbox"/>			Check <input type="checkbox"/>			Check <input type="checkbox"/>
Part Name	Camera unit main unit	Part Name	LAN cable	Part Name	Switching hub			
Quantity	1	Quantity	1	Quantity	1			
Remarks		Remarks		Remarks				

		Check <input type="checkbox"/>			Check <input type="checkbox"/>			Check <input type="checkbox"/>
Part Name	Power cable for hub	Part Name	Screw	Part Name	—			
Quantity	1	Quantity	4	Quantity	—			
Remarks		Remarks	CS5x12SMW	Remarks	—			

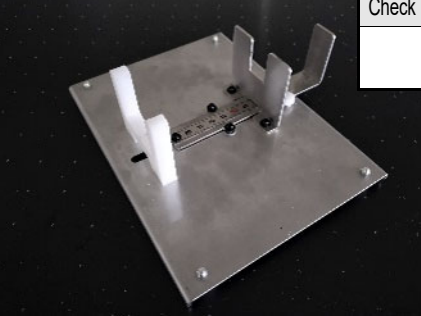
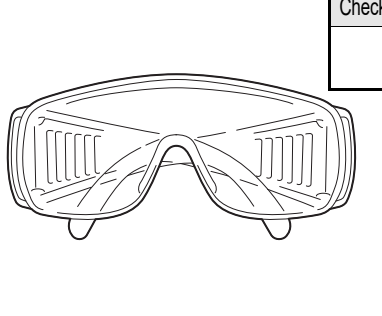
OPT-C0251 Router Unit: 1 kW - R10

		Check			Check			Check
Part Name	Wrench		Part Name	End mill replacement stand		Part Name	Safety glasses	
Quantity	2		Quantity	1		Quantity	1	
Remarks			Remarks	-		Remarks	VG-2010	

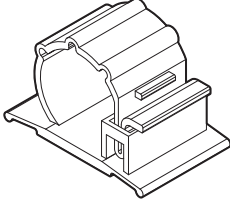
		Check			Check			Check
Part Name	Collet chuck		Part Name	Collet nut		Part Name	Clamp	
Quantity	1		Quantity	1		Quantity	CKS-20-L × 2, CKS-16-L × 26, CKS-13-L × 3	
Remarks			Remarks	-		Remarks		

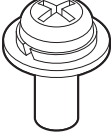
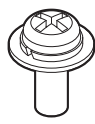
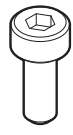
		Check			Check			Check
Part Name	Screw		Part Name	Screw		Part Name	Screw	
Quantity	14		Quantity	2		Quantity	2	
Remarks	P4x10SMW		Remarks	P3x8SMW		Remarks	CS3×8SMW	

		Check		Check		Check
		<input type="checkbox"/>		<input type="checkbox"/>		<input type="checkbox"/>
Part Name	Nylon clamp	Part Name		Part Name		
Quantity	10	Quantity		Quantity		
Remarks		Remarks		Remarks		

Purchase from a dealer or our service office.

Supplies List

★ : Included as a standard accessory



○ : Optional accessory/supply



Part name	Part no.	PEN OPT- C0259	FBT OPT- C0256	E12 OPT- C0272	E35 OPT- C0257	E60 OPT- C0258	V45 OPT- C0264 /OPT- C0277	VAS OPT- C0265 OPT- C0278	C16 OPT- C0261	C26 OPT- C0262	C60 OPT- C0263	CAM ERA OPT- C0252	Notes
Ball pen holder	SPA-0183	★											
Ballpoint pen refill	SPC-0726	○											
Holder for pressurized ballpoint pens	SPA-0288	○											
Pressurized ballpoint pen refill	SPC-0815	○											
Swivel cutter holder	SPA-0001	○											
Swivel cutter holder	SPA-0090	○											Recommended for CFX
Swivel cutter holder K	SPA-0329	○											
Carbide blade	SPB-0001	○											3 pc
Blade for low-pressure PVC sheet	SPB-0030	○											3 pc
Blade for small letters	SPB-0003	○											3 pc
Blade for rubber sheet S	SPB-0005	○											3 pc
Blade for reflective sheet	SPB-0006	○											2 pc
Blade for fluorescent sheet	SPB-0007	○											3 pc
Blade holder T4	M215334		○										Included with FBT
High-speed steel blade 30°	SPB-0043		○										40 pcs x 5 cases
High-speed steel blade 45°	SPB-0043		○										
Carbide blade 30°	SPB-0045		○										3 pc
Carbide blade DLC	SPB-0080		○										3 pc
Carbide blade 45°	SPB-0093		○										3 pc
Titanium-coated blade 30°	SPB-0047		○										1 pc
Titanium-coated blade 30°	SPB-0050		○										1 pc x 3 sets
Cutter blade retainer T6	M215335		○										Included with FBT
Carbide design blade 30°	SPB-0051		○										3 pcs
Joint sheet blade	SPB-0063		○										3 pcs
Reciprocating cutter holder S06	SPA-0343				○	○							
Carbide blade 2°	SPB-0064				○	○							5 pcs
Carbide blade 7×15	SPB-0075			○	○	○							For rubber up to 15 mm
Reciprocating cutter holder M06	SPA-0344				○	○							For CFL
20 mm blade	SPB-0055				○	○							10 pcs
Carbide blade 17°	SPB-0065			○	○	○							5 pcs
Carbide blade 17° DLC	SPB-0083			○	○	○							5 pcs
Reciprocating cutter holder L06	SPA-0345				○	—							
Carbide blade 25×5	SPB-0077				○	—							5 pcs
Carbide blade 25×5 DLC	SPB-0078				○	—							5 pcs
Carbide blade 25×5 F DLC	SPB-0079				○	—							5 pcs

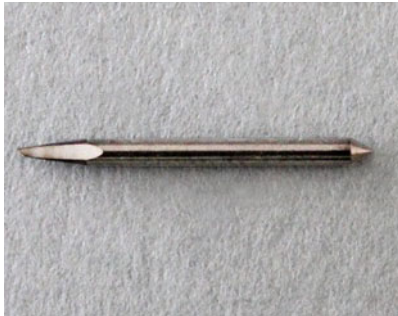

Part name	Part no.	PEN	FBT	E12	E35	E60	V45	VAS	C16	C26	C60	C6A	R10	CAME	Other	Notes
		OPT-C0259	OPT-C0256	OPT-C0272	OPT-C0257	OPT-C0258	OPT-C0264 / OPT-C0277	OPT-C0265 / OPT-C0278	OPT-C0261	OPT-C0262	OPT-C0263	OPT-01021	OPT-C0251	RA OPT-C0252		
Reciprocating cutter holder S10	SPA-0346				○	○										
40 mm carbide blade for CFR	SPB-0056				○	○										5 pcs
Reciprocating cutter blade S10 Carbide 2° × 50 mm	SPB-0094				○	○										CFX only
Reciprocating cutter blade S10 Carbide 2° × 20 mm	SPB-0097				○											CFX only
Media holder unit S	SPA-0360				○	○										
Media holder unit L	SPA-0359				○	○										
V-Cut Tool 45°	OPT-C0264						○	-								
V-cut blade 45	SPB-0095						○	-								
V-Cut Tool: Angle Selection Type	OPT-C0265						-	○								
V-cut blade 45	SPB-0095						-	○								
Creasing Tool: 16 mm dia. - C16	OPT-C0261								○	-	-	-				For coated board / B / E flute
Creasing Tool: 26 mm dia. - C26	OPT-C0262								-	○	-	-				For Corrugated plastic / A flute
Creasing Tool: 60 mm dia. - C60	OPT-C0263								-	-	○	-				For AA/ BB flute
Creasing Tool: 110 mm dia. - C6A	OPT-01021								-	-	-	○				For AAA flute
Filter element	SPC-0240														○	For vacuum
Filter □ 90	SPC-0922														○	For units, etc.
Filter □ 60	SPC-0923														○	Around head
Felt mat 2513X	SPC-0924														○	
Felt mat for additional table	SPC-0925														○	
Work guide	SPA-0368														○	
Collet chuck	SPA-0369													○		Shank diameter 6 mm
End mill: 3 mm dia., 9 mm blade	SPA-0067													○		
End mill: 3 mm dia., 12 mm blade	SPA-0068													○		
End mill: 4 mm dia., 8 mm blade	SPA-0069													○		
End mill: 6 mm dia., 12 mm blade, 42 mm active length	SPA-0070													○		
End mill: 6 mm dia., 12 mm blade, 63 mm active length	SPA-0071													○		
End mill: 4 mm dia., 8 mm blade	SPA-0072													○		
End mill: 3 mm dia., 6 mm blade	SPA-0074													○		
End mill: 6 mm dia., 12 mm blade A	SPA-0103													○		
End mill: 6 mm dia., 22 mm blade A	SPA-0104													○		
End mill: 6 mm dia., 32 mm blade A	SPA-0105													○		
Milling Underlay	SP-01029													○		
Torque wrench for R10 spindle	SP-01007													○		
Mark tip10	SP-01012													○		

Supplies

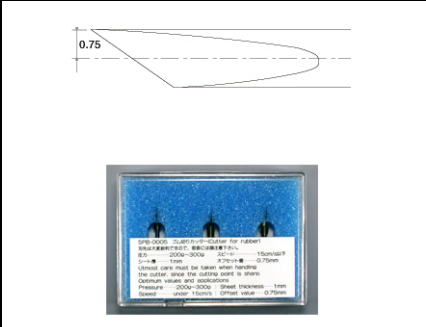

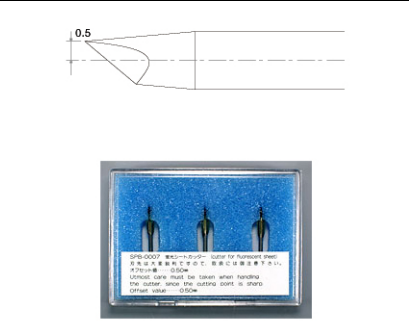
● Swivel cutter





		
Part name Cutter holder for swivel cutter	Part name Swivel cutter blade for PVC sheet	Part name Swivel cutter blade for small text
Part No. SPA-0090	Part No. SPB-0001	Part No. SPB-0003
Notes	Notes	Notes

		
Part name Swivel cutter blade for rubber sheet	Part name Swivel cutter blade for reflective sheet	Part name Swivel cutter blade for fluorescent sheet
Part No. SPB-0005	Part No. SPB-0006	Part No. SPB-0007
Notes	Notes	Notes

		
Part name Swivel cutter holder	Part name Swivel cutter holder	Part name Swivel cutter blade for PVC sheet, low pressure
Part No. SPA-0001	Part No. SPA-0329	Part No. SPB-0030
Notes	Notes	Notes

● FBT flat blade (tool)

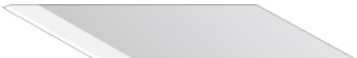



					
Part name	Titanium-coated blade 30°	Part name	Titanium-coated blade 30°	Part name	High-speed steel blade 30°
Part No.	SPB-0047	Part No.	SPB-0050	Part No.	SPB-0044
Notes	For T4	Notes	For T4	Notes	For T4



 					
Part name	Carbide blade 30°	Part name	High-speed steel blade 30°	Part name	Carbide blade 30° DLC
Part No.	SPB-0045	Part No.	SPB-0043	Part No.	SPB-0080
Notes	For T4	Notes	For T4	Notes	For T4

				 	
Part name	Carbide blade 45° (25L)	Part name	Carbide design blade 30°	Part name	Joint sheet carbide blade
Part No.	SPB-0093	Part No.	SPB-0051	Part No.	SPB-0063
Notes	For T4	Notes	For T6	Notes	For T6

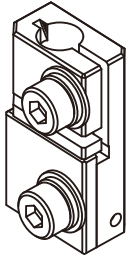

● Reciprocating cutter

 		 			
Part name	Carbide blade 2°	Part name	Carbide blade 7×15	Part name	Reciprocating cutter holder S06
Part No.	SPB-0064	Part No.	SPB-0075	Part No.	SPA-0343
Notes	For S06	Notes	For S06	Notes	For S06

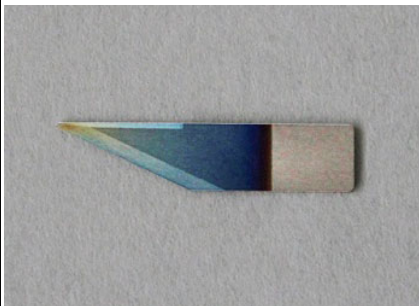
		 			
Part name	20 mm blade	Part name	Carbide blade 17°	Part name	Carbide blade 17° DLC
Part No.	SPB-0055	Part No.	SPB-0065	Part No.	SPB-0083
Notes	For M06	Notes	For M06	Notes	For M06

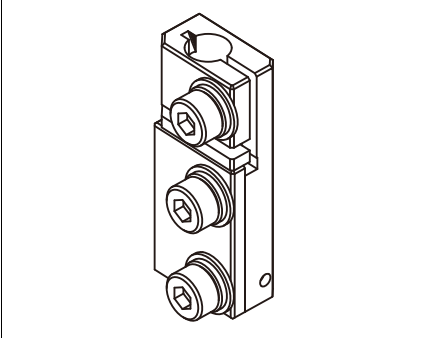
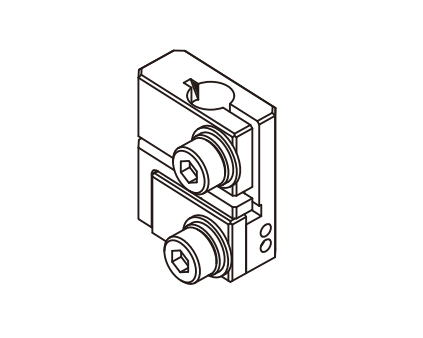

					
Part name	Reciprocating cutter holder M06	Part name	Carbide blade 25×5	Part name	Carbide blade 25×5 DLC
Part No.	SPA-0344	Part No.	SPB-0077	Part No.	SPB-0078
Notes	For M06	Notes	For L06	Notes	For L06

					
Part name	Carbide blade 25×5_F DLC	Part name	Reciprocating cutter holder L06	Part name	Reciprocating cutter holder S10
Part No.	SPB-0079	Part No.	SPA-0345	Part No.	SPA-0346
Notes	For L06	Notes	For L06	Notes	For S10

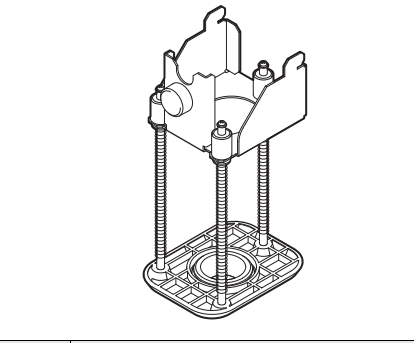
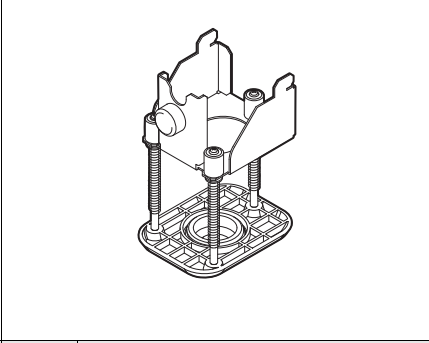
					
Part name	Reciprocating cutter blade S10 carbide 2° × 50 mm	Part name	Reciprocating cutter blade S10 carbide 2° × 20 mm	Part name	40 mm carbide blade for CRF (5 pcs)
Part No.	SPB-0094	Part No.	SPB-0097	Part No.	SPB-0056
Notes	For S10	Notes	For S10	Notes	For S10

					
Part name	Media holder unit L assy.	Part name	Media holder unit S assy.	Part name	
Part No.	SPA-0359	Part No.	SPA-0360	Part No.	
Notes		Notes		Notes	

● Creasing roller

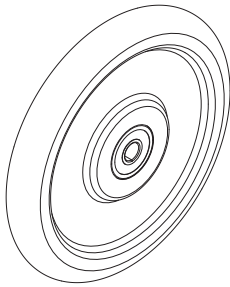

					
Part name	Creasing roller 16-CN	Part name	Creasing roller 16-DN	Part name	Creasing roller 26-T1
Part No.	SPB-0098	Part No.	SPB-0099	Part No.	SPB-0100
Notes	Crease 16	Notes	Crease 16	Notes	Crease 26

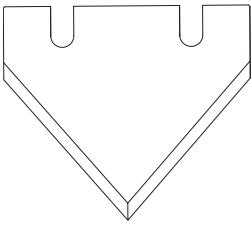

					
Part name	Creasing roller 26-CR	Part name	Creasing roller 60-UN	Part name	
Part No.	SPB-0101	Part No.	SPB-0102	Part No.	
Notes	Crease 26	Notes	Crease 60	Notes	



● V-cut

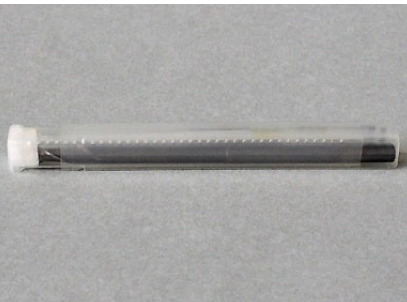

					
Part name	V-cut blade 45	Part name		Part name	
Part No.	SPB-0095	Part No.		Part No.	
Notes		Notes		Notes	

● R10

					
Part name	End mill for resin	Part name	End mill for aluminum composite sheet	Part name	End mill for 15 mm channels
Part No.	SPB-0067	Part No.	SPB-0068	Part No.	SPB-0069
Notes		Notes		Notes	

					
Part name	End mill for 30 mm channels	Part name	End mill for 50 mm channels	Part name	End mill for 5 mm acrylic
Part No.	SPB-0070	Part No.	SPB-0071	Part No.	SPB-0072
Notes		Notes		Notes	

					
Part name	End mill for 3 mm acrylic	Part name	End mill for 10 mm acrylic MDF	Part name	End mill for 20 mm acrylic MDF
Part No.	SPB-0074	Part No.	SPB-0103	Part No.	SPB-0104
Notes		Notes		Notes	

					
Part name	End mill for 30 mm MDF	Part name	Collet chuck	Part name	Torque wrench for R10 spindle
Part No.	SPB-0105	Part No.	SPA-0369 / SPA-0371	Part No.	SP-01007
Notes		Notes		Notes	

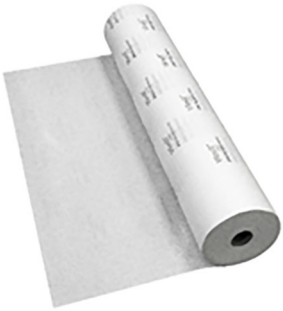
					
Part name	Milling Underlay	Part name		Part name	
Part No.	SP-01029	Part No.		Part No.	
Notes		Notes		Notes	

● CAMERA

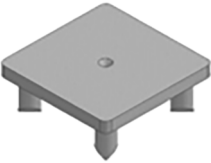
			
Part name	Mark tip 10	Part name	
Part No.	SP-01012	Part No.	
Notes		Notes	

Marker Pens Compatible with the CFX Series

Manufacturer	Part name	Ink type	Notes
Pentel	Felt-tip pen	Water-based	Popular water-based pens
Pentel	Fine cardboard marker	Oil-based	For corrugated cardboard
Pentel	Medium cardboard marker	Oil-based	For corrugated cardboard
Pilot	Fine oil-based marker	Oil-based dye	
Pilot	Ultra fine oil-based marker	Oil-based dye	
Pilot	Permanent Marker 100	Oil-based	Will not dry uncapped for a full day; economical
Pilot	Medium oil-based marker	Oil-based dye	
Sakura Color Products	My Name ultra fine	Oil-based	
Sakura Color Products	My Name	Oil-based	
Sakura Color Products	My Name fine	Oil-based	
Zebra	Mckee Pro fine special purpose DX	Oil-based pigment	Can be used on uneven or wet surfaces, or on smooth surfaces such as craft tape.
Sailor Pen Co.	Crafty	Oil-based	Can also write on coated surfaces such as craft tape. Not repelled by coatings; permanent, quick-drying, and durable.

Mimaki printer firmware

Copyright © 2020 Mimaki Engineering Co., Ltd. All rights reserved.

This product contains open source software listed in the following table.

Component	License
StarterWare for ARM® based TI Sitara Processors	BSD-TI

The following license terms and conditions apply to the open source software listed in the table above:

BSD-TI

Copyright © 2010 Texas Instruments Incorporated - <http://www.ti.com/>

Redistribution and use in source and binary forms, with or without modification, are permitted provided that the following conditions are met:

1. Redistributions of source code must retain the above copyright notice, this list of conditions, and the following disclaimer.
2. Redistributions in binary form must reproduce the above copyright notice, this list of conditions, and the following disclaimer in the documentation and/or other materials provided with the distribution.
3. Neither the name of Texas Instruments Incorporated nor the names of its contributors may be used to endorse or promote products derived from this software without specific prior written permission.

THIS SOFTWARE IS PROVIDED BY THE COPYRIGHT HOLDERS AND CONTRIBUTORS "AS IS" AND ANY EXPRESS OR IMPLIED WARRANTIES, INCLUDING, BUT NOT LIMITED TO, THE IMPLIED WARRANTIES OF MERCHANTABILITY AND FITNESS FOR A PARTICULAR PURPOSE ARE DISCLAIMED. IN NO EVENT SHALL THE COPYRIGHT OWNER OR CONTRIBUTORS BE LIABLE FOR ANY DIRECT, INDIRECT, INCIDENTAL, SPECIAL, EXEMPLARY, OR CONSEQUENTIAL DAMAGES (INCLUDING, BUT NOT LIMITED TO, PROCUREMENT OF SUBSTITUTE GOODS OR SERVICES; LOSS OF USE, DATA, OR PROFITS; OR BUSINESS INTERRUPTION) HOWEVER CAUSED AND ON ANY THEORY OF LIABILITY, WHETHER IN CONTRACT, STRICT LIABILITY, OR TORT (INCLUDING NEGLIGENCE OR OTHERWISE) ARISING IN ANY WAY OUT OF THE USE OF THIS SOFTWARE, EVEN IF ADVISED OF THE POSSIBILITY OF SUCH DAMAGE.

<hr/>	
Numerics	
<hr/>	
2-point Axis Correction	4-5
<hr/>	
A	
<hr/>	
About This Operation Manual	ix
Adjuster foot	1-6
Air tube connector	1-9
Automatic Head Retraction	1-22
Automatic mark detection	5-12
<hr/>	
B	
<hr/>	
Basic Operation Workflow	3-2
<hr/>	
C	
<hr/>	
Cable Connections	1-14
Connecting the Power Cable	1-14
Camera Adjustment	5-13
Caution	vi, x
Changing Cutting Conditions	3-18
Checking for unprocessed data	3-51
Commands	4-2, 4-55
Connector for control/Connector for control	1-9
Connector for optional accessories	1-8
Copy	4-13
Corner mode	5-14
Correction point	4-5
Cut Mode	4-2
Cutter Blade Maintenance	7-2
Cutting Area Settings	4-6
Cutting Conditions	3-18
Cutting Edge Detection	3-14
Cutting panel	1-6
<hr/>	
D	
<hr/>	
DATA CLEAR	3-49
Detecting the Mark Origin	5-15
Drawing	3-47
Drawing Origin	3-45
Dummy Cut	4-16
<hr/>	
E	
<hr/>	
Effective Cutting Area	3-47
Electrical box/Electrical box	1-6
Emergency Stop	
Resetting an Emergency Stop	1-16
Using Emergency Stop	1-16
Emergency stop	1-16
Emergency switch	1-6
Errors]	8-5
Ethernet connector/Ethernet connector	1-8

Example of symbols	x
External I/O terminal block	1-8

<hr/>	
F	
<hr/>	
Firmware	4-55
Flat Follow-Up Function	4-28
Foot switch 1 port	1-8
Foot switch 2 port	1-8
Free arrangement mode	5-14

<hr/>	
I	
<hr/>	
Important	x
Installation precautions	vi, xiii
Interrupting Processing	3-48
Introduction	ix

<hr/>	
J	
<hr/>	
Jog Mode	4-4

<hr/>	
K	
<hr/>	
Key Buzzer	4-42

<hr/>	
L	
<hr/>	
Language	4-40
LED pointer	1-7
License Library	9-33

<hr/>	
M	
<hr/>	
Main power supply switch	1-8
Manual Cutting	4-8
Mark Offset	5-17
Model	4-55
Moving the Head	3-4
Moving the Machine	1-5

<hr/>	
O	
<hr/>	
OH:Response Value	4-45
Operating Panel	1-10
Overcutting	4-37

<hr/>	
P	
<hr/>	
Part Names and Functions	1-6
Power inlet	1-8
Power supply connector	1-9
Power switch/Power switch	1-9
Preparing the Cutting Panel	1-18
Priority	4-44

R

Register Marks	
Blurry or Smudged Marks	5-9
Color	5-9
Continuous Cutting	5-19
No-Drawing Areas	5-6
Precautions on Mark Detection	5-10
Precautions When Preparing Data with Register Marks	5-2
Setting List	5-10
Setting Mark Detection Operation	5-10
Size	5-2
Supported Arrangements	5-4
Remote Control	4-3
Remote key interlocking	4-2
Restoring Default Settings	4-51
Resuming Processing	3-48
Routine Maintenance	7-2
Cleaning the Vacuum Filter	7-5
Cleaning with Auxiliary Air	7-9
Covers	7-2
Cutting Panel Surface	7-2
Dust-Collector Hose Maintenance	7-8
Electric reciprocating tool (E12, E35, E60)	7-4
Reciprocating tool	7-3
Units	7-3
RS-232C interface	1-8

S

Safety Precautions	x
Safety Sensor	3-50
Securing Works	
Securing Works with Adhesive Tape	3-9
Securing Works with Vacuum	3-10
Selecting Tools	3-17
SERIAL No.	4-55
Setting Computer Connection Conditions	4-46
Setting Felt Mat Thickness	4-31
Setting the Display Language	4-40
Setting the Display Unit	4-41
Setting the network	4-48
Setting Underlay Thickness	3-6
Setting Work Thickness	3-9
Setup Copy	4-50
Setup Reset	4-51
Sorting	4-14
Specifications	9-2
Startup Mode	4-43
Station A	1-7
Station B	1-7
Station C	1-7
Station D	1-7
Status Messages	8-13
Stopping Processing	3-49
Stroke Setting	4-15
Suction area range selection valve	1-6

Symbols	x
---------	---

T

Teaching mode	5-16
Test Cut	
Checking Status Between Tools	3-42
Checking tool status	3-39
Thickness of works that can be set/cut	3-9
Tip	x
Toggle Cutting (Toggle Mode)	4-18
Tool Adjustment	3-22
Adjusting Cutters	3-22
Circle Θ Correction	3-36
Troubleshooting	8-3
Troubleshooting Scenarios	8-2
Turning the Power On	3-3
TV and radio interference	vi

U

Usage precautions	xii
-------------------	-----

V

Vacuum	1-23
--------	------

W

Warning	x
Warning Labels	xiv
Warning/Error Messages	8-5
Work guide	1-18

Y

Y-bar	1-6
-------	-----

CFX Series Operation Manual

April 2026

© Mimaki Engineering Co., Ltd.

2182-3 Shigeno-otsu, Tomi-shi, Nagano 389-0512 Japan

D203687-21-09042026

